

This manual contains operation and maintenance information for series DA/EDA 103, 253, 403, 633, 1003 and related specifications. For customer specific models, there are additional instructions on those data sheets. The pressure filters listed above are intended for the filtering of liquid media.

## 1. Safety instructions



**WARNING: Avoid injury. Read and understand this manual before operating the filter. FAILURE TO FOLLOW THIS WARNING COULD LEAD TO DEATH, SEVERE INJURY, OR PROPERTY DAMAGE.** Eaton does not assume liability for any damage that occurs to due misuse of equipment.



**WARNING: This filter is a pressure vessel designed to operate under specific pressure, temperature, and other engineering parameters.** Follow the operating conditions specified on each data sheet. Operating outside of these parameters can cause damage to important pressure holding parts and sealing. Pay special attention to excess pressure, temperature range, and operating fluid. The compatibility of filter components with the operating fluid should always be considered before operation. **USE OF INCOMPATIBLE MATERIALS COULD LEAD TO PRODUCT FAILURE, LEAKAGE, DEATH, SEVERE INJURY OR PROPERTY DAMAGE.**



**WARNING: Always wear safety goggles and gloves when working on the filter.** Under working conditions, the filter housing is pressurized. Do not try to loosen or remove any part of the filter or the filter housing during operation. The operating fluid could escape at high pressure and high temperatures. This does not apply to the offline vessel that is not under operation. **FAILURE TO FOLLOW THIS WARNING COULD LEAD TO DEATH, SEVERE INJURY, OR PROPERTY DAMAGE.**



**WARNING: Leaking operating fluid can cause injury and burns. Equipment should be shut down and isolated from energy sources and other equipment before any inspection or servicing to prevent risk of shock or process fluid leakage.** Do not open the filter housing until you make sure it is not pressurized. The filter surface may be hot and cause burns. When changing the filter, check the operating temperature before touching any surface during operation. If you come into contact with the operating fluid, please follow the safety instructions provided by the fluid manufacturer. **FAILURE TO FOLLOW THIS WARNING COULD LEAD TO DEATH, SEVERE INJURY, OR PROPERTY DAMAGE.**

To ensure proper fit and function, only use Eaton spare parts.

## 2. Installation

The filter is supplied and delivered ready to be installed. The mounting position of the filter is vertical. The filter has to be fitted with fastening screws in size and amount according to the corresponding fastening bore holes of the filter housings. The filter should be mounted to minimize tensile forces on the filter housing and change-over valve. The piping should be connected with flanges.

During installation ensure that:

- No dirt and no impurities of foreign fluids penetrate the filter.
- The connections for input and output are correctly attached to the pipe system.
- The pipe system is connected to the filter to minimize stress on the filter.
- Ensure the filter element is accessible for service and change out.

Clogging indicators should be installed according to the instructions on the unit specific data sheet and the instructions in this manual.

Fitting the counterflanges

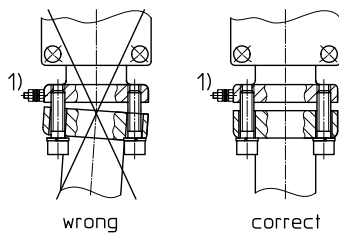

1) Connect the stand grounding tab to a suitable earth ground point.

When fastening the counter flanges, use the torque values in the table below. Ensure faces are parallel before fastening connections.

Type	DA/EDA 103	DA/EDA 253, 403	DA/EDA 633, 1003
Connection	1" (DN25)	2" (DN50)	3" (DN80)
Torque Nm [lbf.-ft. ]	10 ±2 [7 ±.08 ]	28 ±6 [21 ±.24 ]	71 ±15 [52 ±.56 ]

### 3. Commissioning

Ensure the filter installation is complete and the system is clean before commissioning. Follow these instructions to purge the filter before commissioning the system:

1. Before commissioning, ensure that the filter element and seals are clean and properly installed.
2. Place the switchgear lever in the middle position.
3. Fill both sides of the filter housing at the regular operating fluid flow.
4. Open the air bleed screws or connections. Connect tubes that lead to a drain pan (air-bleed connection information can be found on data sheet 1651).
5. Allow the operating fluid to drain (reduce volume flow from 10 to 50 l/min or 2.6 to 13.2 GPM until it is bubble-free and flows out of both air bleeding tubes.)
6. Shut off application flow.
7. Remove the air bleeding tubes and close the air-bleed bore holes or air-bleed connections.
8. Switch to the filter housing you would like to operate first by using the switch gear lever.
9. After finishing step 7, tighten the locking screws.

After following these instructions for commissioning, the serviced filter vessel is ready for operation.

#### **DA/EDA 103-1003 (illustration can slightly differ for different sizes)**

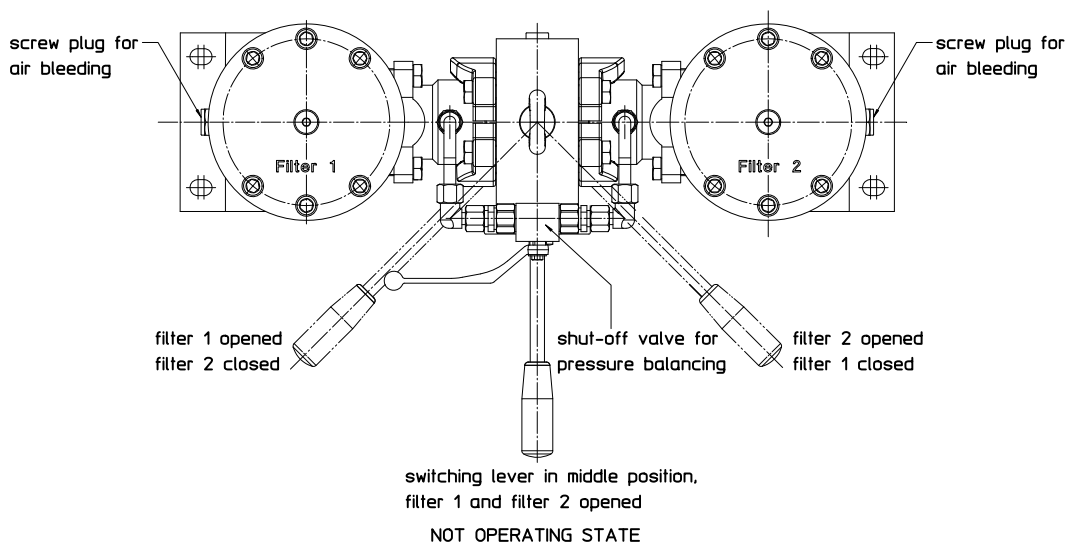



**WARNING:** Equipment should be shut down and isolated from energy sources and other equipment before any inspection or servicing to prevent risk of shock or process fluid leakage. Utilize proper application of PPE for the process conditions. **FAILURE TO FOLLOW THIS WARNING COULD LEAD TO DEATH, SEVERE INJURY, OR PROPERTY DAMAGE.**

#### **4. Change of elements**

Change the filter elements when the unit pressure differential on the clogging indicator reaches the maximum pressure differential specified for each unit on the data sheet. Do not allow the pressure differential to exceed 6 bar (87 psi) before replacing the elements. Follow these instructions to change the filter element without interrupting filter operation:

1. Open the pressure balance valve.
2. Move the switchgear lever from the operating vessel to the vessel you need to service. Switch gear instructions are located on a label on the filter vessel.
3. Close the pressure balance valve.
4. Open the air-bleed and the drain plug and connect with suitable hoses to a oil catch pan to drain the vessel (drain - connections acc. Document 1651).
5. Keep the air bleed and drain plug open until no more operating fluid drains out.
6. Loosen the screws of the lid on the vessel that needs servicing and remove the filter lid.
7. Remove the filter elements.
8. Clean the filter housing. Ensure that no dirt or cleaning fluid get into the clean side (center tube) of the filter element
9. Insert the clean filter element into the filter housing.
10. Place the filter lid back onto the filter housing and tighten the screw plugs. The screws need to be tightened in an X pattern. Recommended tightening torques listed in the table below:

Type	DA/EDA 103	DA/EDA 253, 403	DA/EDA 633, 1003
Screw	M10	M12	M16
Torque Nm [lbf.-ft. ]	45..50 [33..37 ]	65..70 [48..52 ]	125..130 [92..96 ]

11. Close the drain plugs.
12. Open the pressure balance valve until operating fluid flows out of the air bleed connection without bubbles.
13. Close the pressure balance valve and air bleed connection.
14. Retighten the screws on the lid after the vessel was pressurized for the first time.

After following these instructions to change the filter element, the serviced filter vessel is ready for operation.



**CAUTION:** Ensure the absolute cleanliness of the filter element is maintained during the entire servicing period. No dirt or impurities should penetrate the filter. The new elements should remain packaged until they are installed to prevent contamination. While removing an element from the a recently out of operation filter housing, make sure the element is fully discharged from any voltage caused by static charging during operation with certain fluids

Do not damage element seals during servicing. All sealing have to be checked on a regular basis to avoid leakage and potential development of an explosive atmosphere. Any damaged seals will need to be replaced. Any damaged seals have to be replaced. **FAILURE TO FOLLOW THIS WARNING COULD LEAD TO DEATH, SEVERE INJURY, OR PROPERTY DAMAGE.**

#### **5. Filter element cleaning**

Microglass (VG) or paper (P) filter media CANNOT be cleaned and need to be replaced when it reaches the dirt holding capacity. Wire mesh (G) filter media can be cleaned and used again. Follow the cleaning specification for Eaton filter elements, sheet no. 21070-4 and 39448-4 to clean wire mesh filter media.

## 6. Pressure difference measuring

If the filter assembly includes a clogging indicator, the indicator will measure the pressure difference across the filter element. The method of pressure reading varies depending on the type of indicator installed. It can be a visual, visual-electric or electronic reading. Additionally, the G ¼" (BSPP ¼") connections from the switchgear can be used for external pressure gauges. Measuring connections are recommended on data sheet 1650.

## 7. Special applications

This filter can be used in the special applications listed below. Please follow the instructions if you are operating the filter in these environments.

### Operation in explosive areas



**WARNING:** There are additional requirements for filters that are installed in explosive areas. Please follow the instructions on Eaton Document No. 41269. **FAILURE TO FOLLOW THIS WARNING COULD LEAD TO DEATH, SEVERE INJURY, OR PROPERTY DAMAGE.**

### Flushing operation for machines with a higher flow rate

If flushing the filter is required before operating the equipment, follow Eaton Document No. 51354.

## 8. Service

For product technical support and service, please contact the local Eaton support team. All locations and contact information are listed below.

Order spare parts and wearing parts according to the spare parts list on the filter data sheet.

**North America**  
44 Apple Street  
Tinton Falls, NJ 07724  
Toll Free: 800 656-3344  
(North America only)  
Tel: +1 732 212-4700

**China**  
No. 3, Lane 280,  
Linhong Road  
Changning District, 200335  
Shanghai, P.R. China  
Tel: +86 21 5200-0099

**Europe/Africa/Middle East**  
Auf der Heide 2  
53947 Nettersheim, Germany  
Tel: +49 2486 809-0

Friedensstraße 41  
68804 Altlufheim, Germany  
Tel: +49 6205 2094-0

An den Nahewiesen 24  
55450 Langenlonsheim, Germany  
Tel: +49 6704 204-0

**Singapore**  
4 Loyang Lane #04-01/02  
Singapore 508914  
Tel: +65 6825-1668

**Brazil**  
Rua Clark, 2061 - Macuco  
13279-400 - Valinhos, Brazil  
Tel: +55 11 3616-8400

For more information, please  
email us at [filtration@eaton.com](mailto:filtration@eaton.com)  
or visit [www.eaton.com/filtration](http://www.eaton.com/filtration)

© 2015 Eaton. All rights reserved. All trademarks and registered trademarks are the property of their respective owners. All information and recommendations appearing in this brochure concerning the use of products described herein are based on tests believed to be reliable. However, it is the user's responsibility to determine the suitability for his own use of such products. Since the actual use by others is beyond our control, no guarantee, expressed or implied, is made by Eaton as to the effects of such use or the results to be obtained. Eaton assumes no liability arising out of the use by others of such products. Nor is the information herein to be construed as absolutely complete, since additional information may be necessary or desirable when particular or exceptional conditions or circumstances exist or because of applicable laws or government regulations.