

Series AS 632

DN50-90

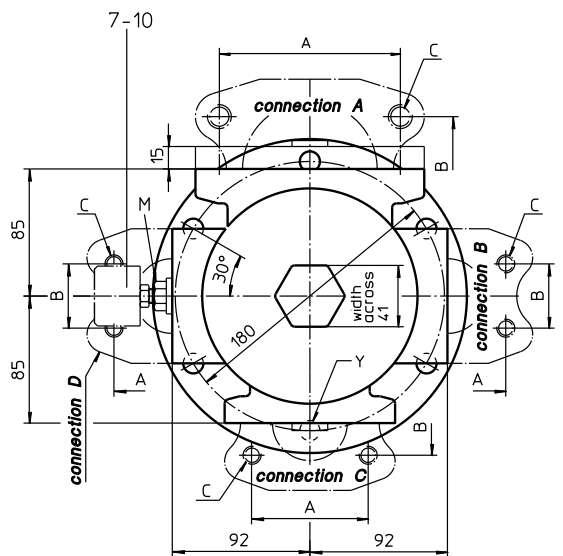
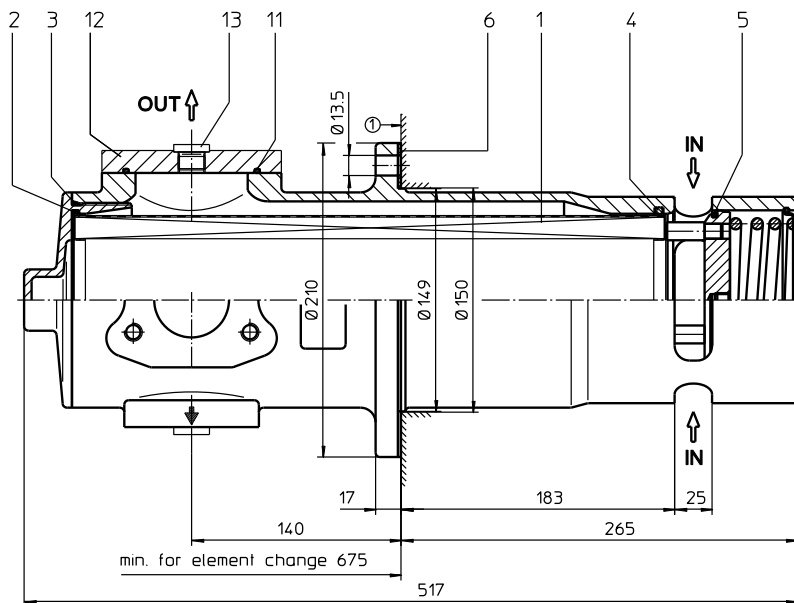

- mounting surface 1
- surface quality 3.2
▽
- flatness tolerance \square 0.2

Dimensions:

connection size	2"	2 1/2"	3"	3 1/2"
dimension A	77,8	89	106,4	120,7
dimension B	42,9	50,8	62	70
thread C	M12x18 deep	M12x18 deep	M16x22 deep	M16x22 deep

Weight approx.: 12 kg

Dimensions: mm

Suction Filter

Series AS 632

DN50-90

Description:

The AS filters can be installed horizontally or vertically in the tank and connected to the suction line. They are easy to maintain. The filter housing is made of high quality aluminum material.

The filter element consists of a star-shaped pleated filter material which is supported on the inside by a perforated core tube and is bonded to the end caps.

Eaton filter elements are known as stable elements which have excellent filtration capabilities and a high dirt retaining capacity, therefore having a long service life.

To change the filter element, the filter cover is unscrewed. When the filter cover is loosened, a plate valve closes the suction side of the filter and prevents dirty oil from flowing back into the tank or, if the filter is installed horizontally, the fluid from escaping from the tank. After the servicing respectively after changing the element the filter is again ready for operation.

Eaton filter can be used for petroleum-based fluids, HW emulsions, water glycols, most synthetic fluids and lubrication fluids. Consult factory for specific fluid applications.

Type index:

Complete filter: (ordering example)

AS. 632. 40G. -. B. P. -. FS. 11. -. O1

1	2	3	4	5	6	7	8	9	10	11
---	---	---	---	---	---	---	---	---	----	----

- 1 series:**
AS = Suction filter
- 2 nominal size:** 632
- 3 filter-material:**
40G stainless steel wire mesh
- 4 filter element collapse rating:**
- = not specified
- 5 filter element design:**
B = both sides open
- 6 sealing material:**
P = Nitrile (NBR)
V = Viton (FPM)
- 7 filter element specification:**
- = standard
VA = stainless steel
- 8 process connection:**
FS = SAE-flange connection 3000 PSI
- 9 no. of version:**

version	1	5	6	10	11	12	14	21
connection A type size	XY	XY	XY	FS A1	FS A1	FS A1	-	FS A
connection B type size	Y	M	M	FS 8	FS 9	-	FS 8	Y
connection C type size	FS 8	FS 9	FS 9	Y	Y	Y	FS 8	Y
connection D type size	FS 8	FS 9	-	Y	M	M	FS 8	FS 8

- type: FS = SAE-flange 3000 PSI
M = adapter M18x1,5-R1/8"
Y = drain M18x1,5
X = adapter SAE 3" – M18x1,5
- = no connection
- size: 8 = 2"
9 = 2 1/2"
A = 3"
A1 = 3 1/2"

- 10 filter housing specification:**
- = standard
- 11 clogging indicator**
- = without
O1 = visual, see sheet-no. 1616
E4.-0,25 = pressure switch, see sheet-no. 1616

To add an indicator to your filter, use the corresponding indicator data sheet to find the indicator details and add them to the filter assembly model code.

Filter element: (ordering example)

01AS. 631. 40G. -. B. -. -

1	2	3	4	5	6	7
---	---	---	---	---	---	---

- 1 series:**
01AS. = suction filter element according to company standard
- 2 nominal size:** 631
- 3 - 5 / 7** see type index-complete filter
- 6 seling material:**
- = without

Accessories:

- SAE-counter flanges, see sheet-no. 1652

Technical data:

operating temperature:	-10°C to +100°C
operating medium	mineral oil, other media on request
process connection:	SAE-flange 3000 PSI
housing material standard:	G-AISI10Mgwa DIN 1725 (3.2381.61)
sealing material:	Nitrile (NBR) or Viton (FPM), other materials on request
installation position:	optional
volume tank:	6,3 l

Classified under the Pressure Equipment Directive 2014/68/EU for mineral oil (fluid group 2), Article 4, Para. 3.
Classified under ATEX Directive 2014/34/EU according to specific application (see questionnaire sheet-no. 34279-4).

Pressure drop flow curves:

Filter calculation/sizing

The pressure drop of the assembly at a given flow rate Q is the sum of the housing Δp and the element Δp and is calculated as follows:

$$\Delta p_{assembly} = \Delta p_{housing} + \Delta p_{element}$$

$$\Delta p_{housing} = (\text{see } \Delta p = f(Q) \text{ - characteristics})$$

$$\Delta p_{element} (mbar) = Q \left(\frac{l}{min} \right) \times \frac{MSK}{10} \left(\frac{mbar}{l/min} \right) \times v \left(\frac{mm^2}{s} \right) \times \frac{p}{0,876} \left(\frac{kg}{dm^3} \right)$$

For ease of calculation our Filter Selection tool is available online at www.eaton.com/hydraulic-filter-evaluation

Material gradient coefficients (MSK) for filter elements

The material gradient coefficients in mbar/(l/min) apply to mineral oil (HLP) with a density of 0,876 kg/dm³ and a kinematic viscosity of 30 mm²/s (139 SUS). The pressure drop changes proportionally to the change in kinematic viscosity and density.

AS 632	40G
	0,0158

$\Delta p = f(Q)$ – characteristics according to ISO 3968

The pressure drop characteristics apply to mineral oil (HLP) with a density of 0,876 kg/dm³. The pressure drop changes proportionally to the density.

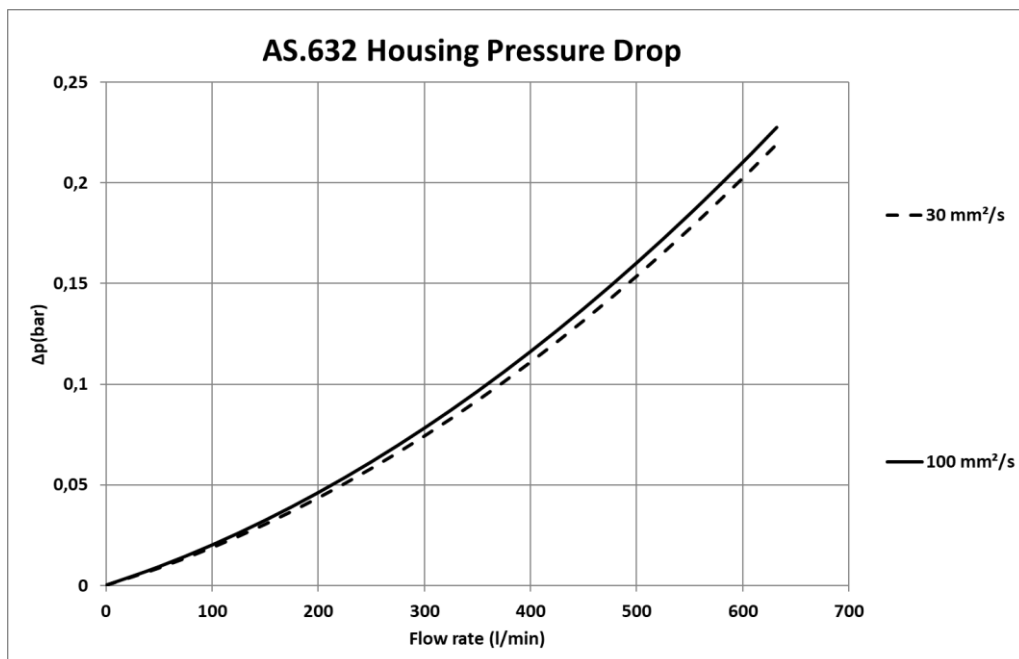

Symbols:

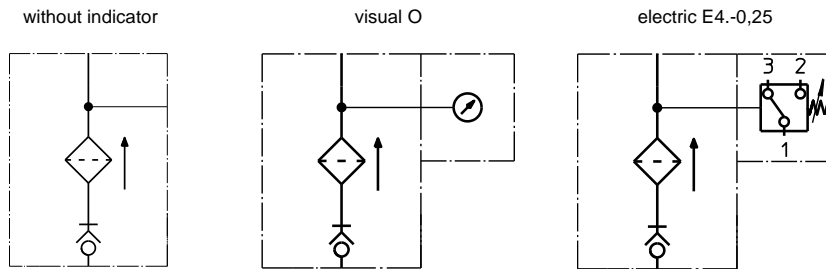

Spare parts:

item	qty.	designation	dimensions	article-no.	
1	1	filter element	01AS.631...		
2	1	O-ring	115 x 3	303963 (NBR)	307762 (FPM)
3	1	O-ring	125 x 3	306025 (NBR)	307358 (FPM)
4	1	O-ring	115 x 5	306640 (NBR)	310287 (FPM)
5	1	O-ring	104,37 x 3,53	304339 (NBR)	304390 (FPM)
6	1	gasket	2 thick	305160	
7	1	adapter M18x1,5 - R1/8"	30505-4	317114	
8	2	gasket	A18x24x1,5	305136	
9	1	clogging indicator, visual	O1	301722	
10	1	pressure switch, electric	E4.-0,25	301725	
11	1	O-ring	85,32 x 3,53	305590 (NBR)	306308 (FPM)
12	1	adapter SAE 3" - M18 x 1,5	30294-3	317048	
13	1	screw plug	M18x1,5	305193	

Test methods:

Filter elements are tested according to the following ISO standards:

ISO 2941	Verification of collapse/burst resistance
ISO 2942	Verification of fabrication integrity
ISO 2943	Verification of material compatibility with fluids
ISO 3723	Method for end load test
ISO 3724	Verification of flow fatigue characteristics
ISO 3968	Evaluation of pressure drop versus flow characteristics
ISO 16889	Multi-pass method for evaluating filtration performance

North America
44 Apple Street
Tinton Falls, NJ 07724
Toll Free: 800 656-3344
(North America only)
Tel: +1 732 212-4700

Greater China
No. 7, Lane 280,
Linhong Road
Changning District, 200335
Shanghai, P.R. China
Tel: +86 21 5200-0099

Europe/Africa/Middle East
Auf der Heide 2
53947 Nettersheim, Germany
Tel: +49 2486 809-0

Asia-Pacific
100G Pasir Panjang Road
#07-08 Interlocal Centre
Singapore 118523
Tel: +65 6825-1668

Friedensstraße 41
68804 Altlußheim, Germany
Tel: +49 6205 2094-0
An den Nahewiesen 24
55450 Langenlonsheim, Germany
Tel: +49 6704 204-0

**For more information, please
email us at filtration@eaton.com
or visit www.eaton.com/filtration**

© 2021 Eaton. All rights reserved. All trademarks and registered trademarks are the property of their respective owners. All information and recommendations appearing in this brochure concerning the use of products described herein are based on tests believed to be reliable. However, it is the user's responsibility to determine the suitability for his own use of such products. Since the actual use by others is beyond our control, no guarantee, expressed or implied, is made by Eaton as to the effects of such use or the results to be obtained. Eaton assumes no liability arising out of the use by others of such products. Nor is the information herein to be construed as absolutely complete, since additional information may be necessary or desirable when particular or exceptional conditions or circumstances exist or because of applicable laws or government regulations.