

Series HPZ 90 5075 PSI

Left hand installation

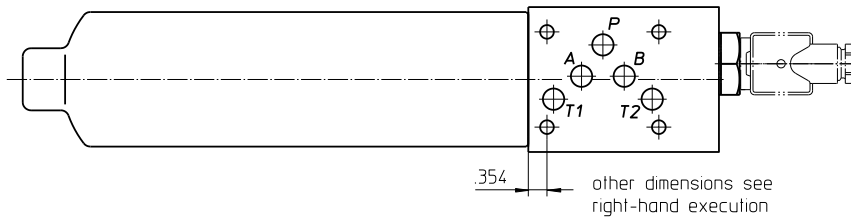

Right hand installation

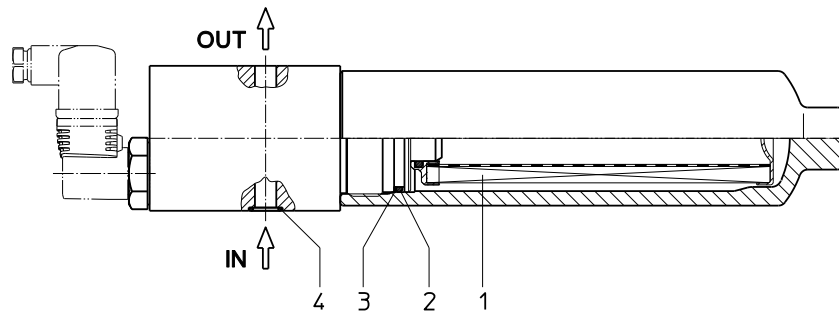
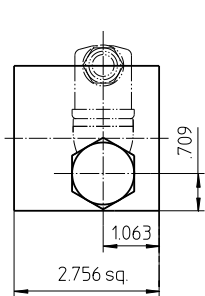
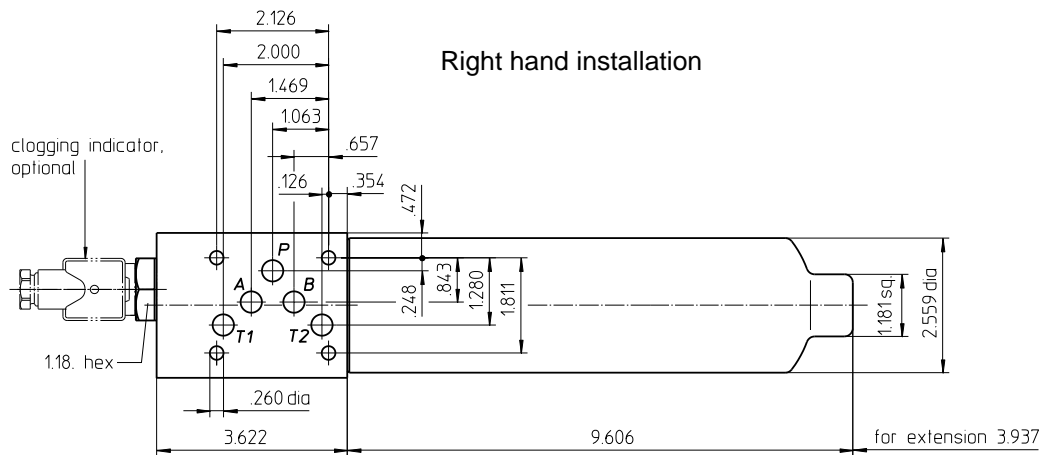

Weight: approx. 14.3 lbs.

Dimensions: inches

Designs and performance values are subject to change.



Powering Business Worldwide

Pressure Filter

Series HPZ 90

5075 PSI

Description:

The HPZ series filter is a valve protection filter according to DIN 24340-A10. These pressure filters are mounted between the valve and manifold to provide extra protection for critical valves. The HPZ filter can be mounted on either side of the valve for easy filter maintenance, depending on the filter configuration.

The filter element consists of star-shaped, pleated filter material, which is supported on the inside by a perforated core tube and is bonded to the end caps with a high-quality adhesive. The flow direction is from outside to inside. Filter elements are available down to 5 $\mu\text{m}_{(c)}$. Finer filtration is available upon request.

For cleaning the stainless steel mesh element or changing the filter element, remove the cover and take out the element. The mesh elements are not guaranteed to maintain 100% performance after cleaning.

Eaton filter elements are known for high intrinsic stability and an excellent filtration capability, a high dirt-retaining capacity and a long service life.

Eaton filter elements are available up to a pressure resistance of Δp 2320 PSI and a rupture strength of Δp 3625 PSI.

Eaton filter can be used for petroleum-based fluids, HW emulsions, water glycols, most synthetic fluids and lubrication fluids. Consult factory for specific fluid applications.

1. Type index:

1.1. Complete filter: (ordering example)

HPZ. 90. 10VG. HR. E. P. -. Z. 2. -. R. AE

1	2	3	4	5	6	7	8	9	10	11	12
---	---	---	---	---	---	---	---	---	----	----	----

- 1 series:**
HPZ = pressure filter for sandwich stacking
- 2 nominal size:** 90
- 3 filter-material and filter-fineness:**
80G, 40G, 25G, 10G stainless steel wire mesh
25VG, 16VG, 10VG, 6VG, 3VG microglass
- 4 filter element collapse rating:**
30 = Δp 435 PSI
HR = Δp 2320 PSI (rupture strength Δp 3625 PSI)
- 5 filter element design:**
E = single-end open
- 6 sealing material:**
P = Nitrile (NBR)
V = Viton (FPM)
- 7 filter element specification:**
- = standard
VA = stainless steel
- 8 process connection:**
Z = sandwich stacking according to DIN 24340, T2
- 9 process connection size:**
2 = A10 according to DIN 24340, T2
- 10 filter housing specification:**
- = standard
- 11 head design:**
R = right-hand installation
L = left-hand installation
- 12 clogging indicator or clogging sensor:**
- = without
AOR = visual, see sheet-no. 1606
AOC = visual, see sheet-no. 1606
AE = visual-electric, see sheet-no. 1615
VS5 = electronic, see sheet-no. 1619

To add an indicator to your filter, use the corresponding indicator data sheet to find the indicator details and add them to the filter assembly model code.

1.2. Filter element: (ordering example)

01E. 90 10VG. HR. E. P. -

1	2	3	4	5	6	7
---	---	---	---	---	---	---

- 1 series:**
01E. = filter element according to company standard
- 2 nominal size:** 90
- 3 - 7** see type index-complete filter

Technical data:

operating temperature:	+14°F to +212°F
operating medium	mineral oil, other media on request
max. operating pressure:	5075 PSI
test pressure:	7257 PSI
process connection:	(master gauge for holes) DIN 24340-A10
housing material:	EN-GJS-400-18-LT, C-steel (filter bowl)
sealing material:	Nitrile (NBR) or Viton (FPM), other materials on request
installation position:	vertical
volume tank:	0.10 Gal

Classified under the Pressure Equipment Directive 2014/68/EU for mineral oil (fluid group 2), Article 4, Para. 3.
 Classified under ATEX Directive 2014/34/EU according to specific application (see questionnaire sheet-no. 34279-4).

Pressure drop flow curves:

Filter calculation/sizing

The pressure drop of the assembly at a given flow rate Q is the sum of the housing Δp and the element Δp and is calculated as follows:

$$\Delta p_{assembly} = \Delta p_{housing} + \Delta p_{element}$$

$$\Delta p_{housing} = (\text{see } \Delta p = f(Q) \text{ - characteristics})$$

$$\Delta p_{element} (PSI) = Q (GPM) \times \frac{MSK}{1000} \left(\frac{PSI}{GPM} \right) \times \nu (SUS) \times \frac{\rho}{0.876} \left(\frac{kg}{dm^3} \right)$$

For ease of calculation our Filter Selection tool is available online at www.eaton.com/hydraulic-filter-evaluation

Material gradient coefficients (MSK) for filter elements

The material gradient coefficients in psi/gpm apply to mineral oil (HLP) with a density of 0.876 kg/dm³ and a kinematic viscosity of 139 SUS (30 mm²/s). The pressure drop changes proportionally to the change in kinematic viscosity and density.

HPZ	VG					G		
	3VG	6VG	10VG	16VG	25VG	25G	40G	80G
90	4.059	2.818	1.804	1.550	1.059	0.1210	0.1130	0.0774

$\Delta p = f(Q)$ – characteristics according to ISO 3968

The pressure drop characteristics apply to mineral oil (HLP) with a density of 0.876 kg/dm³. The pressure drop changes proportionally to the density.

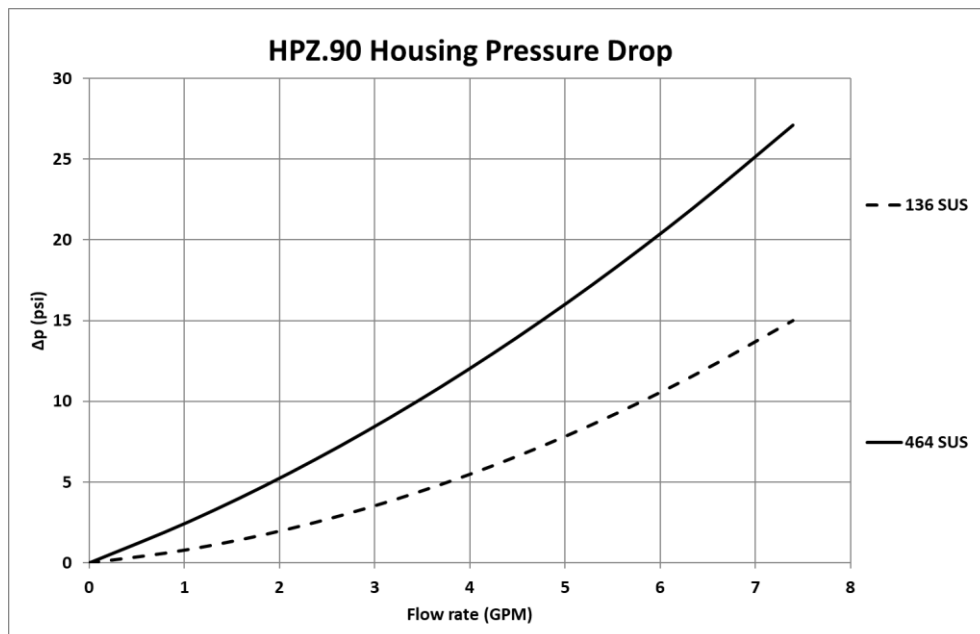

Symbols:

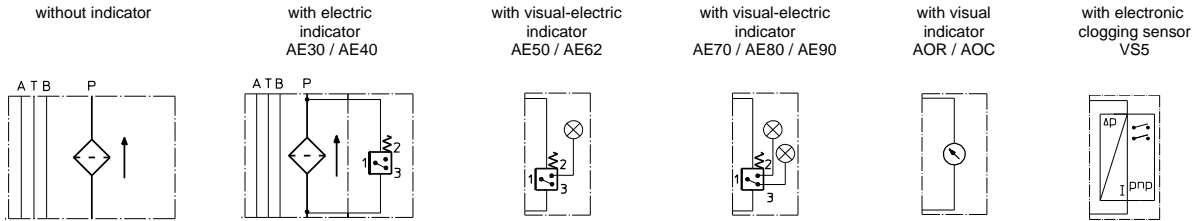

Spare parts:

item	qty.	designation	dimension	article-no.	
1	1	filter element	01E.90...		
2	1	O-ring	45 x 3	304991 (NBR)	304997 (FPM)
3	1	support ring	SRA 52 x 2,6 x 1	311013	
4	4	O-ring	12 x 2	311014 (NBR)	310271 (FPM)

Test methods:

Filter elements are tested according to the following ISO standards:

ISO 2941	Verification of collapse/burst resistance
ISO 2942	Verification of fabrication integrity
ISO 2943	Verification of material compatibility with fluids
ISO 3723	Method for end load test
ISO 3724	Verification of flow fatigue characteristics
ISO 3968	Evaluation of pressure drop versus flow characteristics
ISO 16889	Multi-pass method for evaluating filtration performance

North America
44 Apple Street
Tinton Falls, NJ 07724
Toll Free: 800 656-3344
(North America only)
Tel: +1 732 212-4700

Greater China
No. 7, Lane 280,
Linhong Road
Changning District, 200335
Shanghai, P.R. China
Tel: +86 21 5200-0099

Europe/Africa/Middle East
Auf der Heide 2
53947 Nettersheim, Germany
Tel: +49 2486 809-0

Asia-Pacific
100G Pasir Panjang Road
#07-08 Interlocal Centre
Singapore 118523
Tel: +65 6825-1668

Friedensstraße 41
68804 Altluisheim, Germany
Tel: +49 6205 2094-0

An den Nahewiesen 24
55450 Langenlonsheim, Germany
Tel: +49 6704 204-0

**For more information, please
email us at filtration@eaton.com
or visit www.eaton.com/filtration**

© 2021 Eaton. All rights reserved. All trademarks and registered trademarks are the property of their respective owners. All information and recommendations appearing in this brochure concerning the use of products described herein are based on tests believed to be reliable. However, it is the user's responsibility to determine the suitability for his own use of such products. Since the actual use by others is beyond our control, no guarantee, expressed or implied, is made by Eaton as to the effects of such use or the results to be obtained. Eaton assumes no liability arising out of the use by others of such products. Nor is the information herein to be construed as absolutely complete, since additional information may be necessary or desirable when particular or exceptional conditions or circumstances exist or because of applicable laws or government regulations.