

# Series HP3.60-150 6000 PSI

**Dimensions:**

type	HP3.60	HP3.90	HP3.150
connection	-8SAE	-12SAE	-16SAE
A	8.11	10.66	14.96
B	4.80	7.36	11.65
C	206	271	380
weight	7.7 lbs.	8.8 lbs.	11 lbs.
volume tank	.08 Gal.	.11 Gal.	.13 Gal.

- 1) Connection for the potential equalization, only for application in the explosive area.

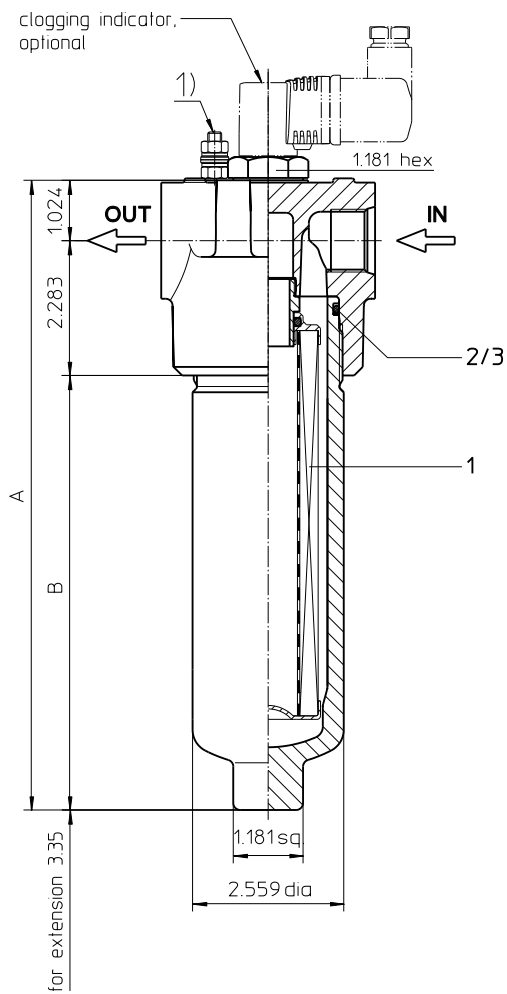
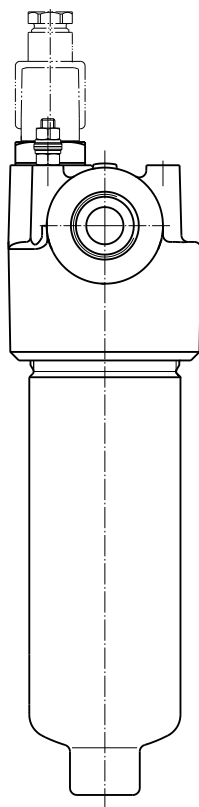
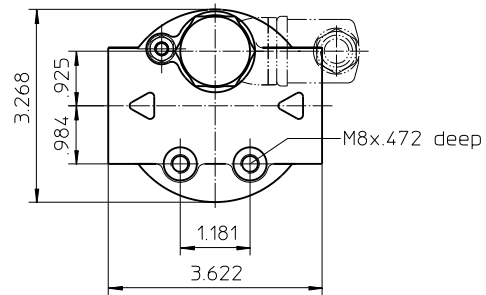

Dimensions: inches

Designs and performance values are subject to change.



Powering Business Worldwide

# Pressure Filter

## Series HP3.60-150

### 6000 PSI

#### Description:

Pressure filter series HP3.60-150 have a working pressure up to 6000 PSI. Pressure peaks can be absorbed with a sufficient safety margin. The HP3-filter is in-line mounted.

The filter element consists of star-shaped, pleated filter material, which is supported on the inside by a perforated core tube and is bonded to the end caps with a high-quality adhesive. The flow direction is from outside to inside. Filter elements are available down to 5  $\mu\text{m}_{(e)}$ . Finer filtration is available upon request.

For cleaning the stainless steel mesh element or changing the filter element, remove the cover and take out the element. The mesh elements are not guaranteed to maintain 100% performance after cleaning.

Eaton filter elements are known for high intrinsic stability and an excellent filtration capability, a high dirt-retaining capacity and a long service life.

Eaton filter can be used for petroleum-based fluids, HW emulsions, water glycols, most synthetic fluids and lubrication fluids. Consult factory for specific fluid applications.

Eaton filter elements are available up to a pressure resistance of  $\Delta p$  2320 PSI and a rupture strength of  $\Delta p$  3625 PSI.

The internal valves are integrated into the centering pivot for the filter element. After reaching the opening pressure the by-pass valve causes that an unfiltered partial flow passes the filter.

The reversing valve provides another level of protection for the filter element. The reverse flow will not be filtered.

#### 1. Type index:

##### 1.1. Complete filter: (ordering example)

**HP3. 90. 10VG. HR. E. P. -. UG. 4. -. -. AE**

1	2	3	4	5	6	7	8	9	10	11	12
---	---	---	---	---	---	---	---	---	----	----	----

- 1 series:**  
HP3 = pressure filter
- 2 nominal size:** 60, 90, 150
- 3 filter-material:**  
80G, 40G, 25G stainless steel wire mesh  
25VG, 16VG, 10VG, 6VG, 3VG microglass
- 4 filter element collapse rating:**  
30 =  $\Delta p$  435 PSI  
HR =  $\Delta p$  2320 PSI (rupture strength  $\Delta p$  3625 PSI)
- 5 filter element design:**  
E = single-end open
- 6 sealing material:**  
P = Nitrile (NBR)  
V = Viton (FPM)
- 7 filter element specification:**  
- = standard  
VA = stainless steel  
IS06 = for HFC applications, see sheet-no. 31601
- 8 process connection:**  
UG = thread
- 9 process connection size:**  
3 = -8 SAE  
4 = -12 SAE  
5 = -16 SAE
- 10 filter housing specification:**  
- = standard  
IS06 = for HFC applications, see sheet-no. 31605
- 11 internal valve:**  
- = without  
S1 = with by-pass valve  $\Delta p$  51 PSI  
S2 = with by-pass valve  $\Delta p$  102 PSI  
R = reversing valve,  $Q \leq 18.50$  GPM
- 12 clogging indicator or clogging sensor:**  
- = without  
AOR = visual, see sheet-no. 1606  
AOC = visual, see sheet-no. 1606  
AE = visual-electric, see sheet-no. 1615  
VS5 = electronic, see sheet-no. 1619

To add an indicator/sensor to your filter, use the corresponding indicator data sheet to find the indicator details and add them to the filter assembly model code.

##### 1.2. Filter element: (ordering example)

**01E. 90. 10VG. HR. E. P. -**

1	2	3	4	5	6	7
---	---	---	---	---	---	---

- 1 series:**  
01E. = filter element according to company standard
- 2 nominal size:** 60, 90, 150
- 3 - 7** see type index-complete filter

## Technical data:

operating temperature:	+14°F to +212°F
operating medium	mineral oil, other media on request
max. operating pressure:	6000 PSI
test pressure:	8700 PSI
process connection:	thread
housing material:	EN-GJS-400-18-LT, C-steel (filter bowl)
sealing material:	Nitrile (NBR) or Viton (FPM), other materials on request
installation position:	vertical

Classified under the Pressure Equipment Directive 2014/68/EU for mineral oil (fluid group 2), Article 4, Para. 3.  
 Classified under ATEX Directive 2014/34/EU according to specific application (see questionnaire sheet-no. 34279-4).

## Pressure drop flow curves:

### Filter calculation/sizing

The pressure drop of the assembly at a given flow rate Q is the sum of the housing  $\Delta p$  and the element  $\Delta p$  and is calculated as follows:

$$\Delta p_{assembly} = \Delta p_{housing} + \Delta p_{element}$$

$$\Delta p_{housing} = (\text{see } \Delta p = f(Q) \text{ - characteristics})$$

$$\Delta p_{element} (PSI) = Q (GPM) \times \frac{MSK}{1000} \left( \frac{PSI}{GPM} \right) \times \nu (SUS) \times \frac{\rho}{0.876} \left( \frac{kg}{dm^3} \right)$$

For ease of calculation our Filter Selection tool is available online at [www.eaton.com/hydraulic-filter-evaluation](http://www.eaton.com/hydraulic-filter-evaluation)

### Material gradient coefficients (MSK) for filter elements

The material gradient coefficients in psi/gpm apply to mineral oil (HLP) with a density of 0.876 kg/dm<sup>3</sup> and a kinematic viscosity of 139 SUS (30 mm<sup>2</sup>/s). The pressure drop changes proportionally to the change in kinematic viscosity and density.

HP3	VG					G		
	3VG	6VG	10VG	16VG	25VG	25G	40G	80G
60	6.748	4.685	2.999	2.577	1.760	0.2002	0.1868	0.1280
90	4.059	2.818	1.804	1.550	1.059	0.1210	0.1130	0.0774
150	2.422	1.681	1.076	0.925	0.632	0.0723	0.0675	0.0462

### $\Delta p = f(Q)$ – characteristics according to ISO 3968

The pressure drop characteristics apply to mineral oil (HLP) with a density of 0.876 kg/dm<sup>3</sup>. The pressure drop changes proportionally to the density.

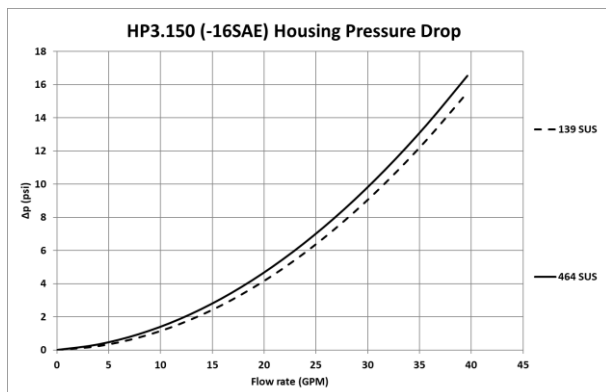
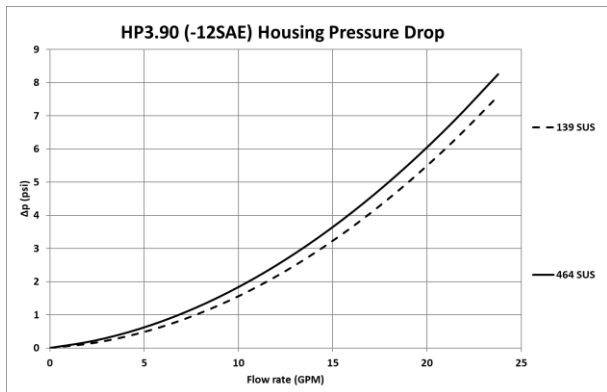
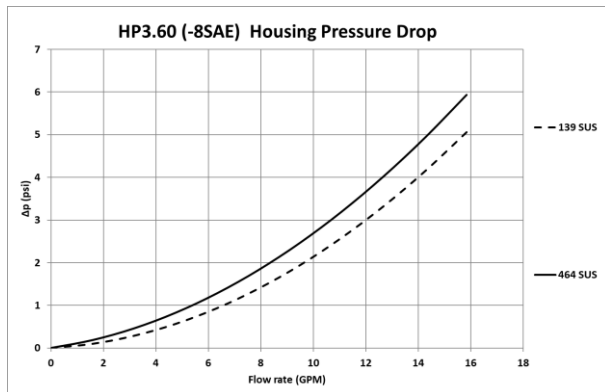

## Symbols:

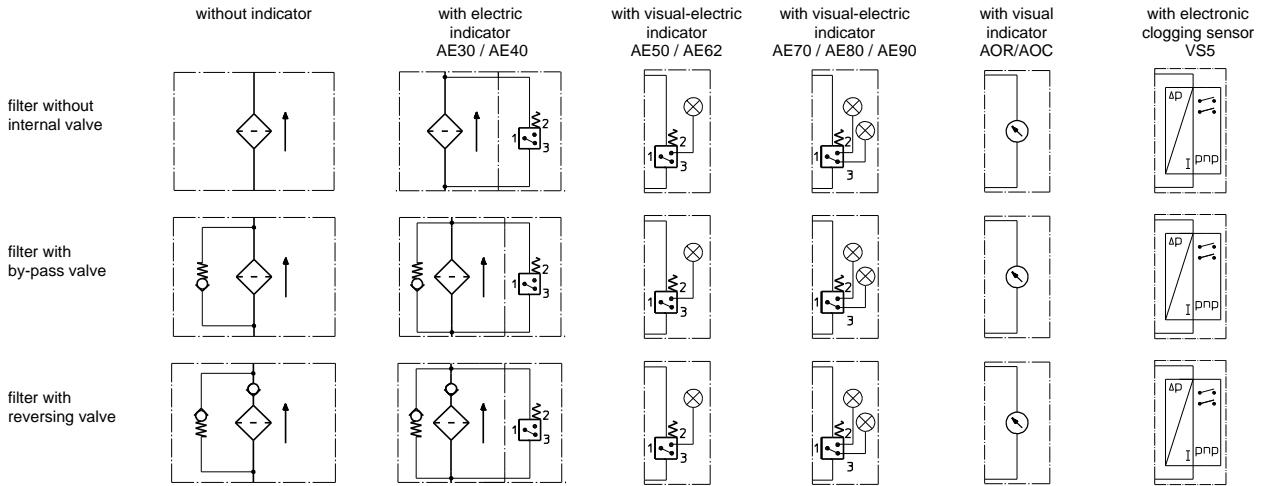

## Spare parts:

item	qty.	designation	dimension			article-no.	
			HP3.60	HP3.90	HP3.150		
1	1	filter element	01E.60...	01E.90...	01E.150...		
2	1	O-ring	54 x 3			304657 (NBR)	304720 (FPM)
3	1	support ring	61 x 2,6 x 1			304660	

## Test methods:

Filter elements are tested according to the following ISO standards:

ISO 2941	Verification of collapse/burst resistance
ISO 2942	Verification of fabrication integrity
ISO 2943	Verification of material compatibility with fluids
ISO 3723	Method for end load test
ISO 3724	Verification of flow fatigue characteristics
ISO 3968	Evaluation of pressure drop versus flow characteristics
ISO 16889	Multi-pass method for evaluating filtration performance

**North America**  
44 Apple Street  
Tinton Falls, NJ 07724  
Toll Free: 800 656-3344  
(North America only)  
Tel: +1 732 212-4700

**Greater China**  
No. 7, Lane 280,  
Linhong Road  
Changning District, 200335  
Shanghai, P.R. China  
Tel: +86 21 5200-0099

**Europe/Africa/Middle East**  
Auf der Heide 2  
53947 Nettersheim, Germany  
Tel: +49 2486 809-0

**Asia-Pacific**  
100G Pasir Panjang Road  
#07-08 Interlocal Centre  
Singapore 118523  
Tel: +65 6825-1668

Friedensstraße 41  
68804 Altlußheim, Germany  
Tel: +49 6205 2094-0

An den Nahewiesen 24  
55450 Langenlonsheim, Germany  
Tel: +49 6704 204-0

**EATON**  
Powering Business Worldwide

**For more information, please  
email us at [filtration@eaton.com](mailto:filtration@eaton.com)  
or visit [www.eaton.com/filtration](http://www.eaton.com/filtration)**

© 2021 Eaton. All rights reserved. All trademarks and registered trademarks are the property of their respective owners. All information and recommendations appearing in this brochure concerning the use of products described herein are based on tests believed to be reliable. However, it is the user's responsibility to determine the suitability for his own use of such products. Since the actual use by others is beyond our control, no guarantee, expressed or implied, is made by Eaton as to the effects of such use or the results to be obtained. Eaton assumes no liability arising out of the use by others of such products. Nor is the information herein to be construed as absolutely complete, since additional information may be necessary or desirable when particular or exceptional conditions or circumstances exist or because of applicable laws or government regulations.