

Series EHPF 170-450 4568 PSI

Dimensions:

type	EHPF 170	EHPF 240	EHPF 360	EHPF 450
connection	DN 28			
A	13.11	15.07	18.22	22.36
B	13.00	14.00	18.00	22.00
weight lbs.	48	53	57	66
volume tank	.18 Gal.	.23 Gal.	.31 Gal.	.42 Gal.

- 1) Connection for the potential equalization, only for application in the explosive area.

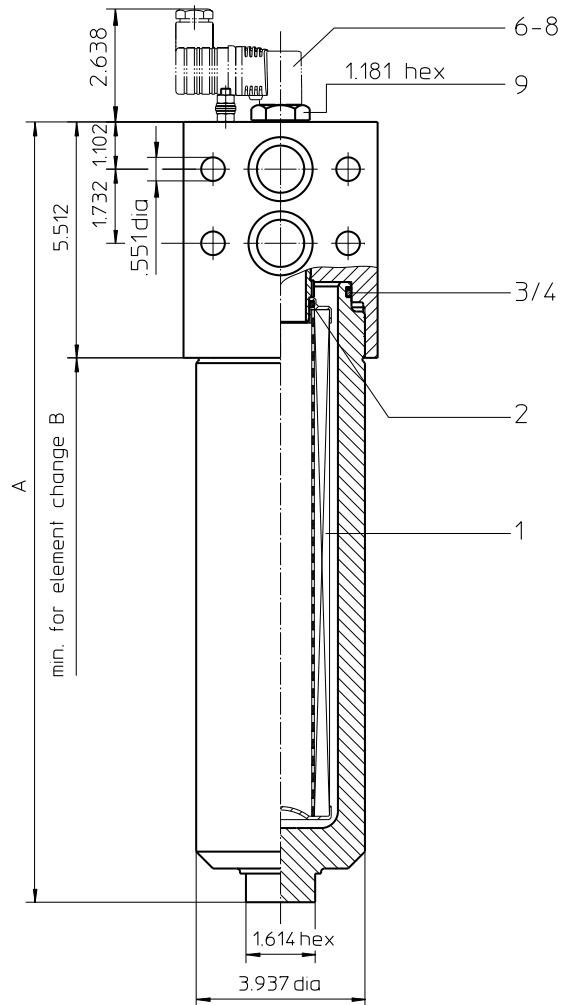
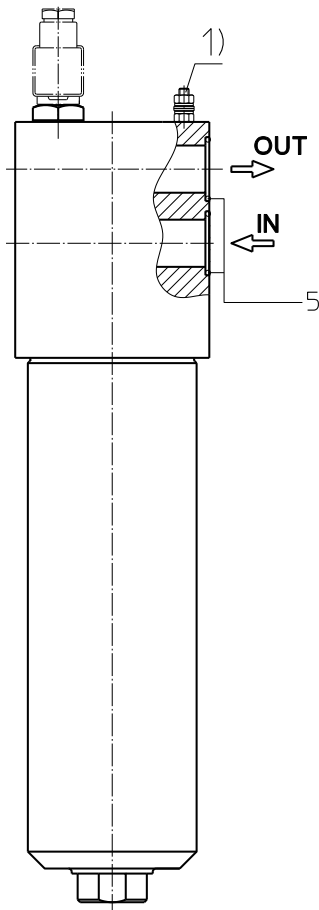
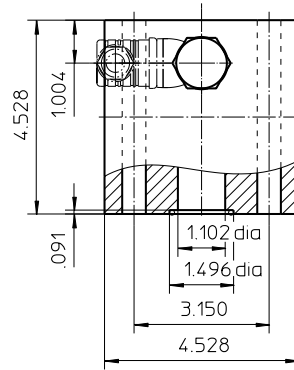

Pressure Filter

Series EHPF 170-450

4568 PSI

Description:

Stainless steel-pressure filter series EHPF 170-450 have a working pressure up to 4568 PSI. Pressure peaks can be absorbed with a sufficient safety margin. The EHPF-filters are flanged to the mounting-surface.

The filter element consists of star-shaped, pleated filter material, which is supported on the inside by a perforated core tube and is bonded to the end caps with a high-quality adhesive. The flow direction is from outside to inside. Filter elements are available down to 5 $\mu\text{m(c)}$.

Eaton filter elements are known for high intrinsic stability and an excellent filtration capability, a high dirt-retaining capacity and a long service life.

Eaton filter elements are available up to a pressure resistance of Δp 2320 PSI and a rupture strength of Δp 3625 PSI.

Eaton filter are suitable for all petroleum based fluids, HW-emulsions, most synthetic hydraulic fluids and lubrication oils.

The internal valve is integrated into the filter head. After reaching the bypass pressure setting, the bypass valve will send unfiltered partial flow around the filter.

The reversing valve provides another level of protection for the filter element. The reverse flow will not be filtered.

1. Type index:

1.1. Complete filter: (ordering example)

EHPF. 360. 10VG. HR. E. P. VA. F. 5. VA. -. AE

1	2	3	4	5	6	7	8	9	10	11	12
---	---	---	---	---	---	---	---	---	----	----	----

1 | **series:**
EHPF = stainless steel-pressure filter, manifold mounted

2 | **nominal size:** 170, 240, 360, 450

3 | **filter material:**
80G, 40G, 25G stainless steel wire mesh
25VG, 16VG, 10VG, 6VG, 3VG microglass

4 | **filter element collapse rating:**
30 = Δp 435 PSI
HR = Δp 2320 PSI (rupture strength Δp 3625 PSI)

5 | **filter element design:**
E = single-end open

6 | **sealing material:**
P = Nitrile (NBR)
V = Viton (FPM)

7 | **filter element specification:**
- = standard
VA = stainless steel
IS06 = for HFC applications, see sheet-no. 31601

8 | **process connection:**
F = manifold mounted

9 | **process connection size:**
5 = 1"

10 | **filter housing specification:**
VA = stainless steel

11 | **internal valve:**
- = without
S1 = with by-pass valve Δp 51 PSI
S2 = with by-pass valve Δp 102 PSI
R = reversing valve, $Q \leq 55.75$ GPM

12 | **clogging indicator or clogging sensor:**
- = without
AOR = visual, see sheet-no. 1606
AOC = visual, see sheet-no. 1606
AE = visual-electric, see sheet-no. 1615
VS5 = electronic, see sheet-no. 1619

To add an indicator/sensor to your filter, use the corresponding indicator data sheet to find the indicator details and add them to the filter assembly model code.

1.2. Filter element: (ordering example)

01E. 360. 10VG. HR. E. P. VA

1	2	3	4	5	6	7
---	---	---	---	---	---	---

1 | **series:**
01E. = filter element according to company standard

2 | **nominal size:** 170, 240, 360, 450

3 | - **7** | see type index-complete filter

Technical data:

operating temperature:	+14 °F to +212 °F
operating medium	mineral oil, other media on request
max. operating pressure:	4568 PSI
test pressure:	6525 PSI
process connection:	manifold mounted
housing material:	EN10088-1.4571 (316 Ti according to AISI)
sealing material:	Nitrile (NBR) or Viton (FPM), other materials on request
installation position:	vertical

Classified under the Pressure Equipment Directive 2014/68/EU for mineral oil (fluid group 2), Article 4, Para. 3.
 Classified under ATEX Directive 2014/34/EU according to specific application (see questionnaire sheet-no. 34279-4).

Pressure drop flow curves:

Filter calculation/sizing

The pressure drop of the assembly at a given flow rate Q is the sum of the housing Δp and the element Δp and is calculated as follows:

$$\Delta p_{assembly} = \Delta p_{housing} + \Delta p_{element}$$

$$\Delta p_{housing} = (\text{see } \Delta p = f(Q) \text{ - characteristics})$$

$$\Delta p_{element} (PSI) = Q (GPM) \times \frac{MSK}{1000} \left(\frac{PSI}{GPM} \right) \times v(SUS) \times \frac{\rho}{0.876} \left(\frac{kg}{dm^3} \right)$$

For ease of calculation our Filter Selection tool is available online at www.eaton.com/hydraulic-filter-evaluation

Material gradient coefficients (MSK) for filter elements

The material gradient coefficients in psi/gpm apply to mineral oil (HLP) with a density of 0.876 kg/dm³ and a kinematic viscosity of 139 SUS (30 mm²/s). The pressure drop changes proportionally to the change in kinematic viscosity and density.

EHPF	VG					G		
	3VG	6VG	10VG	16VG	25VG	25G	40G	80G
170	2.714	1.884	1.206	1.036	0.708	0.0839	0.0783	0.0537
240	2.092	1.452	0.930	0.799	0.546	0.0651	0.0607	0.0416
360	1.530	1.062	0.680	0.584	0.399	0.0475	0.0444	0.0304
450	1.126	0.782	0.500	0.430	0.294	0.0349	0.0326	0.0223

$\Delta p = f(Q)$ – characteristics according to ISO 3968

The pressure drop characteristics apply to mineral oil (HLP) with a density of 0,876 kg/dm³. The pressure drop changes proportionally to the density.

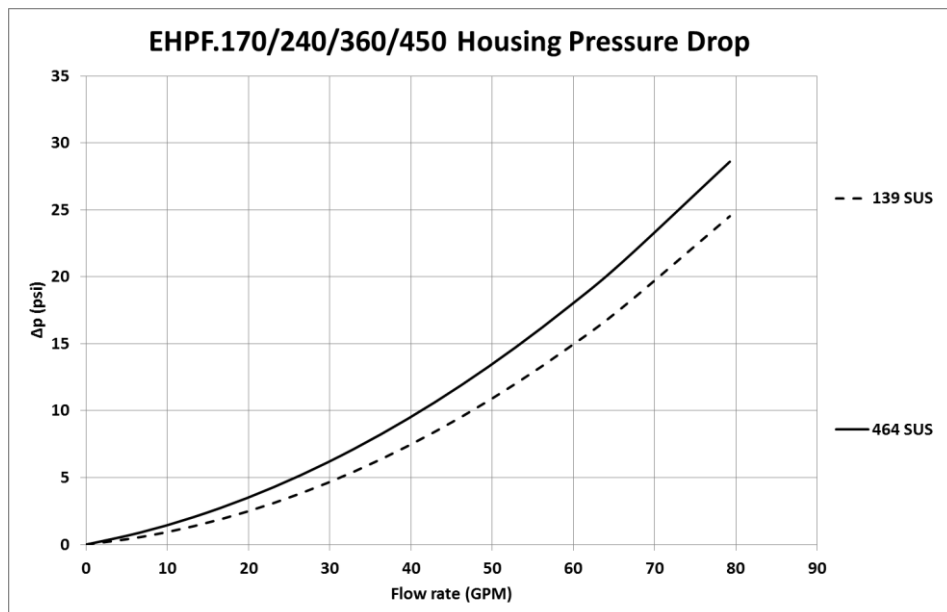

Symbols:

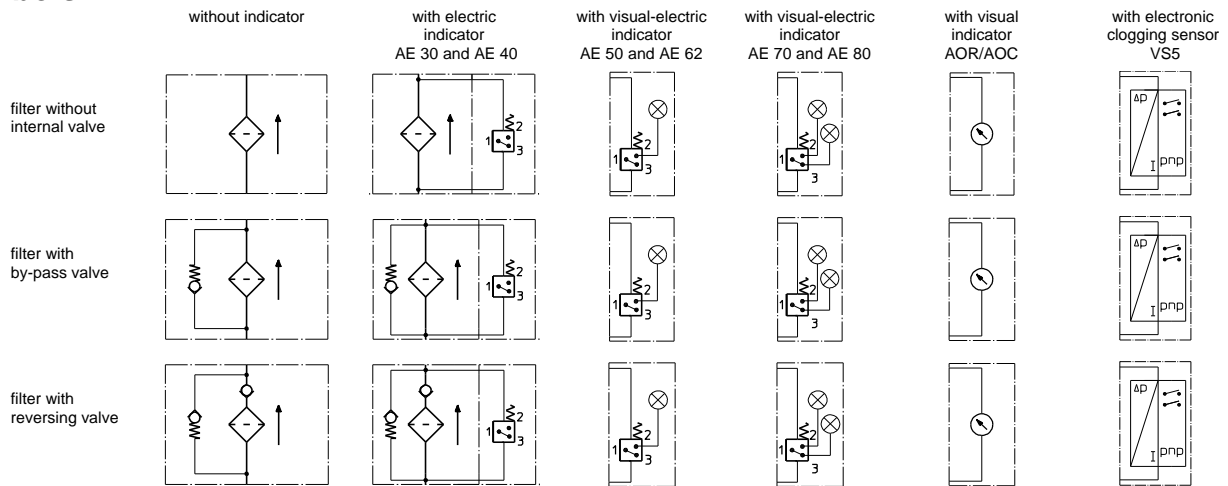

Spare parts:

item	qty.	designation	dimension				article-no.	
			EHPF 170	EHPF 240	EHPF 360	EHPF 450		
1	1	filter element	01E.170...	01E.240...	01E.360...	01E.450...		
2	1	O-ring	34 x 3,5				304338 (NBR)	304730 (FPM)
3	1	O-ring	76 x 4				305599 (NBR)	310291 (FPM)
4	1	support ring	84 x 3,6 x 1,5				312307	
5	2	O-ring	32 x 3				304368 (NBR)	311020 (FPM)
6	1	clogging indicator visual	AOR or AOC				siehe Blatt-Nr. 1606	
7	1	clogging indicator visual-electric	AE				siehe Blatt-Nr. 1615	
8	1	clogging sensor electronic	VS5				siehe Blatt-Nr. 1619	
9	1	screw plug	20913-4				314442	

item 9 execution only without clogging indicator or clogging sensor

Test methods:

Filter elements are tested according to the following ISO standards:

ISO 2941	Verification of collapse/burst resistance
ISO 2942	Verification of fabrication integrity
ISO 2943	Verification of material compatibility with fluids
ISO 3723	Method for end load test
ISO 3724	Verification of flow fatigue characteristics
ISO 3968	Evaluation of pressure drop versus flow characteristics
ISO 16889	Multi-pass method for evaluating filtration performance

North America
44 Apple Street
Tinton Falls, NJ 07724
Toll Free: 800 656-3344
(North America only)
Tel: +1 732 212-4700

Greater China
No. 7, Lane 280,
Linhong Road
Changning District, 200335
Shanghai, P.R. China
Tel: +86 21 5200-0099

Europe/Africa/Middle East
Auf der Heide 2
53947 Nettersheim, Germany
Tel: +49 2486 809-0

Friedensstraße 41
68804 Altlufheim, Germany
Tel: +49 6205 2094-0

Asia-Pacific
100G Pasir Panjang Road
#07-08 Interlocal Centre
Singapore 118523
Tel: +65 6825-1668

An den Nahewiesen 24
55450 Langenlonsheim, Germany
Tel: +49 6704 204-0

**For more information, please
email us at filtration@eaton.com
or visit www.eaton.com/filtration**

© 2021 Eaton. All rights reserved. All trademarks and registered trademarks are the property of their respective owners. All information and recommendations appearing in this brochure concerning the use of products described herein are based on tests believed to be reliable. However, it is the user's responsibility to determine the suitability for his own use of such products. Since the actual use by others is beyond our control, no guarantee, expressed or implied, is made by Eaton as to the effects of such use or the results to be obtained. Eaton assumes no liability arising out of the use by others of such products. Nor is the information herein to be construed as absolutely complete, since additional information may be necessary or desirable when particular or exceptional conditions or circumstances exist or because of applicable laws or government regulations.