

# Series EHPF 60-150 DN18 PN315

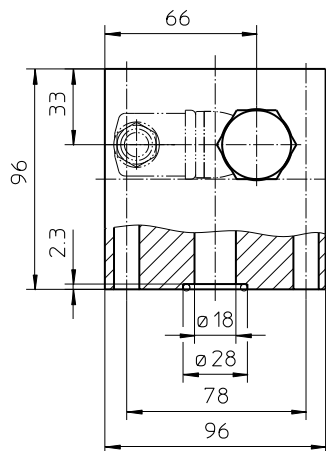
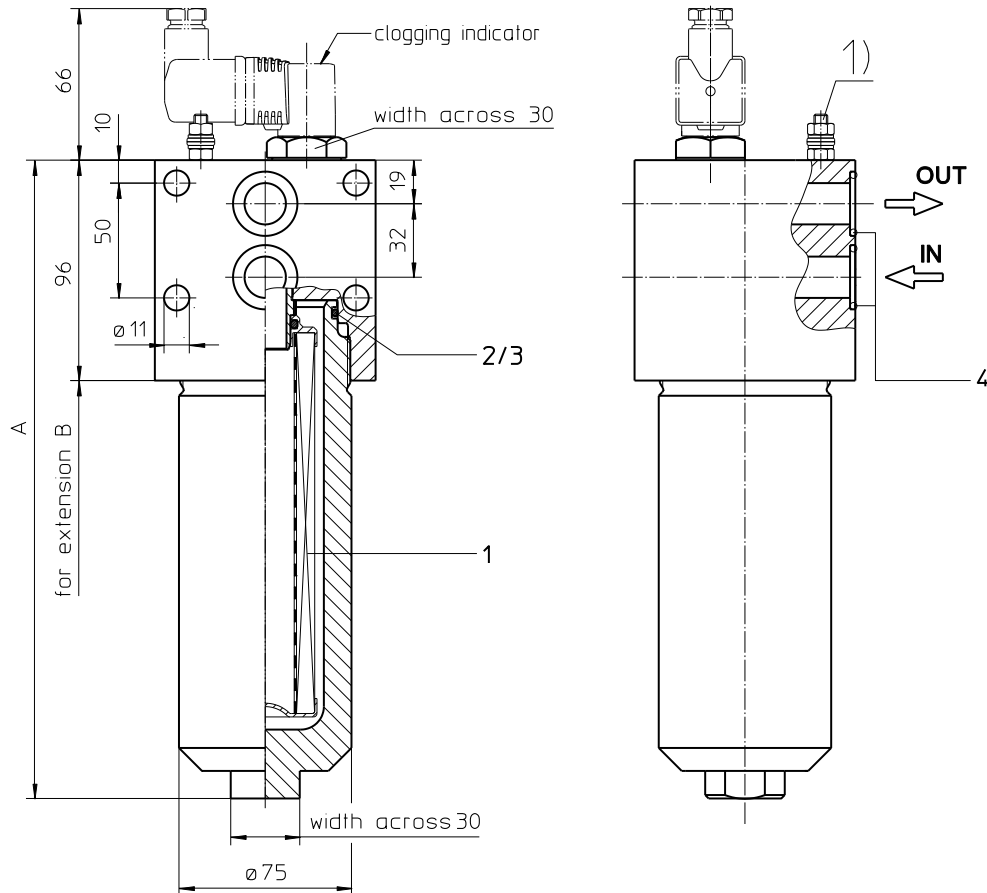

1) Connection for the potential equalization, only for application in the explosive area.

### Dimensions:

type	EHPF 60	EHPF 90	EHPF 150
connection	DN 18		
A	213	278	388
B	215	280	390
weight kg	10	11	13
volume tank	0,3 l	0,4 l	0,6 l

# Pressure Filter

## Series EHPF 60-150

### DN18 PN315

#### Description:

Stainless steel-pressure filter series EHPF 60-150 have a working pressure up to 315 bar. Pressure peaks can be absorbed with a sufficient safety margin. The EHPF-filters are flanged to the mounting-surface.

The filter element consists of star-shaped, pleated filter material, which is supported on the inside by a perforated core tube and is bonded to the end caps with a high-quality adhesive. The flow direction is from outside to inside. Filter elements are available down to 5  $\mu\text{m(c)}$ .

Eaton filter elements are known for high intrinsic stability and an excellent filtration capability, a high dirt-retaining capacity and a long service life.

Eaton filter elements are available up to a pressure resistance of  $\Delta p$  160 bar and a rupture strength of  $\Delta p$  250 bar.

Eaton filter are suitable for all petroleum based fluids, HW-emulsions, most synthetic hydraulic fluids and lubrication oils.

The internal valve is integrated into the filter head. After reaching the bypass pressure setting, the bypass valve will send unfiltered partial flow around the filter.

The reversing valve provides another level of protection for the filter element. The reverse flow will not be filtered.

## 1. Type index:

### 1.1. Complete filter: (ordering example)

**EHPF. 90. 10VG.HR. E. P. VA. F. 4. VA. - . - . AE**

1	2	3	4	5	6	7	8	9	10	11	12	13
---	---	---	---	---	---	---	---	---	----	----	----	----

- 1 series:**  
EHPF = stainless steel-pressure filter, manifold mounted
- 2 nominal size:** 60, 90, 150
- 3 filter-material:**  
80G, 40G, 25G stainless steel wire mesh  
25VG, 16VG, 10VG, 6VG, 3VG microglass
- 4 filter element collapse rating:**  
30 =  $\Delta p$  30 bar  
HR =  $\Delta p$  160 bar (rupture strength  $\Delta p$  250 bar)
- 5 filter element design:**  
E = single-end open
- 6 sealing material:**  
P = Nitrile (NBR)  
V = Viton (FPM)
- 7 filter element specification:**  
- = standard  
VA = stainless steel  
IS06 = for HFC applications, see sheet-no. 31601
- 8 process connection:**  
F = manifold mounted
- 9 process connection size:**  
4 = DN 18
- 10 filter housing specification:**  
VA = stainless steel
- 11 specification pressure vessel:**  
- = standard  
IS20 = ASME VIII Div.1 with ASME equivalent material, see sheet-no. 55217 (max. operating pressure 280 bar)
- 12 internal valve:**  
- = without  
S1 = with by-pass valve  $\Delta p$  3,5 bar  
S2 = with by-pass valve  $\Delta p$  7,0 bar  
R = reversing valve,  $Q \leq 70,06$  l/min
- 13 clogging indicator or clogging sensor:**  
- = without  
AOR = visual, see sheet-no. 1606  
AOC = visual, see sheet-no. 1606  
AE = visual-electric, see sheet-no. 1615  
VS5 = electronic, see sheet-no. 1619

To add an indicator/sensor to your filter, use the corresponding indicator data sheet to find the indicator details and add them to the filter assembly model code.

### 1.2. Filter element: (ordering example)

**01E. 90. 10VG.HR. E. P. VA**

1	2	3	4	5	6	7
---	---	---	---	---	---	---

- 1 series:**  
01E. = filter element according to company standard
- 2 nominal size:** 60, 90, 150
- 3 - 7** see type index-complete filter

## Technical data:

operating temperature:	-10°C to +100°C
operating medium	mineral oil, other media on request
max. operating pressure:	315 bar
test pressure:	450 bar
max. operating pressure at IS20:	280 bar
test pressure at IS20:	364 bar
process connection:	manifold mounted
housing material:	EN10088-1.4571 (320 S 18, 320 S 31 according to B.S.)
sealing material:	Nitrile (NBR) or Viton (FPM), other materials on request
installation position:	vertical

Classified under the Pressure Equipment Directive 2014/68/EU for mineral oil (fluid group 2), Article 4, Para. 3.  
 Classified under ATEX Directive 2014/34/EU according to specific application (see questionnaire sheet-no. 34279-4).

## Pressure drop flow curves:

### Filter calculation/sizing

The pressure drop of the assembly at a given flow rate Q is the sum of the housing  $\Delta p$  and the element  $\Delta p$  and is calculated as follows:

$$\Delta p_{assembly} = \Delta p_{housing} + \Delta p_{element}$$

$$\Delta p_{housing} = (\text{see } \Delta p = f(Q) - \text{characteristics})$$

$$\Delta p_{element} (mbar) = Q \left( \frac{l}{min} \right) \times \frac{MSK}{10} \left( \frac{mbar}{l/min} \right) \times \nu \left( \frac{mm^2}{s} \right) \times \frac{\rho}{0,876} \left( \frac{kg}{dm^3} \right)$$

For ease of calculation our Filter Selection tool is available online at [www.eaton.com/hydraulic-filter-evaluation](http://www.eaton.com/hydraulic-filter-evaluation)

### Material gradient coefficients (MSK) for filter elements

The material gradient coefficients in mbar/(l/min) apply to mineral oil (HLP) with a density of 0,876 kg/dm<sup>3</sup> and a kinematic viscosity of 30 mm<sup>2</sup>/s (139 SUS). The pressure drop changes proportionally to the change in kinematic viscosity and density.

EHPF	VG					G		
	3VG	6VG	10VG	16VG	25VG	25G	40G	80G
60	5,438	3,775	2,417	2,104	1,438	0,2205	0,1635	0,1526
90	3,271	2,271	1,454	1,266	0,865	0,1333	0,0988	0,0922
150	1,952	1,355	0,867	0,755	0,516	0,0796	0,0590	0,0551

### $\Delta p = f(Q)$ – characteristics according to ISO 3968

The pressure drop characteristics apply to mineral oil (HLP) with a density of 0,876 kg/dm<sup>3</sup>. The pressure drop changes proportionally to the density.

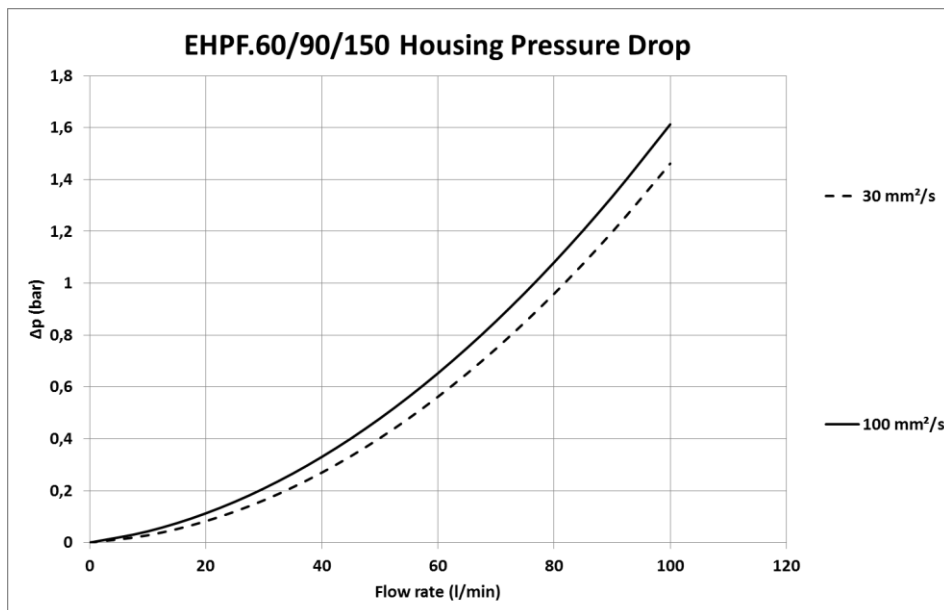

## Symbols:

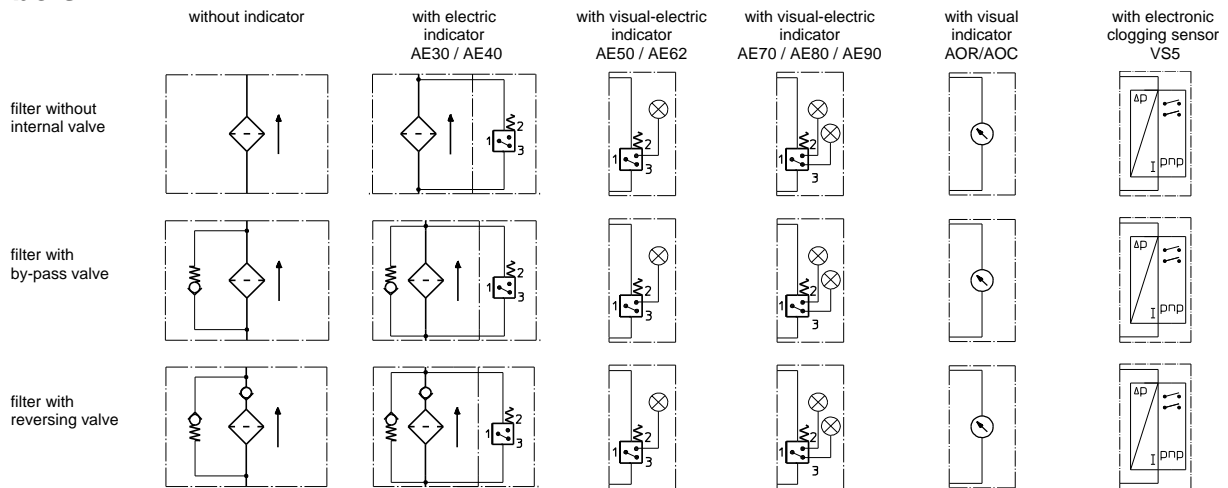

## Spare parts:

item	qty.	designation	dimension			article-no.	
			EHPF 60 01E.60...	EHPF 90 01E.90...	EHPF 150 01E.150...		
1	1	filter element					
2	1	O-ring	56 x 3			305072 (NBR)	305322 (FPM)
3	1	support ring	63 x 2,6 x 1			312309	
4	2	O-ring	22 x 3			304387 (NBR)	304931 (FPM)

## Test methods:

Filter elements are tested according to the following ISO standards:

ISO 2941	Verification of collapse/burst resistance
ISO 2942	Verification of fabrication integrity
ISO 2943	Verification of material compatibility with fluids
ISO 3723	Method for end load test
ISO 3724	Verification of flow fatigue characteristics
ISO 3968	Evaluation of pressure drop versus flow characteristics
ISO 16889	Multi-pass method for evaluating filtration performance

### North America

44 Apple Street  
Tinton Falls, NJ 07724  
Toll Free: 800 656-3344  
(North America only)  
Tel: +1 732 212-4700

### Greater China

No. 7, Lane 280,  
Linhong Road  
Changning District, 200335  
Shanghai, P.R. China  
Tel: +86 21 5200-0099

### Europe/Africa/Middle East

Auf der Heide 2  
53947 Nettersheim, Germany  
Tel: +49 2486 809-0

Friedensstraße 41  
68804 Altlufheim, Germany  
Tel: +49 6205 2094-0

An den Nahewiesen 24  
55450 Langenlonsheim, Germany  
Tel: +49 6704 204-0

### Asia-Pacific

100G Pasir Panjang Road  
#07-08 Interlocal Centre  
Singapore 118523  
Tel: +65 6825-1668

For more information, please

email us at [filtration@eaton.com](mailto:filtration@eaton.com)

or visit [www.eaton.com/filtration](http://www.eaton.com/filtration)

© 2022 Eaton. All rights reserved. All trademarks and registered trademarks are the property of their respective owners. All information and recommendations appearing in this brochure concerning the use of products described herein are based on tests believed to be reliable. However, it is the user's responsibility to determine the suitability for his own use of such products. Since the actual use by others is beyond our control, no guarantee, expressed or implied, is made by Eaton as to the effects of such use or the results to be obtained. Eaton assumes no liability arising out of the use by others of such products. Nor is the information herein to be construed as absolutely complete, since additional information may be necessary or desirable when particular or exceptional conditions or circumstances exist or because of applicable laws or government regulations.