

Series EHD 61-151

4568 PSI

Dimensions:

type	EHD 61	EHD 91	EHD 151
connection	G 1		
A	8.81	11.37	15.70
B	8.26	13.38	17.71
weight lbs.	68	75	84
volume tank	2x .06 Gal.	2x .10 Gal.	2x .15 Gal.

- 1) Connection for the potential equalization, only for application in the explosive area.

Connections V and VI to be used for pressure relief and air bleeding respective filter side.

Position I: left filter side in operation
 Position II: right filter side in operation

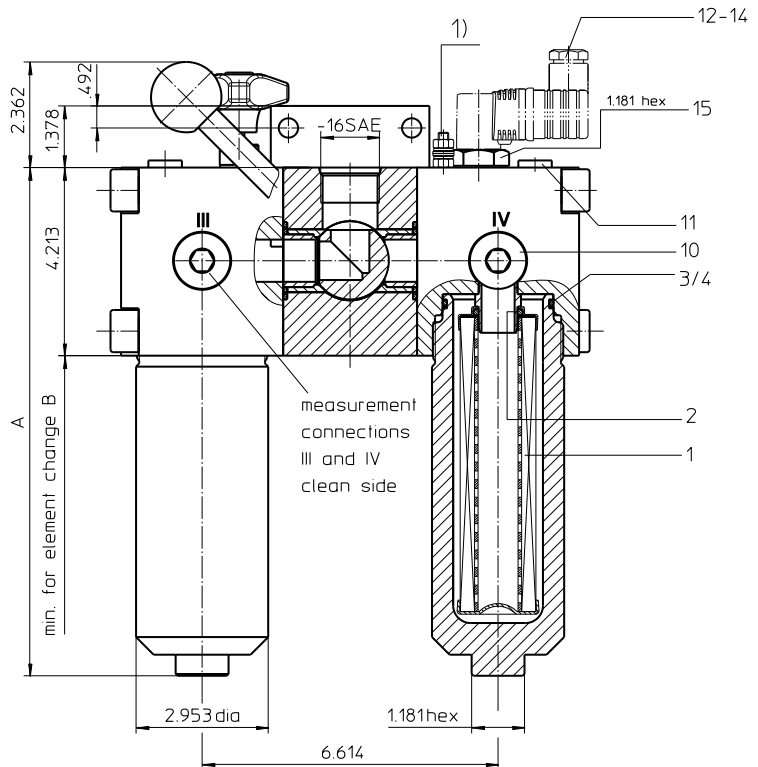
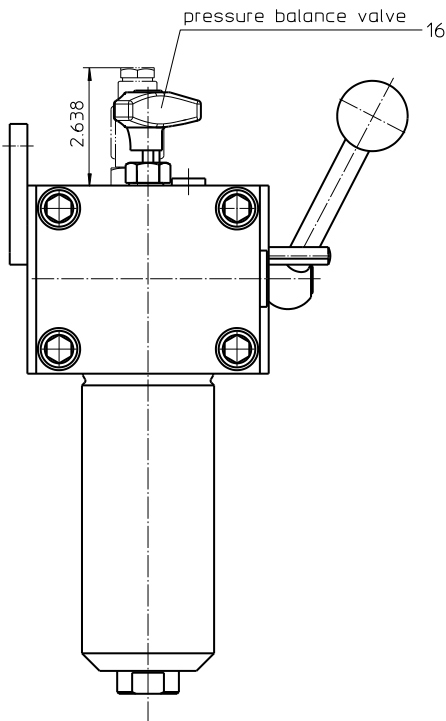
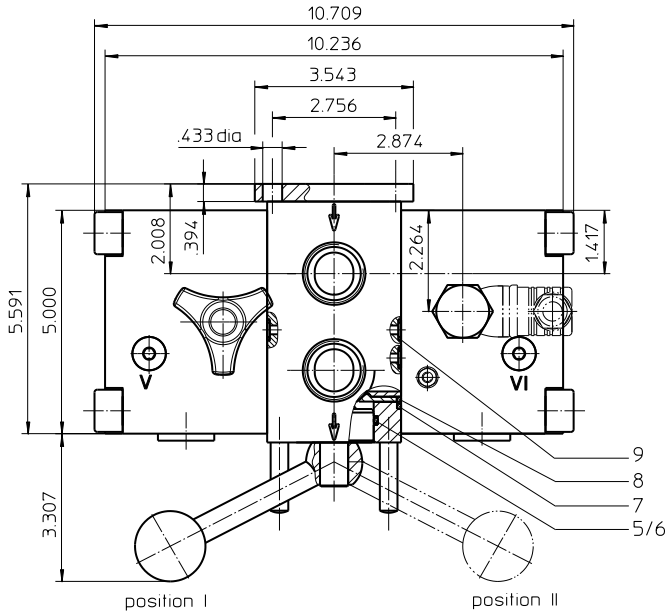

Dimensions: inches

Designs and performance values are subject to change.

Pressure Filter, change over Series EHD 61-151 4568 PSI

Description:

Stainless steel-pressure filters change over series EHD 61-151 are suitable for operating pressure up to 4568 PSI. The pressure peaks are absorbed by a sufficient margin of safety.

Duplex filters can be serviced without interruption of operation. The upper part has a three-way-change-over valve which allows to change-over the flow from the dirty filter-side to the clean filter-side without interrupting the operation. The change-over procedure does not lead to a cross sectional contraction. Prior to the change-over procedure a built-in pressure balance valve equalizes the housing pressure. After change-over the pressure balance valve is to be closed again. The closed filter-side has to be air-bled by vent V respectively by vent VI. Then change filter element. After screw in the filter bowl the pressure balance has to be opened shortly and the just serviced filter-side has to be air-bled. Filter elements are available down to a filter fineness of $5 \mu\text{m}_{(C)}$.

Eaton filter elements are known for high intrinsic stability and an excellent filtration capability, a high dirt-retaining capacity and a long service life.

Eaton filter elements are available with a pressure difference resistance up to Δp 2320 PSI and a rupture strength up to Δp 3625 PSI.

The internal valves are integrated into the centering pivot for the filter element.

After reaching the opening pressure the by-pass valve causes that an unfiltered partial flow passes the filter. The reversing valve provides another level of protection for the filter element. The reverse flow will not be filtered.

Eaton filter are suitable for all petroleum based fluids, HW-emulsions, most synthetic hydraulic fluids and lubrication oils.

1. Type index:

1.1. Complete filter: (ordering example)

EHD.	91.	10VG.	HR.	E.	P.	VA.	UG.	5.	VA.	-.	-.	AE
1	2	3	4	5	6	7	8	9	10	11	12	13

1 series:

ÉHD = stainless steel-pressure filter, change over

2 nominal size: 61, 91, 151

3 filter-material and filter-fineness:

80G, 40G, 25G stainless steel wire mesh
25VG, 16VG, 10VG, 6VG, 3VG microglass

4 filter element collapse rating:

30 = Δp 435 PSI
HR = Δp 2320 PSI (rupture strength Δp 3625 PSI)

5 filter element design:

E = single-end open

6 sealing material:

P = Nitrile (NBR)
V = Viton (FPM)

7 filter element specification:

- = standard
VA = stainless steel

8 process connection:

UG = thread connection

9 process connection size:

5 = -16 SAE

10 filter housing specification:

VA = stainless steel

11 specification pressure vessel:

- = standard (PED 2014/68/EU)
IS20 = ASME VIII Div.1 with ASME equivalent material, see sheet-no. 55217 (max. operating pressure 2635 PSI)

12 internal valve:

- = without
S1 = with by-pass valve Δp 51 PSI
S2 = with by-pass valve Δp 102 PSI
R = reversing valve, $Q \leq 18.50$ GPM

13 clogging indicator or clogging sensor:

- = without
AOR = visual, see sheet-no. 1606
AOC = visual, see sheet-no. 1606
AE = visual-electric, see sheet-no. 1615
VS5 = electronic, see sheet-no. 1619

To add an indicator to your filter, use the corresponding indicator data sheet to find the indicator details and add them to the filter assembly model code.

1.2. Filter element: (ordering example)

01E.	90.	10VG.	HR.	E.	P.	VA
1	2	3	4	5	6	7

1 series:

01E. = filter element according to company standard

2 nominal size: 60, 90, 150

3 - 7 see type index-complete filter

Accessories:

- gauge port- and bleeder connection, see sheet-no. 1650

Technical data:

operating temperature:	+14°F to +212°F
operating medium	mineral oil, other media on request
max. operating pressure:	4568 PSI
test pressure:	6532 PSI
max. operating pressure at IS20:	3625 PSI
test pressure at IS20:	4713 PSI
process connection:	thread connection
housing material:	EN10088-1.4571 (316 Ti according to AISI)
sealing material:	Nitrile (NBR) or Viton (FPM), other materials on request
installation position:	vertical
air bleeding and measure connections dirt side:	BSPP ¼
measure connections clean side:	BSPP ¼

Classified under the Pressure Equipment Directive 2014/68/EU for mineral oil (fluid group 2), Article 4, Para. 3.
 Classified under ATEX Directive 2014/34/EU according to specific application (see questionnaire sheet-no. 34279-4).

Pressure drop flow curves:

Filter calculation/sizing

The pressure drop of the assembly at a given flow rate Q is the sum of the housing Δp and the element Δp and is calculated as follows:

$$\Delta p_{assembly} = \Delta p_{housing} + \Delta p_{element}$$

$$\Delta p_{housing} = (\text{see } \Delta p = f(Q) \text{ - characteristics})$$

$$\Delta p_{element} (PSI) = Q (GPM) \times \frac{MSK}{1000} \left(\frac{PSI}{GPM} \right) \times \nu (SUS) \times \frac{\rho}{0.876} \left(\frac{kg}{dm^3} \right)$$

For ease of calculation our Filter Selection tool is available online at www.eaton.com/hydraulic-filter-evaluation

Material gradient coefficients (MSK) for filter elements

The material gradient coefficients in psi/gpm apply to mineral oil (HLP) with a density of 0.876 kg/dm³ and a kinematic viscosity of 139 SUS (30 mm²/s). The pressure drop changes proportionally to the change in kinematic viscosity and density.

EHD	VG					G		
	3VG	6VG	10VG	16VG	25VG	25G	40G	80G
61	6.748	4.685	2.999	2.577	1.760	0.2002	0.1868	0.1280
91	4.059	2.818	1.804	1.550	1.059	0.1210	0.1130	0.0774
151	2.422	1.681	1.076	0.925	0.632	0.0723	0.0675	0.0462

$\Delta p = f(Q)$ – characteristics according to ISO 3968

The pressure drop characteristics apply to mineral oil (HLP) with a density of 0.876 kg/dm³. The pressure drop changes proportionally to the density.

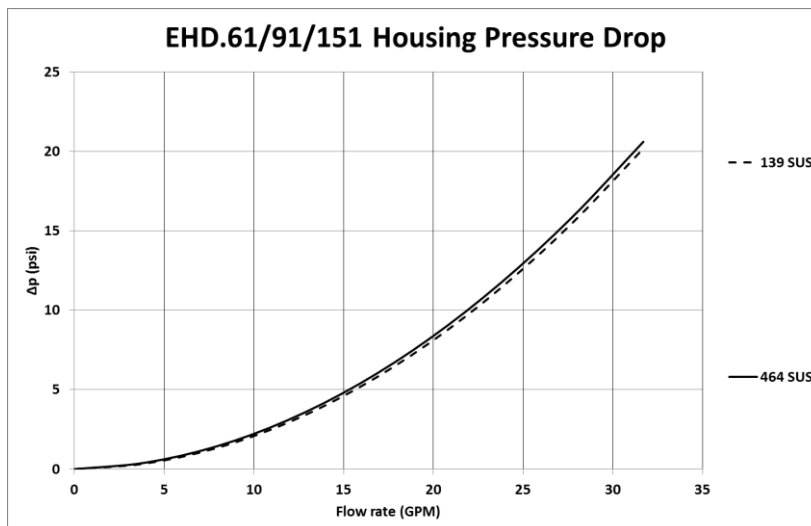

Symbols:

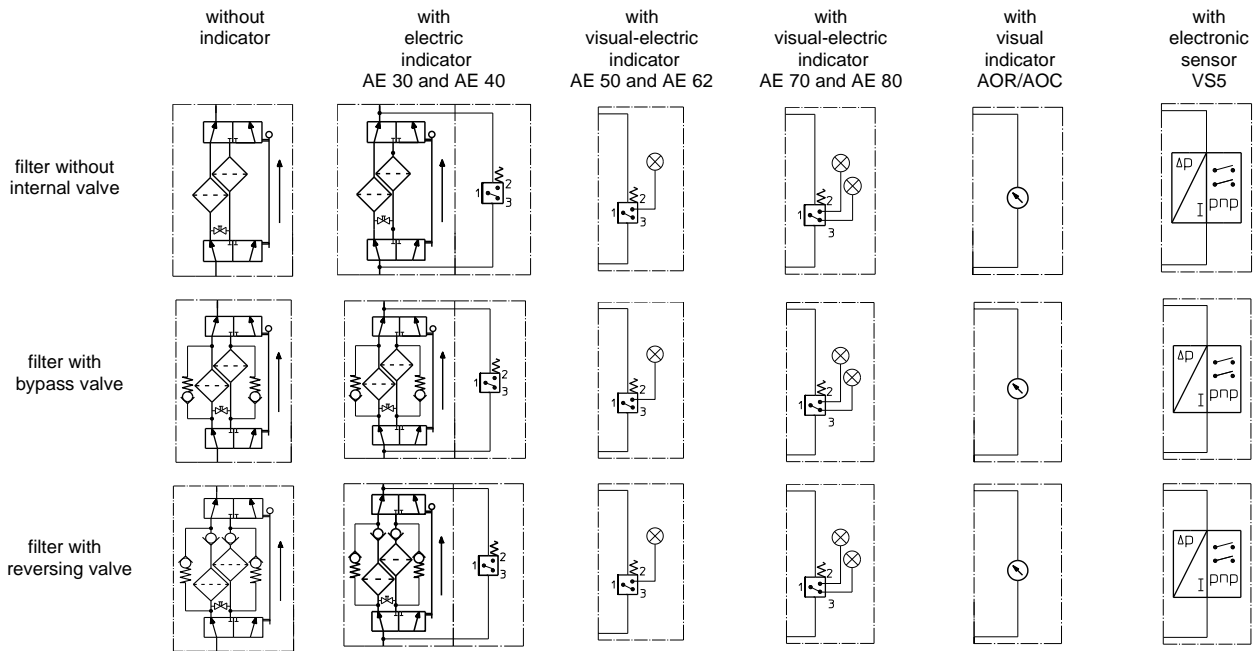

Spare parts:

item	qty.	designation	dimension			article-no.	
			EHD 61	EHD 91	EHD 151		
1	2	filter element	01E.60...	01E.90...	01E.150 ...		
2	2	O-ring		22 x 3,5		304341 (NBR)	304392 (FPM)
3	2	O-ring		56 x 3		305072 (NBR)	305322 (FPM)
4	2	support ring		63 x 2,6 x 1		312309	
5	3	O-ring		45 x 3		304991 (NBR)	304997 (FPM)
6	2	support ring		49,7 x 2,4 x 1		317709	
7	4	O-ring		38 x 3		304340 (NBR)	317013 (FPM)
8	4	O-ring		28 x 3		316778 (NBR)	318366 (FPM)
9	4	O-ring		8 x 2		310004 (NBR)	316530 (FPM)
10	2	screw plug		¼ BSPP		313815	
11	2	screw plug		¼ BSPP		306968	
12	1	clogging indicator, visual		AOR or AOC		see sheet-no. 1606	
13	1	clogging indicator, visual-electric		AE		see sheet-no. 1615	
14	1	clogging sensor, electronic		VS5		see sheet-no. 1619	
15	1	screw plug		20913-4		314442	
16	1	pressure balance valve		3/8"		310316	

item 15 execution only without clogging indicator or clogging sensor

Test methods:

Filter elements are tested according to the following ISO standards:

ISO 2941	Verification of collapse/burst resistance
ISO 2942	Verification of fabrication integrity
ISO 2943	Verification of material compatibility with fluids
ISO 3723	Method for end load test
ISO 3724	Verification of flow fatigue characteristics
ISO 3968	Evaluation of pressure drop versus flow characteristics
ISO 16889	Multi-pass method for evaluating filtration performance

North America
44 Apple Street
Tinton Falls, NJ 07724
Toll Free: 800 656-3344
(North America only)
Tel: +1 732 212-4700

Greater China
No. 7, Lane 280,
Linhong Road
Changning District, 200335
Shanghai, P.R. China
Tel: +86 21 5200-0099

Europe/Africa/Middle East
Auf der Heide 2
53947 Nettersheim, Germany
Tel: +49 2486 809-0

Asia-Pacific
100G Pasir Panjang Road
#07-08 Interlocal Centre
Singapore 118523
Tel: +65 6825-1668

Friedensstraße 41
68804 Altlußheim, Germany
Tel: +49 6205 2094-0
An den Nahewiesen 24
55450 Langenlonsheim, Germany
Tel: +49 6704 204-0

**For more information, please
email us at filtration@eaton.com
or visit www.eaton.com/filtration**

© 2021 Eaton. All rights reserved. All trademarks and registered trademarks are the property of their respective owners. All information and recommendations appearing in this brochure concerning the use of products described herein are based on tests believed to be reliable. However, it is the user's responsibility to determine the suitability for his own use of such products. Since the actual use by others is beyond our control, no guarantee, expressed or implied, is made by Eaton as to the effects of such use or the results to be obtained. Eaton assumes no liability arising out of the use by others of such products. Nor is the information herein to be construed as absolutely complete, since additional information may be necessary or desirable when particular or exceptional conditions or circumstances exist or because of applicable laws or government regulations.