

# Series EHD 601-1351

## 3045 PSI

**Dimensions:**

type	EHD 601	EHD 901	EHD 1351
connection	2"		
A	21.85	27.75	37.52
B	12.20	18.11	27.95
weight lbs.	330	352	485
volume tank	2x .55 Gal.	2x .82 Gal.	2x 1.21 Gal.

- 1) Connection for the potential equalization, only for application in the explosive area.

Measurement connections III and IV to be used for pressure relief and air bleeding respective filter side.

Position I: left filter side in operation  
 Position II: right filter side in operation

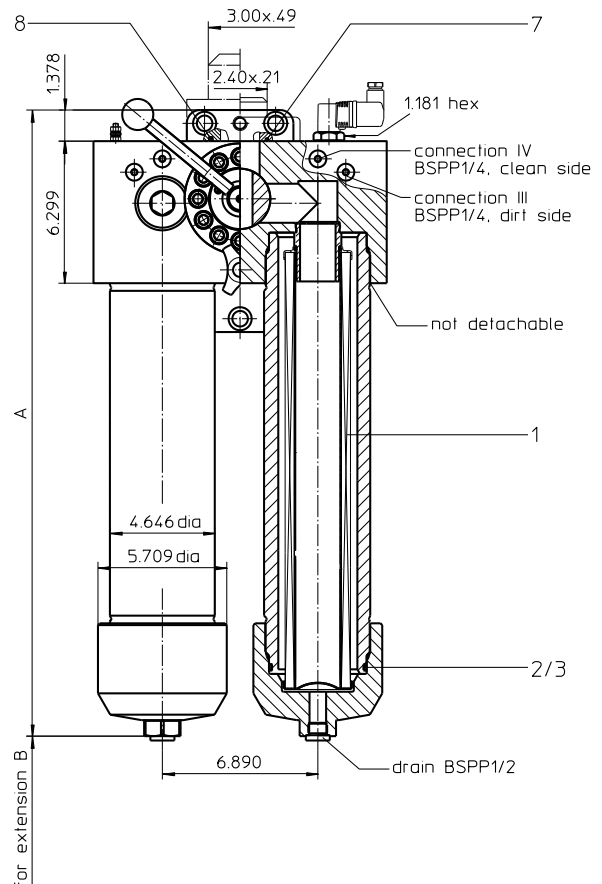
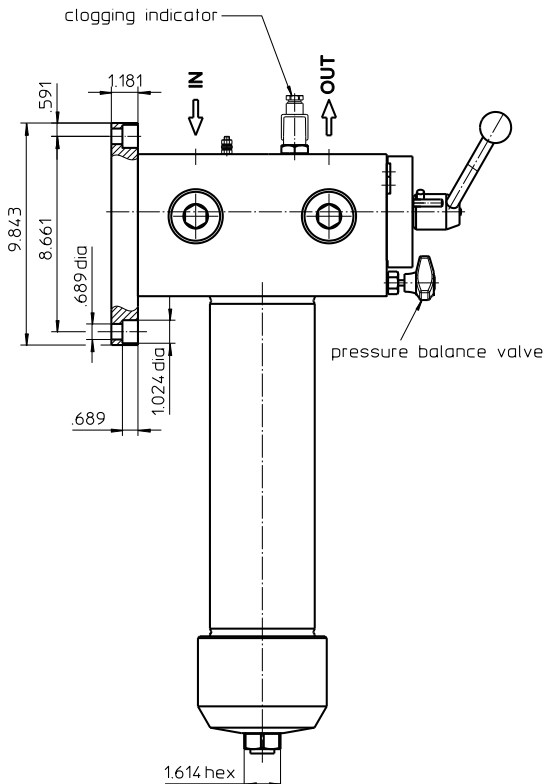
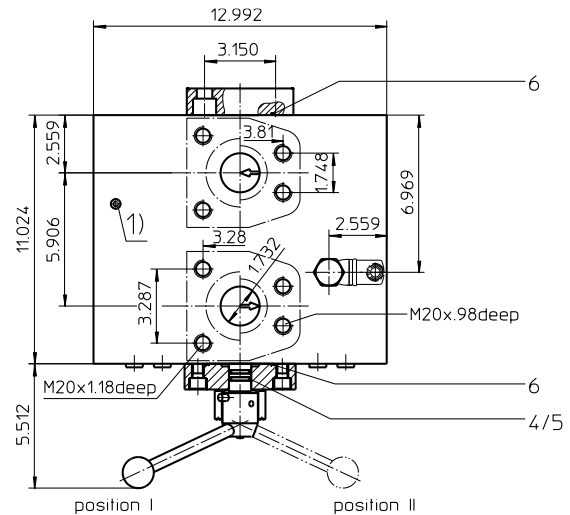

# Pressure Filter, change over Series EHD 601-1351 3045PSI

## Description:

Stainless steel-pressure filters change over series EHD 601-1351 are suitable for operating pressure up to 3045 PSI. The pressure peaks are absorbed by a sufficient margin of safety.

Duplex filters can be maintained without interruption. The upper part has a three-way-change-over valve which allows to change-over the flow from the dirty filter-side to the clean filter-side without interrupting the operation. The change-over procedure does not lead to a reduction of area.

The change-over can be done easily by opening of the change-over valve.

The mini-measuring connections on each filter-side allow the measuring of the pressure drop through the filter element, as well as at the pressure discharge of the tube plug during the maintenance. Filter elements are available down to a filter fineness of 5  $\mu\text{m(c)}$ .

Eaton filter elements are known for high intrinsic stability and an excellent filtration capability, a high dirt-retaining capacity and a long service life.

Eaton filter elements are available up to a pressure resistance of  $\Delta p$  2320 PSI and a rupture strength of  $\Delta p$  3625 PSI.

Eaton filter can be used for petroleum-based fluids, HW emulsions, water glycols, most synthetic fluids and lubrication fluids. Consult factory for specific fluid applications.

The internal valve is integrated into the filter head. After reaching the bypass pressure setting, the bypass valve will send unfiltered partial flow around the filter.

The reversing valve provides another level of protection for the filter element. The reverse flow will not be filtered.

## Type index:

**Complete filter:** (ordering example)

**EHD. 901. 10VG. HR. E. P. VA. FS. 8. VA. -. -. AE**

1	2	3	4	5	6	7	8	9	10	11	12	13
---	---	---	---	---	---	---	---	---	----	----	----	----

- |    |  |
|----|--|
| 1  | <b>series:</b><br>EHD = stainless steel-pressure filter change over  |
| 2  | <b>nominal size:</b> 601, 901, 1351  |
| 3  | <b>filter material:</b><br>80G, 40G, 25G stainless steel wire mesh<br>25VG, 16VG, 10VG, 6VG, 3VG microglass  |
| 4  | <b>filter element collapse rating:</b><br>30 = $\Delta p$ 435 PSI<br>HR = $\Delta p$ 2320 PSI (rupture strength $\Delta p$ 3625 PSI)   |
| 5  | <b>filter element design:</b><br>E = single-end open   |
| 6  | <b>sealing material:</b><br>P = Nitrile (NBR)<br>V = Viton (FPM)   |
| 7  | <b>filter element specification:</b><br>- = standard<br>VA = stainless steel   |
| 8  | <b>process connection:</b><br>FS = SAE-flange connection 6000 PSI (standard)<br>FV = AVIT-flange connection 4640 PSI (special design)  |
| 9  | <b>process connection size:</b><br>8 = 2"  |
| 10 | <b>filter housing specification:</b><br>VA = stainless steel   |
| 11 | <b>specification pressure vessel:</b><br>- = standard (PED 2014/68/EU)<br>IS20 = ASME VIII Div.1 with ASME equivalent material, see sheet-no. 55217 (max. operating pressure 3045 PSI)                                   |
| 12 | <b>internal valve:</b><br>- = without<br>S1 = with bypass valve $\Delta p$ 51 PSI<br>S2 = with bypass valve $\Delta p$ 102 PSI<br>R = reversing valve, $Q \leq 122.94$ GPM   |
| 13 | <b>clogging indicator or clogging sensor:</b><br>- = without<br>AOR = visual, see sheet-no. 1606<br>AOC = visual, see sheet-no. 1606<br>AE = visual-electric, see sheet-no. 1615<br>VS5 = electronic, see sheet-no. 1619 |

To add an indicator/sensor to your filter, use the corresponding indicator data sheet to find the indicator details and add them to the filter assembly model code.

**Filter element:** (ordering example)

**01E. 900. 10VG. HR. E. P. VA**

1	2	3	4	5	6	7
---	---	---	---	---	---	---

- |   |  |
|---|--|
| 1 | <b>series:</b><br>01E = filter element according to company standard |
| 2 | <b>nominal size:</b> 600, 900, 1350                                  |
| 3 | - 7   see type index-complete filter                                 |

## Accessories:

- gauge port- and bleeder connections, see sheet-no. 1650
- SAE-counter flange, see sheet-no. 1652
- AVIT-counter flange, see sheet-no. 1654

## Technical data:

operating temperature:	+14 °F to +212 °F
operating medium	mineral oil, other media on request
max. operating pressure:	3045 PSI
test pressure:	4350 PSI
max. operating pressure at IS20:	3045 PSI
test pressure at IS20:	3960 PSI
process connection:	SAE-flange 6000 PSI (standard) or AVIT-flange 4640 PSI (special design)
housing material:	EN10088-1.4571 (316 Ti according to AISI)
sealing material:	Nitrile (NBR) or Viton (FPM), other materials on request
installation position:	vertical
bleeder- and measuring connections:	BSPP ¼

Classified under the Pressure Equipment Directive 2014/68/EU for mineral oil (fluid group 2), Article 4, Para. 3.  
Classified under ATEX Directive 2014/34/EU according to specific application (see questionnaire sheet-no. 34279-4).

## Pressure drop flow curves:

### Filter calculation/sizing

The pressure drop of the assembly at a given flow rate Q is the sum of the housing  $\Delta p$  and the element  $\Delta p$  and is calculated as follows:

$$\Delta p_{assembly} = \Delta p_{housing} + \Delta p_{element}$$

$$\Delta p_{housing} = (\text{see } \Delta p = f(Q) \text{ - characteristics})$$

$$\Delta p_{element} (PSI) = Q (GPM) \times \frac{MSK}{1000} \left( \frac{PSI}{GPM} \right) \times v (SUS) \times \frac{\rho}{0.876} \left( \frac{kg}{dm^3} \right)$$

For ease of calculation our Filter Selection tool is available online at [www.eaton.com/hydraulic-filter-evaluation](http://www.eaton.com/hydraulic-filter-evaluation)

### Material gradient coefficients (MSK) for filter elements

The material gradient coefficients in psi/gpm apply to mineral oil (HLP) with a density of 0.876 kg/dm<sup>3</sup> and a kinematic viscosity of 139 SUS (30 mm<sup>2</sup>/s). The pressure drop changes proportionally to the change in kinematic viscosity and density.

EHD	VG					G		
	3VG	6VG	10VG	16VG	25VG	25G	40G	80G
601	0.963	0.669	0.428	0.368	0.251	0.0303	0.0282	0.0193
901	0.668	0.464	0.297	0.225	0.174	0.0189	0.0177	0.0121
1351	0.417	0.290	0.185	0.185	0.109	0.0122	0.0114	0.0078

### $\Delta p = f(Q)$ – characteristics according to ISO 3968

The pressure drop characteristics apply to mineral oil (HLP) with a density of 0,876 kg/dm<sup>3</sup>. The pressure drop changes proportionally to the density.

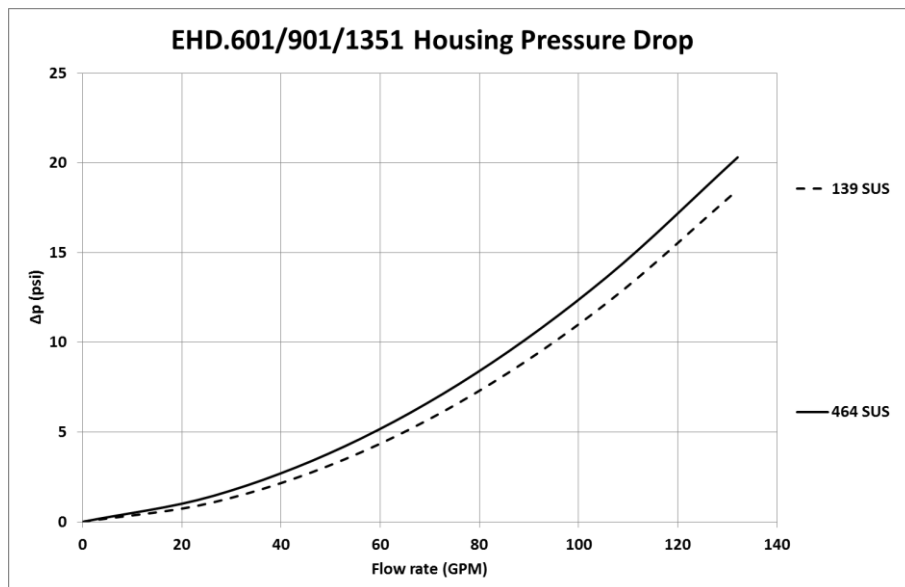

## Symbols:

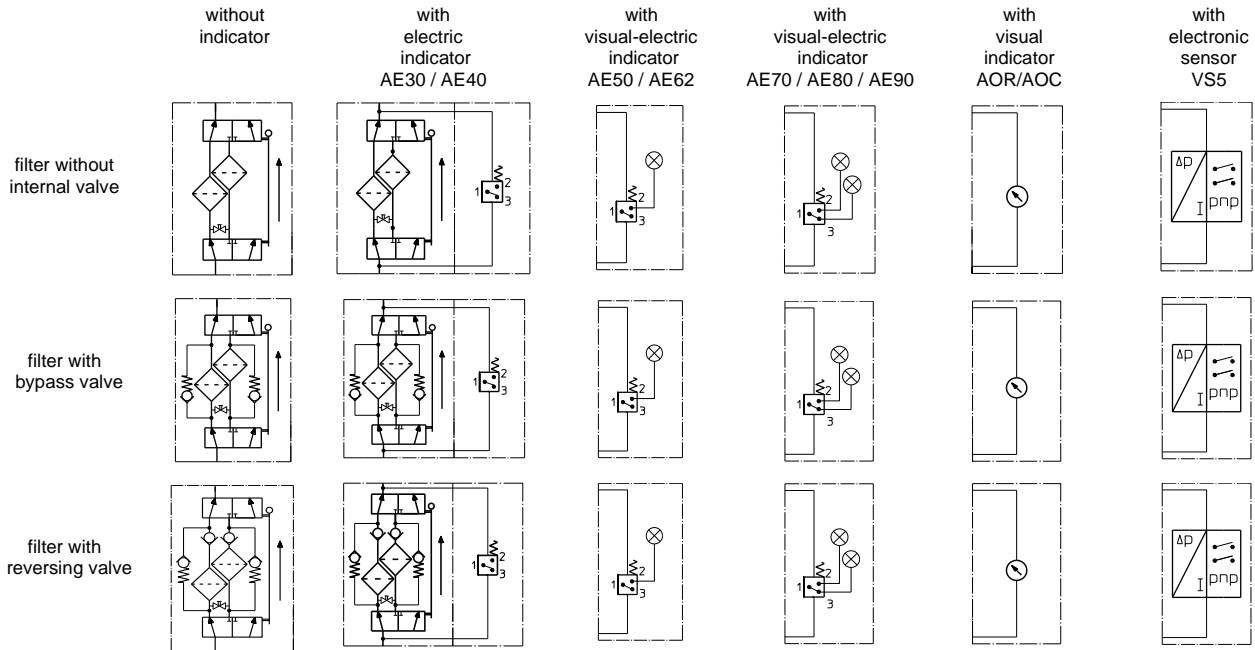

## Spare parts:

item	qty.	designation	dimension			article-no.	
			EHD 601 01E.600...	EHD 901 01E.900...	EHD 1351 01E.1350...		
1	2	filter element					
2	2	O-ring		98 x 4		301914 (NBR)	304765 (FPM)
3	2	support ring		110 x 3,5 x 2		304802	
4	2	O-ring		18 x 3		304359 (NBR)	304399 (FPM)
5	2	support ring		25 x 2,5 x 0,5		311311	
6	2	O-ring		71 x 3		306451 (NBR)	306897 (FPM)
7	2	O-ring (only with counter flange SAE)		56,75 x 3,53		306035 (NBR)	310264 (FPM)
8	2	O-ring (only with counter flange AVIT)		61 x 5			

## Test methods:

Filter elements are tested according to the following ISO standards:

ISO 2941	Verification of collapse/burst resistance
ISO 2942	Verification of fabrication integrity
ISO 2943	Verification of material compatibility with fluids
ISO 3723	Method for end load test
ISO 3724	Verification of flow fatigue characteristics
ISO 3968	Evaluation of pressure drop versus flow characteristics
ISO 16889	Multi-pass method for evaluating filtration performance

**North America**  
44 Apple Street  
Tinton Falls, NJ 07724  
Toll Free: 800 656-3344  
(North America only)  
Tel: +1 732 212-4700

**Greater China**  
No. 7, Lane 280,  
Linhong Road  
Changning District, 200335  
Shanghai, P.R. China  
Tel: +86 21 5200-0099

**Europe/Africa/Middle East**  
Auf der Heide 2  
53947 Nettersheim, Germany  
Tel: +49 2486 809-0

**Asia-Pacific**  
100G Pasir Panjang Road  
#07-08 Interlocal Centre  
Singapore 118523  
Tel: +65 6825-1668

Friedensstraße 41  
68804 Altludersheim, Germany  
Tel: +49 6205 2094-0

An den Nahewiesen 24  
55450 Langenlonsheim, Germany  
Tel: +49 6704 204-0

**EATON**  
Powering Business Worldwide

For more information, please  
email us at [filtration@eaton.com](mailto:filtration@eaton.com)  
or visit [www.eaton.com/filtration](http://www.eaton.com/filtration)

© 2021 Eaton. All rights reserved. All trademarks and registered trademarks are the property of their respective owners. All information and recommendations appearing in this brochure concerning the use of products described herein are based on tests believed to be reliable. However, it is the user's responsibility to determine the suitability for his own use of such products. Since the actual use by others is beyond our control, no guarantee, expressed or implied, is made by Eaton as to the effects of such use or the results to be obtained. Eaton assumes no liability arising out of the use by others of such products. Nor is the information herein to be construed as absolutely complete, since additional information may be necessary or desirable when particular or exceptional conditions or circumstances exist or because of applicable laws or government regulations.