

This manual is effective for all standard and customized filters of the series:

- HDD // HDN(L) // MDD
- Filter battery BHDD 901-1351
- Filter battery BHDNL 401
- EHD

The manual contains certain requirements and instructions which ensure an unobjectionable operation of the filter. If necessary, it can be complemented by additional, specific instructions of the operator. The pressure filters listed above are intended for filtration of liquid media.

1. Safety instructions

- The operating and maintenance instructions must be read carefully before working on the filter.
- The instructions in this manual must be followed!
- The manufacturer assumes no liability for damage caused by deviations from this manual..
- If actions are performed differently than described, the safety of the pressure equipment is not guaranteed!
- The operating parameters specified in the data sheet, in particular operating pressure, operating temperature range and operating medium, must be observed. Deviations from these parameters can damage pressure-bearing parts and seals. The compatibility of the filter components with the operating medium must be observed.
- The filter is under pressure in the operating state. No components of the filter may be loosened or removed during operation. Operating medium can escape under high pressure and at high temperature. This does not include components on the pressure-relieved or switched-off side of the housing.
- There is a risk of injury and scalding from the operating medium escaping!
- The filter housing must not be opened before it is ensured that it is no longer under pressure!
- Touching components of the filter can cause burns, depending on the operating temperature.
- Attention when changing the filter elements! Filter housing might still have operating temperature. Risk of burn!
- Always wear protective gloves and safety glasses when working on the filter!
- If you come into contact with the operating medium, the manufacturer's instructions must be observed!
- Only original spare parts may be used.

For filters that are installed in potentially explosive areas, additional requirements apply according to Eaton Documentation No. 41269 "Supplement to the operating and maintenance instructions for the use of filters in potentially explosive areas".

2. Installation

The filter is supplied ready for installation. It has to be fitted preferably tensionless on a flat and vertical surface, in the position as shown on its corresponding data sheet.

For connecting the filter to the piping system, attention has to be paid that

1. no dirt, no debris or fluids reach the inlet of the filter
2. the flow direction (IN -> OUT) is held
3. the connection pipes are fitted tensionless
4. the dismantling dimension and the accessibility of the service elements is guaranteed

Filters with electrical respectively electronic clogging indicators have to be installed according to the unit specific conditions and the technical parameters of the corresponding data sheets.

3. Commissioning

Before commissioning the completeness of the filter (filter elements and seals) and the cleanness have to be controlled. Air bleeding of the controlled filter has to be carried out according to the following instructions:

1. Bring the switching lever of the changeover device into the middle position
2. Connection of high pressure hoses M16 according to data sheet 1650 at the
 - connections III and IV with HDD30, HDD170-450, HDD/EHD 601-1351
 - connections V and VI with MDD40-100, HDD/EHD61-151, EHD241-451, HDN(L)40-100if they are equipped with screw couplings, or connection of suitable ventilation lines to the thread G ¼" (BSPP ¼") of the above connections after unscrewing the screw plugs
3. Provision of a collecting container for the escaping medium
4. Switch on the unit volume flow (flow as low as possible 10-50 l/min (2.6 to 13 gal/min)) until bubble-free operating fluid emerges from both air bleeding lines
5. Switch off of the unit volume flow
6. Remove the air bleeding lines and close the air bleed holes or connections
7. Switch on the desired filter side on the changeover device

The switch lever of the changeover device shows always in direction to the operating filter side.

In the case of paralleling filters, the venting must be carried out simultaneously on all filters during initial commissioning.

4. Change of element

The changing of the filter elements is necessary when reaching the unit specific pressure difference respectively reaching the maximum pressure difference given by the clogging indicator. Should is no unit specific definition, the change of the elements should be done at a maximum of Δp 6 bar (87 PSI).

This has to be carried out as follows:

1. Opening of the pressure balance valve
2. Switch the switching lever of the switching device from the filter side to be serviced to the opposite filter side
3. Closing the pressure balance valve
4. On the filter side to be serviced is the
 - connection III or IV at HDD30, HDD170-450, HDD/EHD 601-1351
 - connection V or VI at MDD40-100, HDD/EHD61-151, EHD241-451, HDN(L)40-100can be opened by connecting a high-pressure hose M16 according to data sheet 1650 or, if screw couplings are not available, connected with a suitable ventilation line. A container for collecting the escaping operating medium must be provided
5. Should an air-bleed screw be present on the filter housing, or on the closing cap of the filter tube, open this and let out the operating medium
6. Unscrew the filter bowl or the closing cap of the filter tube
7. Remove the filter elements
8. Cleaning the filter bowl and the closing cap
9. Replace the new or the cleaned filter elements
10. Screwed the filter bowl or filter tube end cap on and tighten it.

For stainless steel filters of the series EHD the following must be observed:

- Before assembling the filter bowl/tube, apply anti-seize lubricant to bowl threads (Part-No. 355135)!

Tightening torques:

NG 30	NG 40-150 / NG 61-151	NG 170/171-450/451	NG 601-1351
70 Nm [52 lb.-ft.]	80 Nm [59 lb.-ft.]	120 Nm [89 lb.-ft.]	140 Nm [103 lb.-ft.]

11. Closing a possible existing drain hole
12. Air bleeding of the serviced filter side (see item 5)

Now, the serviced filter side is ready for operation.

In general take care of the absolute cleanness during the changing of elements. No dirt respectively no impurities should penetrate the filter. The new elements should be taken out of their packing shortly before they are replaced in the filter housings because of mechanical damage.

During the changing of the elements control the availability and quality of the seals. Damaged seals have to be replaced by new ones.

As a matter of principle the elements in filter batteries have to be changed in all operating filters in a single operation. In the first instance all single filter have to be changed over to the opposite side. The next steps are the same as above.

For stainless steel filters it is recommended to grease all threads with metal sliding grease before reassembly them.

5. Air bleeding the filter

The air bleeding of the filter when changing the element, in contrast to the air bleeding during commissioning, is only carried out on the filter side to be serviced. The air bleeding takes place while the system is operating.

1. On the serviced and not operated filter is the
 - connection III or IV at HDD30, HDD170-450, HDD/EHD 601-1351
 - connection V or VI at MDD40-100, HDD/EHD61-151, EHD241-451, HDN(L)40-100can be opened by connecting with a high-pressure hose M16 or with another suitable line.
2. Open the pressure balance valve until bubble-free fluid emerges from the high pressure hose, or attached line
Repeat the procedure for filters HDD 601-1351, HDNL 401 and their corresponding filter banks, since these filters must be bled of air on the dirt side (connection III) as well as on the clean side (connection IV)
3. After removing the air-bleed line close the pressure balance valve

The serviced filter side is now air-bleeded and is ready for operation without air inside the unit.

In the case of paralleling filters the air bleeding has to be done as described above in on step for the whole filters.

6. Cleaning for the filter element

Filter elements with filter materials such as glass fibre (VG) or paper (P) are not cleanable. They have to be replaced after the dirt retention capacity has been reached. Filter elements with filter material such as wire mesh (G) are cleanable and could be used again.

The cleaning of the filter elements has to be done according to the cleaning specification for Eaton-Filter elements (metal), sheet-no. 21070-4 and 39448-4.

7. Pressure difference measuring

In case of filters installed with clogging indicators a permanent measuring of the pressure difference takes place. The indication corresponds to the kind of clogging indicators; either visual or visual-electrical respectively electronic.

Additionally the connections III and IV could be installed on the selector shaft to be used for external pressure gauges.

At paralleling filters there are additional measuring connections „IN“ and „OUT“ at the connecting block for measuring the pressure difference of the whole paralleling filters.

8. Change the sealing elements

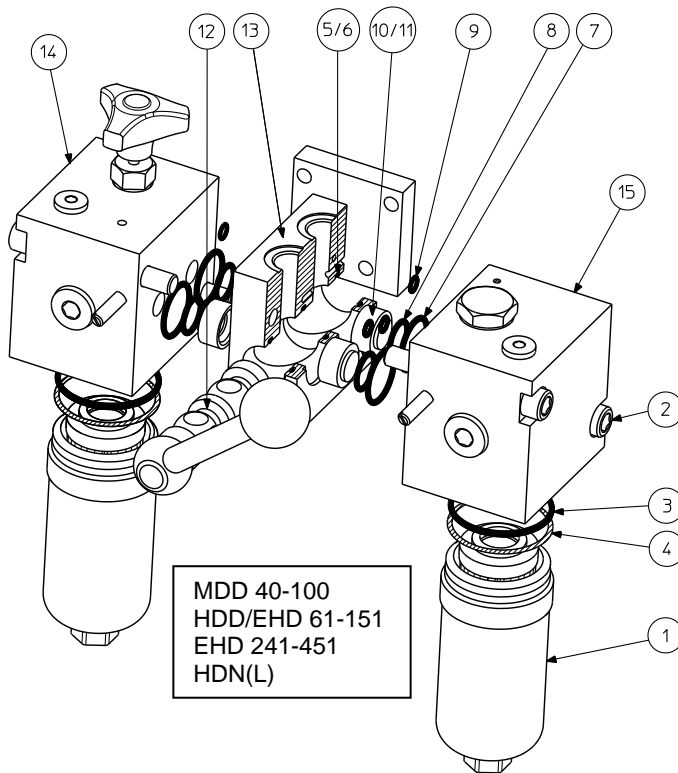

1. Disassemble the filter bowl (item 1).
O-ring (item 3) and support ring (item 4) remove and replace.
Assemble the filter bowl again.
Tightening torques:
NG 40-151 = 80 Nm (59 lb.-ft.)
NG 170-450 = 120 Nm (89 lb.-ft.)
NG 171-451 = 120 Nm (89 lb.-ft.)
2. Loosen the screws (item 2) and remove the left and the right filter part (items 14 and 15).
3. Remove and replace 4x O-ring (item 7 and 8) as well as bushing and sealing ring (item 10 and 11).
Make sure that the replaced O-rings (item 9, 4 pieces) be assembled again.
4. Remove the shaft (item 12) from the switching housing (item 13).
Remove and replace 3x O-ring (item 5) and 2x support ring (item 6).
(There are no support rings on the MDD series)
Insert the shaft in the switching housing.
5. Insert the bushing and sealing ring (items 10 and 11).
Insert the replaced O-rings (items 7, 8 and 9).
6. Assemble left and right filtertop (items 14 and 15) and tighten the screws.
Tightening torques:
M12 = 60-65 Nm (44 to 48 lb.-ft.)
M16 = 160 Nm (118 lb.-ft.)
M20 = 190 Nm (140 lb.-ft.)

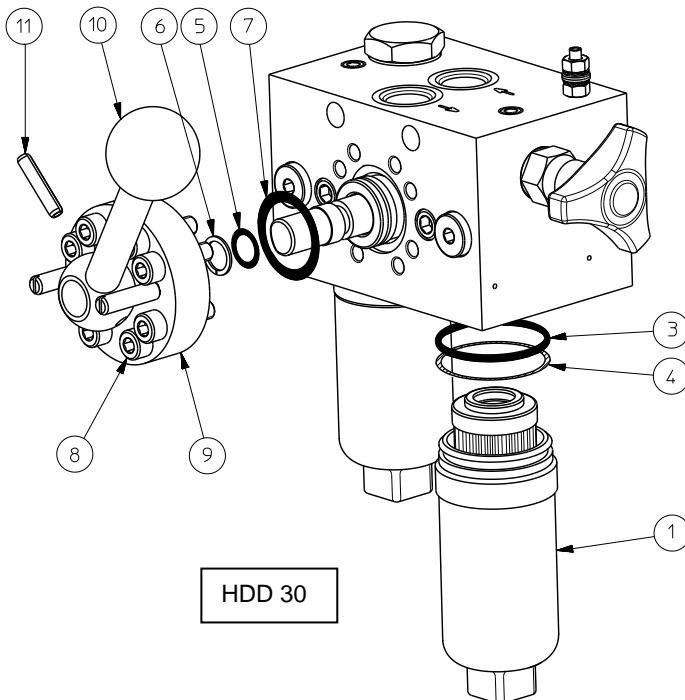

1. Disassemble the filter bowl (item 1).
O-ring 40x3 (item 3) and support ring 48x2.6x1 (item 4) remove and replace.
Assemble the filter bowl again.
Tightening torque:
NG 30 = 70 Nm (52 lb.-ft.)
2. Loosen the screws (item 8) and remove the cover (item 9) and the lever (item 10/11).
O-ring 10x3 (item 5) and support ring 17x2.0x1 (item 6) and O-ring 32x3 (item 7) remove and replace.
Assemble the cover and the lever and tighten the screws.
Tightening torque:
M8 = 18-20 Nm (13 to 15 lb.-ft.)

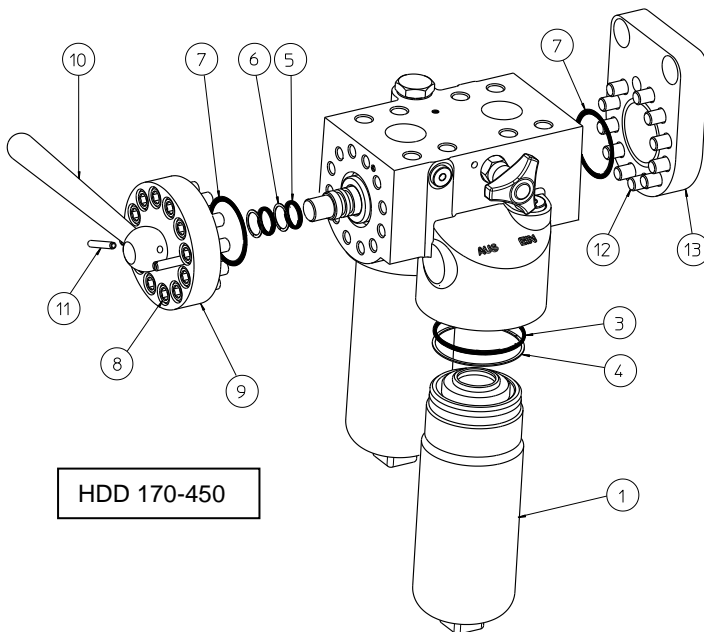

1. Disassemble the filter bowl (item 1).
O-ring 75x3 (item 3) and support ring 81x2.6x1 (item 4) remove and replace.
Assemble the filter bowl again.
Tightening torques:
NG 170-450 = 120 Nm (89 lb.-ft.)
2. Loosen the screws (item 8) and remove the cover (item 9) and the lever (item 10/11).
2x O-ring 18x3 (item 5) and 2x support ring 25x2.5x0.5 (item 6) and O-ring 56x3 (item 7) remove and replace.
Assemble the cover and the lever
Tighten the screws.
Tightening torque:
M12 = 60-65 Nm (44 to 48 lb.-ft.)
3. Loosen the screws (item 12) and remove them the plate (item 13).
Remove and replace O-ring 56x3 (item 7).
Assemble the plate and tighten the screws.
Tightening torque:
M12 = 60-65 Nm (44 to 48 lb.-ft.)

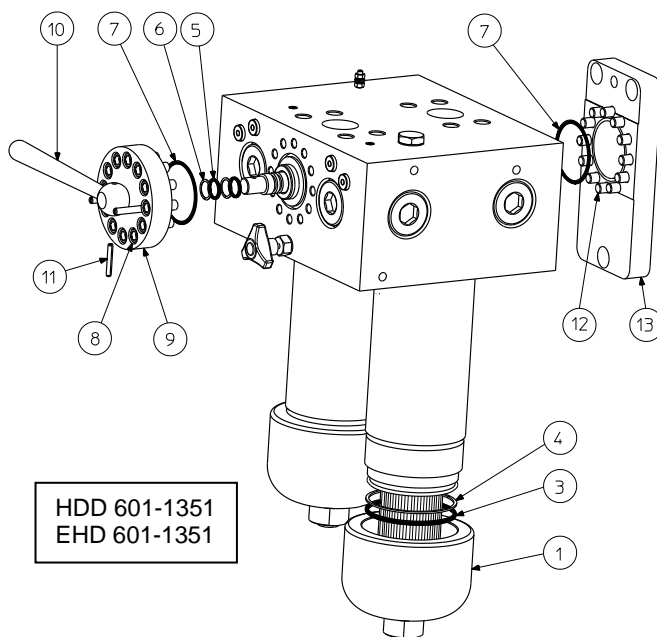

1. Disassemble the filter tube end cap (item 1)
Remove and replace O-ring 98x4 (item 3) and the support ring 110x3.5x2 (item 4).
Assemble and tighten the filter tube end cap.
Tightening torques:
NG 601-1351 = 140 Nm (103 lb.-ft.)
2. Loosen the screws (item 8) and remove the cover (item 9) and the lever (item 10/11).
2x O-ring 18x3 (item 5) and 2x support ring 25x2.5x0.5 (item 6) and O-ring 71x3 (item 7) remove and replace.
Assemble the cover and the lever and tighten screws.
Tightening torque:
M12 = 60-65 Nm (44 to 48 lb.-ft.)
3. Loosen the screws (item 12) and remove them the plate (item 13).
Remove and replace O-ring 71x3 (item 7).
Assemble the plate and tighten the screws.
Tightening torque:
M12 = 60-65 Nm 44 to 48 lb.-ft.)

9. Service

The service will be performed by

EATON Technologies GmbH
Friedensstr. 41
D-68804 Altlußheim
Germany

phone: +49(0)6205-2094-0
fax: +49(0)6205-2094-40

Special questions about the operation of the filter will also be answered within this area.

Spare parts respectively wearing parts have to be ordered according to the spare part list of the filter-data-sheet.