

ELECTRONICAL CLOGGING INDICATOR

Series VS5 (block execution)

Sheet No
1641 C

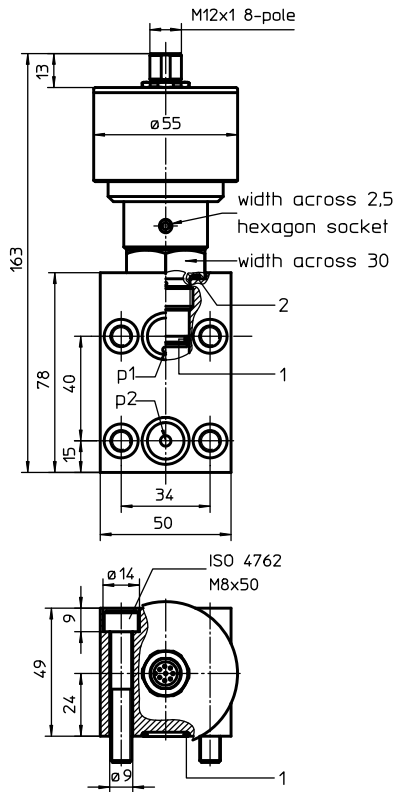

Configuration of M12 connector at VS5

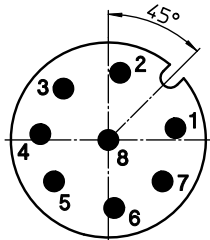

Connection configuration

- 1 GND/0V
- 2 24VDC current supply
- 3 24V PNP at Δp 75%
- 4 24V PNP at Δp 100%
- 5 6...20 mA
- 6 \oplus PE
- 7 reserve not connected
- 8 reserve not connected

3. Spare parts:

item	qty.	designation	dimension	article-no.	
1	3	O-ring	14 x 2	304342 (NBR)	304722 (FPM)
2	1	O-ring	22 x 2	304708 (NBR)	304721 (FPM)

1. Type index: (ordering example)

VS5. 1.5. V. -. NO. CS. B. -

1	2	3	4	5	6	7	8
---	---	---	---	---	---	---	---

1 series:

VS5 = electronical clogging indicator with analog output 6...20mA and 2x PNP-switching contacts (75% and 100%)

2 indicator-pressure difference: Δp -nominal

1,5 = 1,5 bar 5,0 = 5,0 bar
2,5 = 2,5 bar 6,0 = 6,0 bar

3 sealing material:

P = Nitrile (NBR),
V = Viton (FPM)

4 material: (block)

- = standard (aluminium)
VA = stainless steel

5 contact:

NO = normally opened
NC = normally closed

6 cold start:

CS = with cold start suppression up to $25 \pm 3^\circ\text{C}$
- = without cold start suppression

7 execution:

B = block execution

8 connection:

- = without
GS5 = M12, 8-pole female connector
SS5 = M12, 8-pol. female connector with 5m cable and 3 installed LED's red/yellow/green (only in combination with contact "NO = normally opened")

2. Technical data:

- max. operating pressure: 420 bar (stainless steel)
220 bar (aluminium)
- max. pressure difference: 160 bar
- operating temperature: -40°C...+80°C
- temperature range of fluid: -25°C...+100°C (NBR)
-10°C...+100°C (FPM)
- sealing material: other temperature ranges on request
NBR / FPM
further seals on request
- power voltage: +24VDC $\pm 20\%$
- current consumption: approx... 25mA + current signal output (measured with 24VDC)
- output signal: Δp : 6...20mA, max load: 400 Ω
5mA by cold start suppression
75% and 100% from $\Delta p_{\text{nominal}}$ as 24VDC
- error of measurement: $\pm 5\%$ v. $\Delta p_{\text{nominal}}$
- operating ability: < 400mA at closed state
< 1mA at opened state
- protection: IP65 (IP67 on request)
- fatigue strenght: max. 1 Mio load cycles for aluminium

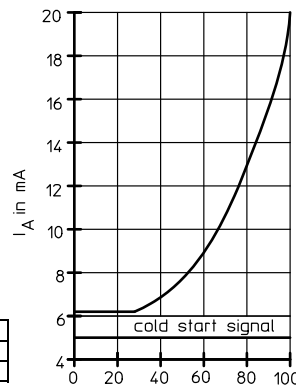

Δp -nominal in %

Changes of measures and design are subject to alteration!

EDV 05/17

4. Functions:

- continuous pressure difference measuring
- cold start indication up to approx. + 25°C
- suppression of pressure peaks
- dust-proof and splash-proof aluminium or stainless steel housing
- interference-free signal transmission over longer distances
- optimal utilization of the filter elements based on a high definition of the measure value within the final measure range
- interchangeable with clogging indicator type AE

5. Connection:

GS5 = M12, 8-pole female connector (article-no. 345742)
temperature range: -40°C ... +80°C

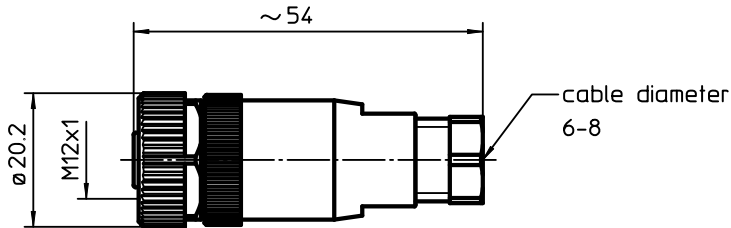

SS5 = M12, 8-pole female connector with 5m cable and 3 installed LED's red/yellow/green (article-no. 347370)
temperature range: -25°C ... +80°C

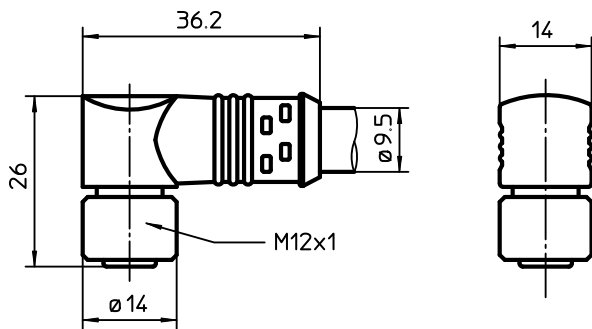

Connection configuration

WH	1	GND/0V
BN	2	24VDC current supply
GN	3	24V PNP at Δp 75%
YE	4	24V PNP at Δp 100%
GY	5	6...20 mA
PK	6	⊕PE
BU	7	reserve not connected
RD	8	reserve not connected

6. Accessories for replacing VS1/VS2 by VS5: (To use the previous connector)

The following adapters are available:

- Article No.: 347425, description: GSA1: for replacing VS1 of executions according to data sheet: 44522 / 60551 / 1617
- Article No.: 350639, description: GSA1-X: for replacing VS1 of executions according to data sheet: 49211 / 44368 / 43477
- Article No.: 347428, description: GSA2: for replacing VS2

