

CLOGGING INDICATOR

Series AOR, AOC (thread execution)

Sheet No.
1606 F

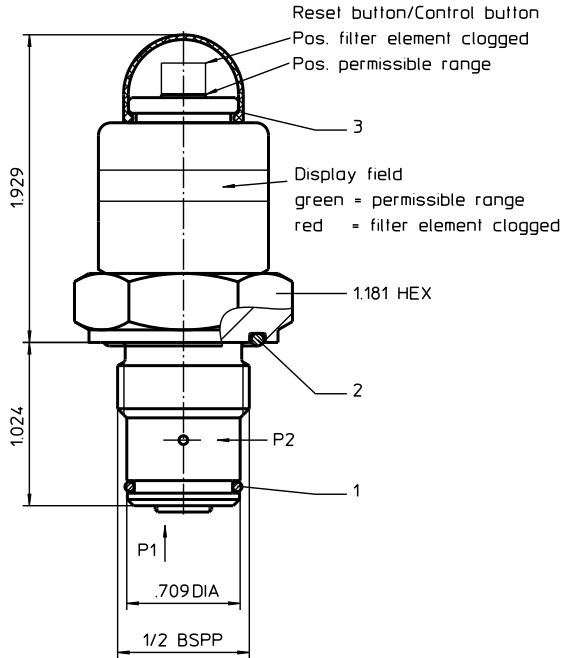

1. Clogging indicator AOR, AOC

1.1. Type index: (ordering example)

AOR. 1,5. P. -

1	2	3	4
---	---	---	---

1 series:

AOR = clogging indicator, visual with reset function
AOC = clogging indicator, visual with control function

2 indicator-pressure difference: Δp -nominal

0,6 = 9 PSI
0,8 = 12 PSI
1,5 = 22 PSI
2,5 = 36 PSI
5,0 = 73 PSI

3 sealing material:

P = Nitrile (NBR)
V = Viton (FPM)

4 material:

- = Standard (aluminium)
VA = stainless steel

2. Technical data:

temperature ranges
- operating temperature: + 14°F to +176°F
(for a short time +212°F)
-22°F to +212°F
- resistant to compression:
- survival temperature: -40°F to +212°F
max. operating pressure: 6000 PSI (stainless steel)
3200 PSI (aluminium)
max. pressure difference: 2320 PSI
reset condition: < 60% Δp -nominal
control condition: < 80% Δp -nominal
max. display error: \pm 10%
fatigue strength: max. 1 Mio load cycles
for aluminium

3. Spare parts:

item	qty.	designation	dimension	article-no.
1	1	O-ring	15 x 1,5	315357 (NBR) 315427 (FPM)
2	1	O-ring	22 x 2	304708 (NBR) 304721 (FPM)
3	1	cap		315325 (PUR)

4. Symbol:

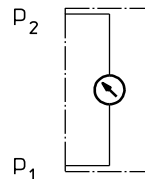

p_1 = measure connection supply
 p_2 = measure connection output

calibrated with oil at 182 SUS

5. Description:

The clogging indicators with designation AOR and AOC are visual pressure difference indicators with a reset function or control function.

These pressure difference indicators can be built on to all pressure filters where ($p \leq 6000$ PSI stainless steel, $p \leq 3200$ PSI aluminium) , and for which a corresponding allocation is provided on the respective dimension sheet. As the filter element becomes increasingly clogged, the difference between the inflow pressure p_1 and the outflow pressure p_2 of the filter will become larger. The display function is triggered at the switching pressure difference: this depends on the pressure difference just mentioned, and is independent of the operating pressure.

A measuring piston which is subject to the inflow and outflow pressure moves against a measuring spring in a manner which depends on the pressure difference. The tractive force between two magnets in the measuring piston and in the display cylinder changes according to the distance moved. At the switching point, the tractive force between the magnets and the force of the spring on the display cylinder are equally large, and are opposed.

In the range $\pm 10\%$ of the set switching pressure, the spring on the display cylinder causes the display cylinder to move suddenly into the „filter element clogged“ display position. This means that the colour in the display field changes from green to red.

In the case of the clogging indicator AOR the display position „filter element clogged“ is fixed, and continues to be maintained even if the pressure difference returns to permissible values, dependent on the viscosity or the rate of flow. The fixed „element clogged“ display position can be canceled by operating the reset button, provided that the reset condition is satisfied.

In the case of the clogging indicator AOC the display position „filter element clogged“ is only fixed in the pressure difference range $\geq 30 \pm 10\%$ of the switching pressure difference. In the range $< 30 \pm 10\%$ of the switching pressure difference occurs a self-instructed shift down to the display position „permissible range“. In the range $> 30\%, < 80\%$ of the switching pressure difference, the display position „filter element clogged“ can be restored for control functions with the control button.

The reset- or control button is located in a position where it is protected from dirt, underneath the elastic cap, item 3, and should be operated with slight manual pressure $< 10\text{N}$.

Note on functional behaviour:

The „filter element clogged“ display will also be triggered if the pressure difference exceeds the switching pressure difference for only a brief period ($> 100\text{ms}$).

The „filter element clogged“ display is triggered in the event of oscillatory or impulse excitations $> 1\text{g}$ at values $< 90\%$ of the switching pressure difference.

6. Operating instructions:

Normally filters are supplied with mounted clogging indicator. When retrofitting - the filter is to be discharged of the operating pressure.

- dismantling the screw plug out of the bare hole which is foreseen for the clogging indicator
 - screw in the clogging indicator into the bare hole (starting torque 74 lb.-ft. stainless steel, starting torque 59 lb.-ft. aluminium)
- It is necessary to make sure the availability and the right positioning of sealing parts
- O-ring 22 x 2 and
 - O-ring 15 x 1,5
- as well as a dirt-free mounting.

7. Maintenance:

This device is maintenance-free; however, care should be taken to ensure that no cleaning agent or solvents reach the transparent hood and the elastic cap over the reset button or control button.