

CLOGGING INDICATOR

Series AE (electrical / visual-electrical, thread execution)

Sheet No.
1615 T

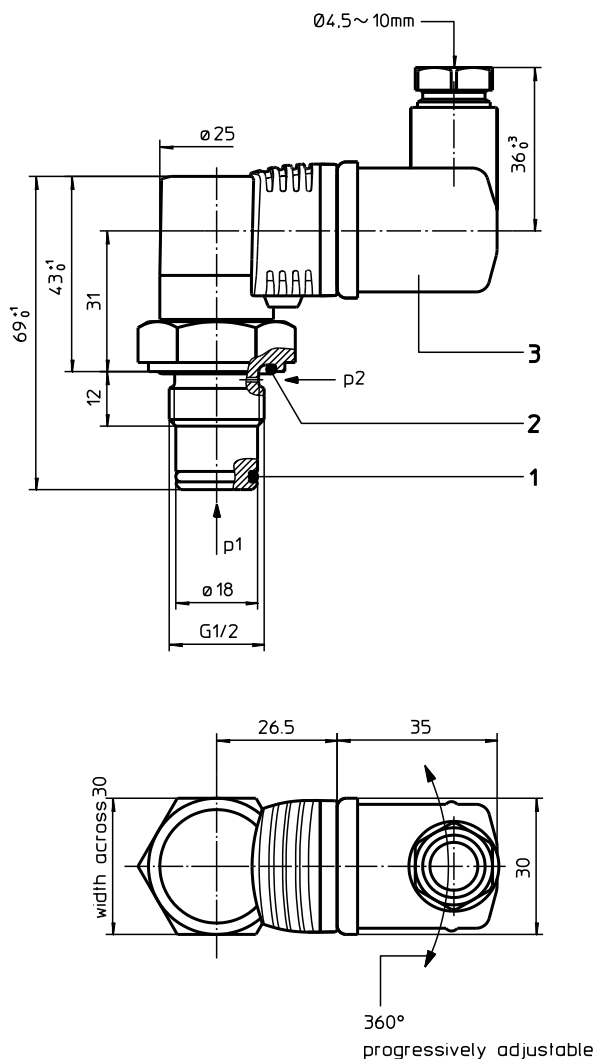

1. Clogging indicator AE

1.1. Type index: (ordering example)

AE. 30. 1,5. P. - . -

1	2	3	4	5	6
---	---	---	---	---	---

- 1 **series:**
AE = clogging indicator, electrical / visual-electrical
- 2 **version:**
30-90 = see table below
- 3 **indicator-pressure difference: Δp -nominal**
0,6 = 0.6 bar
0,8 = 0.8 bar
1,5 = 1.5 bar
2,5 = 2.5 bar
5,0 = 5.0 bar
- 4 **sealing material:**
P = Nitrile (NBR)
V = Viton (FPM)
- 5 **material:**
- = standard (aluminium)
VA = stainless steel
- 6 **execution:**
- = standard

2. Technical data:

temperature ranges	-10°C to +80°C (for a short time +100°C)
- operating temperature:	-30°C to +100°C
- resistant to compression:	-40°C to +100°C
- survival temperature:	420 bar (stainless steel) 220 bar (aluminium)
max. operating pressure:	160 bar
max. pressure difference:	max. 1 Mio load cycles for aluminium
fatigue strength:	

Version	luminous indication	contact	voltage	max. rupturing capacity (resistive load)	max. switching current (resistive load)	connection protection
30	-	contact maker and contact breaker	max. 175V DC max. 125V AC	10 Watt/VA	0.5 A	DIN EN 175301-803-A, ISO 4400
40	-		max. 175V DC max. 230V AC	20 VA 10 Watt	1.0 A 0.5 A	
70	2x LED		24V DC	10 VA	0.4 A with 24V DC	other screw connection on request
80	2x LED		24V DC	20 VA	0.8 A with 24V DC	
90	2x LED		110...230V AC/DC	20 Watt	1.0 A	

calibrated with oil at 40 mm²/s

Dimensions: mm

3. Spare parts:

item	qty.	designation	dimension	article-no.	type
1	1	O-ring	14 x 2	304342 (NBR)	versions 30 - 90
				304722 (FPM)	
2	1	O-ring	22 x 2	304708 (NBR)	
				304721 (FPM)	
3	1	line adapter	DIN EN 175301-803-A, ISO 4400 IP65 acc. to DIN EN 60529 other screw connection on request	312492	versions 30 and 40
	1	line adapter with LED 24V		315012	versions 70 and 80
	1	line adapter with LED 110...230V		354242	version 90

4. Symbols:

hydraulic-electrical symbol

versions 30 and 40

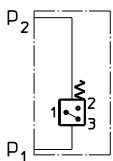

versions 70, 80 and 90

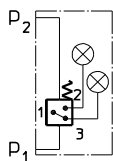

p₁ = measuring connection input
p₂ = measuring connection output

connection configuration for LED

versions 70 und 80

LED 24V, U = +24DC

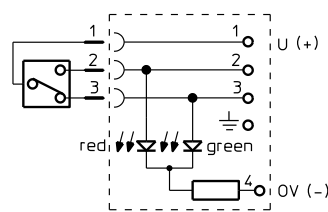

version 90

LED 110...230V, ~

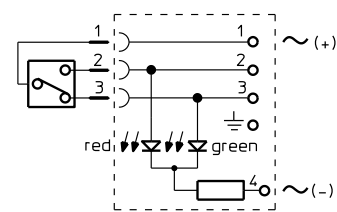

5. Description:

The AE 30 and AE 40 pollution indicators are electrical differential pressure indicators.

The AE 70 to AE 90 pollution indicators are combined optical and electrical differential pressure indicators. These differential pressure indicators can be fitted to all pressure filters ($p \leq 420$ bar stainless steel, $p \leq 220$ bar aluminium) for which there is a corresponding assignment on the relevant dimension drawing. As the degree of pollution of the filter element rises, so the difference between the entry pressure p_1 and the exit pressure p_2 of the filter increases.

Depending on this pressure difference and irrespective of the operating pressure, in the pollution indicators:

- AE 30 and AE 40, two electrical signals (contact maker/contact breaker) are triggered
- AE 70, AE 80 and AE 90, two electrical signals (contact maker/contact breaker) are triggered and two optical signals are formed.

A metering piston subjected to the entry and exit pressure moves against a metering spring according to the pressure differential. Depending on the path a permanent magnet integrated in the metering piston activates a reed contact (electromagnetic switch) and triggers the electrical signal. The electrical and optical indication is effected as a digital signal at the given switching pressure. Versions 70 to 90 of the pollution indicator are fitted with additional LED displays. The optical LED signal becomes visible according to the selected version in the translucent cover plate of the line box on the pollution indicator.

In the pollution indicators:

- AE 70, AE 80 and AE 90, the green LED signals the normal operating state (filter element not yet polluted to an unacceptable level), while the red LED signals that the filter element needs to be changed.

The clogging indicators meet protection class 2 according to DIN EN 61140.

6. Operating instructions:

Normally filters are supplied with mounted clogging indicator. When retrofitting - the filter is to be discharged of the operating pressure.

- dismantling the screw plug out of the bare hole which is foreseen for the clogging indicator
- screw in the clogging indicator into the bare hole (starting torque 100 Nm stainless steel, 80 Nm aluminium)

It is necessary to make sure the availability and the right positioning of sealing parts

- O-ring 22 x 2 and
- O-ring 14 x 2

as well as a dirt-free mounting. The electrical contacts are to be connected according to the graphical symbol shown on the type plate of the clogging indicator.

7. Maintenance:

The device is maintenance-free, however, note that no cleaning fluids and solvents get on the transparent cap of the optical indicator.