

Fluid purifier systems and
oil service equipment



Powering Business Worldwide

Eaton combines sales, engineering, manufacturing, customer service and technical sales support into one focused business provide customers with optimum filtration solutions.

Eaton is continually striving for improvement, with integrity as an underlying business strategy that forms the trademark of all its products and services. Eaton is one of the leading manufacturers of products and solutions for filtration combining measurement, diagnostic and analysis technology, as well as more than 4,000 hydraulic filter elements and corresponding filter housings.

Filtration of cooling, hydraulic and lubricant fluids

- Stationary off-line filter units
US series
- Mobile off-line filter units
UM series
- Mobile off-line fluid cleaning systems
IFPM series



Improve the reliability of the entire system's equipment and prolong fluid service life by reducing solid and water contamination, maintaining lubricity and slowing fluid aging.

Oil service equipment for hydraulic and lubrication systems

An in-line filter is generally sufficient for use in hydraulic and lubrication systems. When filling for the first time, changing the oil, flushing, or for machines with a discontinuous volume flow, Eaton recommends additional off-line filtration.

To ensure optimum operation, flushing must be performed before initial start up in stationary and mobile hydraulic and lubrication systems.

Eaton's oil treatment systems simplify offline filtration and help save costs new oil, maintenance and replacing components.

Features of off-line filter units

- Reliable and simple off-line filtration
- Reinforces existing operating in-line filter
- Improves cleanliness classes
- Longer service life of system components and operating fluids
- Compact design saves space and adapts to your operation
- High-quality filter elements with high dirt holding capacity
- Filter elements can be replaced tools or system downtime
- Safety valves permit unattended operation
- Uninterrupted filtration during tank filling
- Optional use of water-absorbing filter elements

US series stationary off-line filter units

The stationary filter units in the US series are used for the fine filtration, filling or flushing of hydraulic systems. The filter units are equipped with a gear pump driven by an electric motor. They are available for various volume flow rates, in different sizes, and with different micron ratings for the required fluid cleanliness.

The filter units in the USP series have an additional plate heat exchanger to clean and cool the hydraulic or lubricating oils. A number of tests have shown that lowering the temperature by 50 °F (10 °C) doubles the service life of hydraulic oil. Lower oil temperatures also prevent damage resulting from thermal decomposition, such as seal failures and decreases in film thickness on the surfaces of hydraulic components (such as valves and cylinders), which could lead to unscheduled system outages.

UM series mobile offline filter units

The mobile filter units in the UM series combine the convenience of the US filter units with mobile oil treatment in hydraulic and lubrication systems.

The filter units in the UMP series have a pneumatic double diaphragm pump instead of an electronic gear pump, and are suitable for explosion proof applications (Ex II 2 G/D c IIA T5).

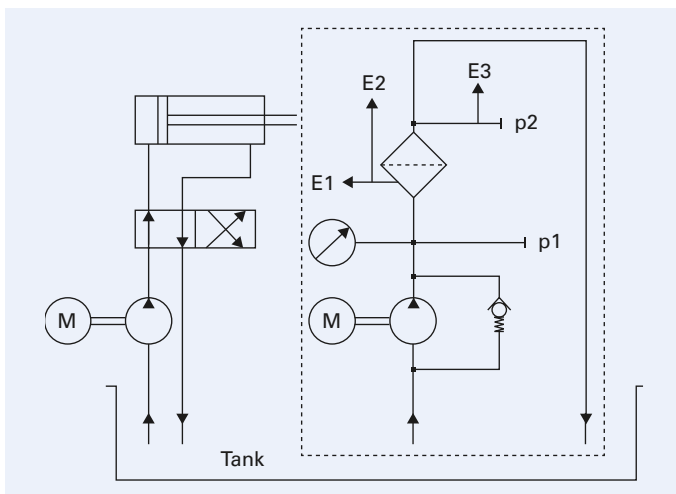

During off-line filtration, the filter operates in a cycle that is separate from the main system. By separating the systems, off-line filtration can take place independently of the system's running time until the desired fluid cleanliness is reached.



UM 80



US 160

Removal of water, gases and solid contaminants using fully automated compact systems.

Eaton fluid purifier systems remove free, emulsified and dissolved water, free and dissolved gases, and solid contaminants. They have been developed for different viscosity ranges, from transformer to heavy gear lubricating oils. The selection of the micron rating used depends on the required fluid purity. The mobile fluid cleaning systems in the IFPM series are available in two standard sizes with flow rates of 7.9 gal/min (30 l/min) and 18.5 gal/min (70 l/min).

Effects of water contamination

Water is one of the most frequently occurring contaminants and is second only to particulate contamination as a destructive foreign substance in a system. Some of the problems and damage water contamination can cause include:

- Shortened service life of the fluid
- Reduced performance of the lubricating fluid
- Heavy wear to the components
- Loss of polarizing additives
- Rust
- Increased conductivity

IFPM fluid cleaning system technology

Vacuum evaporation with inert gas is the most effective water removal method for fluid cleaning systems. This method combines high water separation rates with an efficient use of energy, and allows the drying process to take place even below the saturation point of the prepared fluid. By contrast, conventional vacuum evaporation only brings the water content of the fluid to the same level as that of the water vapor in the surrounding atmosphere.

The IFPM fluid purifier systems are fully automated, PLC-controlled compact enough for use in confined areas. The WSPS 05 sensor permanently monitors the water saturation in a purified fluid. A ventilation filter with silica gel dries the inflowing air, increasing the efficiency of the cleaning system even in environments with high humidity levels. The VS5 electronic contamination sensor provides the optimal use and maintenance scheduling of the particle removal filter element.

Operating principle

- The contaminated fluid is drawn into the fluid cleaning system using a vacuum
- The fluid passes a heater, which raises the temperature in order to increase the water removal process
- Fluid reaches the vacuum chamber through a two-port magnetic valve
- The dispersion material in the vacuum chamber increases the fluid's evaporation surface area
- The vacuum decreases the water evaporation temperature, converting free water and water dissolved in the fluid into steam
- Ambient air enters through a ventilation filter and passes through the fluid against the direction of flow, acting as a carrier medium for the steam produced
- The humid air enters a vacuum pump and released into the atmosphere using an oil mist separator



IFPM 32



Web-enabled control unit with touch panel and USB interface



Factors affecting system efficiency

The processing time required to reach an acceptable water content level is primarily dependent on the fluid type. Other factors affecting the speed of the drying process are listed in the following table.

Parameter	Water removal rate
Temperature:	Greatly increased
Vacuum:	Increased
Initial water content:	Increased
Additives:	Reduced
Flow rates:	Increased

Chart of water content over time for various fluids

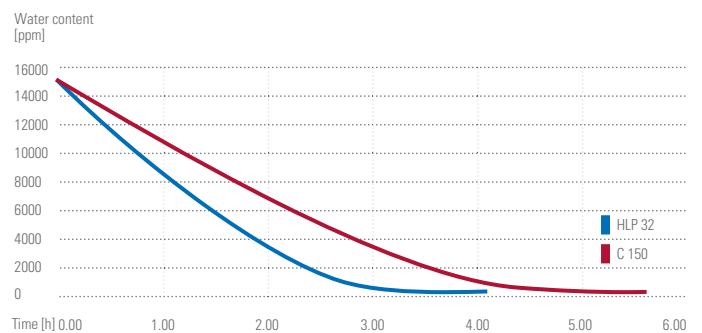

Technical Data	IFPM 32	IFPM 72
Operating parameters:		
Power supply options:	380 to 415 V AC/50/60 Hz/9.4 A/5.1 kW or 440 to 480 V AC/60 Hz/9.1 A/5.4 kW	380 to 415 V AC/50/60 Hz/17.9 A/10.8 kW or 440 to 480 V AC/60 Hz/15.7 A/10.6 kW
Protection class:	IP 54	IP 54
Max. intake pressure:	≤ 2.9 psi (≤ 0.2 bar)	≤ 2.9 psi (≤ 0.2 bar)
Viscosity:	55 to 3220 SUS (12 to 700 mm ² /s)	55 to 3220 SUS (12 to 700 mm ² /s)
Fluid temperature:	50 °F to 176 °F (10 to 80 °C)	50 °F to 176 °F (10 to 80 °C)
Ambient temperature:	32 °F to 104 °F (0 to 40 °C)	32 °F to 104 °F (0 to 40 °C)
Intake connector:	SAE flange 1½" (3.81 cm)	SAE flange 1½" (3.81 cm)
Outlet connector:	SAE flange 1¼" (3.175 cm)	SAE flange 1¼" (3.175 cm)
Volume flow*:	7.5 gal/min (28.5 l/min)	18.6 gal/min (70.3 l/min)
Water removal rate**:	5.8 gal/day (22 l/day)	14.3 gal/day (54 l/day)
Measurement parameters:		
Water saturation:	0 to 100%	0 to 100%
Temperature:	-13 to 212 °F (-25 to 100 °C)	-13 to 212 °F (-25 to 100 °C)
Pressure (vacuum chamber):	14.5 to 0 psi (1 to 0 bar) (relative)	14.5 to 0 psi (1 to 0 bar) (relative)
Filter contamination:	50 to 100%	50 to 100%

* With a fluid viscosity of 147 SUS (32 mm²/s) ** Free water at 140 °F (60 °C) and 147 SUS (32 mm²/s)

FLUID MANAGEMENT PRODUCTS

Off-line filter units

Stationary

US 10
US 16
US 20
US 21
US 22
US 40
US 80
US 160
US 320
US 321
US 640
US 960

Mobile

UM 20
UM 40
UM 80
UM 125
UFM 15

With pneumatic double
diaphragm pumps:
UMP 20
UMP 40

Off-line fluid cleaning systems

Mobile

IFPM 32
IFPM 72

With plate heat exchangers:

USP 20
USP 41
USP 81
USP 161
USP 320

North America
44 Apple Street
Tinton Falls, NJ 07724
Toll Free: 800 656-3344
(North America only)
Tel: +1 732 212-4700

Europe/Africa/Middle East
Auf der Heide 2
53947 Nettersheim, Germany
Tel: +49 2486 809-0

Friedensstraße 41
68804 Altlufheim, Germany
Tel: +49 6205 2094-0

An den Nahewiesen 24
55450 Langenlonsheim, Germany
Tel: +49 6704 204-0

China
No. 3, Lane 280,
Linhong Road
Changning District, 200335
Shanghai, P.R. China
Tel: +86 21 5200-0099

Singapore
100G Pasir Panjang Road #07-08
Singapore 118523
Tel: +65 6825-1668

Brazil
Rua Clark, 2061 - Macuco
13279-400 - Valinhos, Brazil
Tel: +55 11 3616-8400

**For more information, please
email us at filtration@eaton.com
or visit www.eaton.com/filtration**

© 2018 Eaton. All rights reserved. All trademarks and registered trademarks are the property of their respective owners. All information and recommendations appearing in this brochure concerning the use of products described herein are based on tests believed to be reliable. However, it is the user's responsibility to determine the suitability for his own use of such products. Since the actual use by others is beyond our control, no guarantee, expressed or implied, is made by Eaton as to the effects of such use or the results to be obtained. Eaton assumes no liability arising out of the use by others of such products. Nor is the information herein to be construed as absolutely complete, since additional information may be necessary or desirable when particular or exceptional conditions or circumstances exist or because of applicable laws or government regulations.

US
EFINHDL-EU
10-2018



Powering Business Worldwide

