

NOZZLE SCHEDULE		ITEM	QTY.	NAME	DESCRIPTION
N1	1	INLET	4" - 150#	RFSO ASME B16.5	
N2	1	OUTLET	4" - 150#	RFSO ASME B16.5	
N3	1	DRAIN	1-1/2" NPT	3000# COUPLING	
N4	1	VENT	1/2" NPT	3000# COUPLING	
N5	2	WATER GAGE	1/2" NPT	3000# COUPLING	
N6	2	LIQUID LEVEL	1" NPT	3000# COUPLING	

REV	DATE	CHANGE	ECR	BY	APP
A	6/29/06	NEW ISSUE	E050	FM	FM

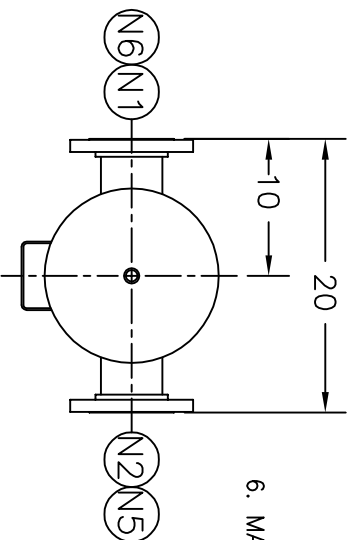
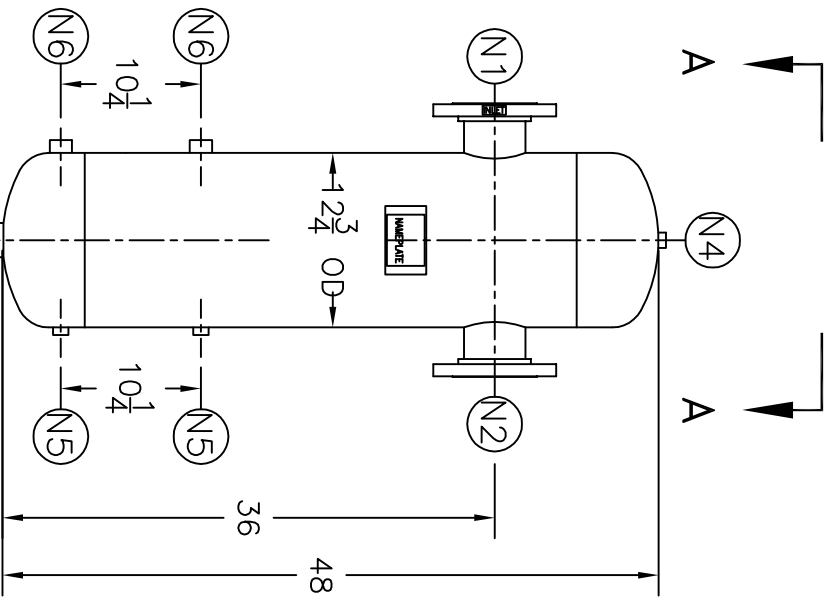

VIEW A-A
TRUE ORIENTATION

ELECTRONIC FILE NAME:
SD4TS150C.DWG

TOLERANCES UNLESS OTHERWISE SPECIFIED
PER ENGINEERING STANDARD ES- - -

UNAUTHORIZED USE, MANUFACTURE OR
REPRODUCTION IN WHOLE OR IN PART IS
PROHIBITED. DRAWING, DESIGN AND
OTHER DISCLOSURES PROPERTY OF
EATON FILTRATION, LLC

NOTES:

- UNITS ARE TO BE DESIGNED, FABRICATED, AND CODE STAMPED (IF REQUIRED) IN ACCORDANCE WITH ASME B & PV CODE, SECTION VIII, DIVISION 1 IN COMPLIANCE TO CURRENT PUBLISHED ADDENDA.
- ALL DIMENSIONS ARE IN INCHES.
- ALL BOLT HOLES ARE TO STRADDLE NATURAL CENTERLINES.
- SHIPPING WEIGHT: 175 POUNDS.
- DESIGN DATA:

- | | |
|--------------------------|-------------------|
| DESIGN PRESSURE- | 150 PSIG |
| DESIGN TEMPERATURE- | 450° F |
| MIN. DESIGN METAL TEMP.- | -20° F @ 150 PSIG |
| HYDROTEST PRESSURE- | 225 PSIG |
| CORROSION ALLOWANCE- | 0 INCHES |
| 6. MATERIAL: | CARBON STEEL |

CUSTOMER:
REG. NO.:
P.O. NO.:
TAG NO.:
HAYWARD PART NO.: 4TS150C, 4TS150CU & 4TS150CM

		EATON FILTRATION, LLC 900 FAIRMOUNT AVENUE, ELIZABETH, NEW JERSEY 07207	
		4" TYPE "TS" GAS/LIQUID SEPARATOR 150# FLG CSTL	
DRAWN	FM	DATE	6/29/06
APP	FJM	DATE	6/29/06

SIZE	DWG NO	REV
A		A

SD4TS150C