

NOZZLE SCHEDULE		
ITEM	QTY.	NAME DESCRIPTION
N1	1	3"-150# RFSO ASME B16.5
N2	1	3"-150# RFSO ASME B16.5
N3	1	1-1/2" NPT 3000# COUPLING
N4	1	1/2" NPT 3000# COUPLING
N5	2	W.G. CONNECTIONS 1/2" NPT 3000# COUPLING
N6	2	LIQUID LEVEL 1" NPT 3000# COUPLING

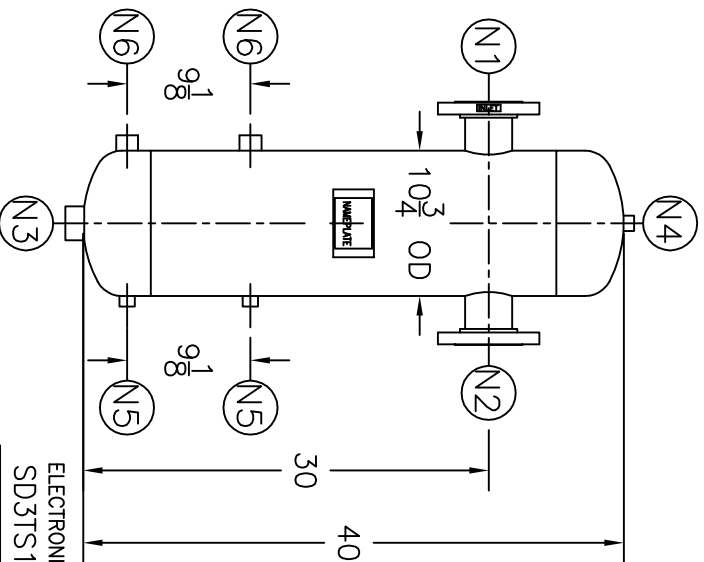
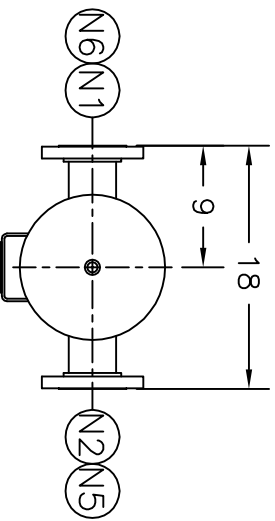

REV	DATE	CHANGE	ECR	BY	APP
A	10/08/98	NEW ISSUE	6775	AB	DP
B	11/4/03	HYDROTEST PRESS. WAS 246 PSI	8829	FM	FJM
C	11/1/05	REVISED TITLE BLOCK	D507	FM	LH

NOTES:

- UNITS ARE TO BE DESIGNED, FABRICATED, AND CODE STAMPED (IF REQUIRED) IN ACCORDANCE WITH ASME B & PV CODE, SECTION VIII, DIVISION 1 IN COMPLIANCE TO CURRENT PUBLISHED ADDENDA.
- ALL DIMENSIONS ARE IN INCHES.
- ALL BOLT HOLES ARE TO STRADDLE NATURAL CENTERLINES.
- SHIPPING WEIGHT: 110 POUNDS.
- DESIGN DATA:
 DESIGN PRESSURE- 150 PSIG
 DESIGN TEMPERATURE- 300° F
 MIN. DESIGN METAL TEMP.- -20° F @ 150 PSIG
 HYDROTEST PRESSURE- 195 PSIG
 CORROSION ALLOWANCE- 0 INCHES
- MATERIAL: 304L STAINLESS STEEL.

CUSTOMER:
 REG. NO.:
 P.O. NO.:
 TAG NO.:
 PART NO.: JTS150S

EATON FILTRATION, LLC
 900 FAIRMOUNT AVENUE, ELIZABETH, NEW JERSEY 07207
 NAME
3" TYPE "TS" GAS/LIQUID
SEPARATOR 150# FLG 304L SSTL



ELECTRONIC FILE NAME:
 SD3TS15S.DWG
 TOLERANCES UNLESS OTHERWISE SPECIFIED
 PER ENGINEERING STANDARD ES- ---

UNAUTHORIZED USE, MANUFACTURE OR
 REPRODUCTION IN WHOLE OR IN PART IS
 PROHIBITED. DRAWING, DESIGN AND
 OTHER DISCLOSURES PROPERTY OF
 EATON FILTRATION, LLC

DRAWN	AB	DATE	10/07/98	CHECKED	DP	DATE	10/07/98	
APP	---	DATE	---	SCALE	NTS	ECR	6775	
SIZE	DWG	NO						
A								
SD3TS150S							REV	C