

DIMENSION TABLE						PART NO.
PIPE SIZE	A	B	C	D	WGT	
1 1/2	11.50	24.00	9.13	9.13	106	1.5TS150S6/U/M

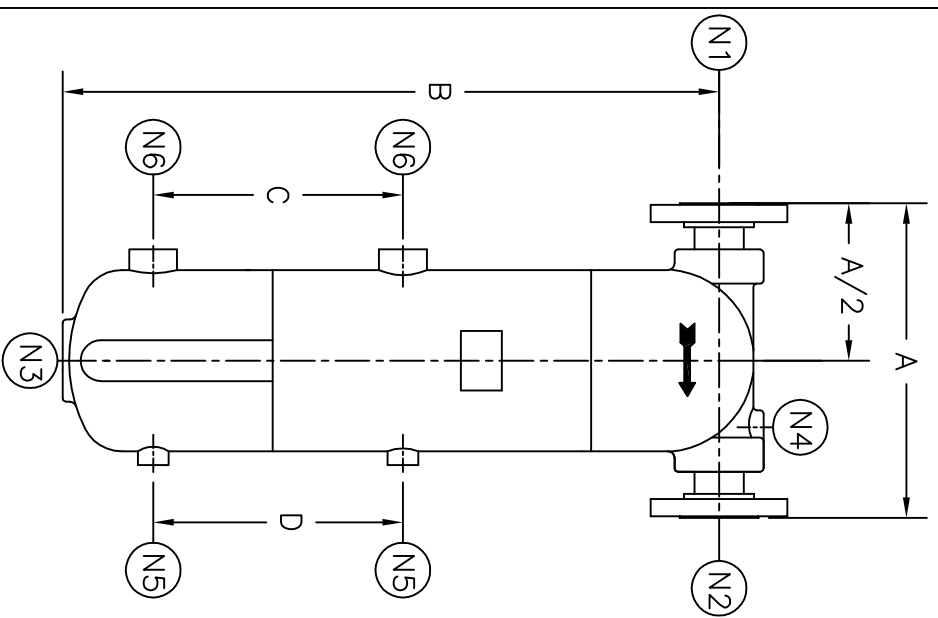

ITEM	DESCRIPTION	NAME	QTY.
N1	1-1/2" STD. WGT. PIPE	INLET	1
N2	1-1/2" STD. WGT. PIPE	OUTLET	1
N3	1" NPT	DRAIN	1
N4	1/4" NPT	VENT	1
N5	1/2" NPT 3000# CPLG	WATER GAGE	2
N6	1" NPT 3000# CPLG	LIQUID LEVEL	2

REV	DATE	CHANGE	ECR	BY	APP
A	08/03/06	NEW RELEASE	E119	LH	FJM

NOTES:

1. UNITS ARE TO BE DESIGNED, FABRICATED, AND "U" OR "UM" STAMPED (IF REQ'D) IN ACCORDANCE WITH ASME B & PV CODE, SECTION VIII, DIVISION 1 IN COMPLIANCE TO CURRENT PUBLISHED ADDENDA.
2. ALL DIMENSIONS ARE IN INCHES.
3. SHIPPING WEIGHT: SEE DIMENSION TABLE
4. DESIGN DATA:
 - DESIGN PRESSURE- 150 PSIG
 - DESIGN TEMPERATURE- 300° F
 - MIN. DESIGN METAL TEMP.- -20° F @ 150 PSIG
 - HYDROTEST PRESSURE- 195 PSIG
 - CORROSION ALLOWANCE- 0 INCHES
5. MATERIAL: 316 STAINLESS STEEL.

CUSTOMER:
 REG. NO.:
 P.O. NO.:
 TAG NO.:

ELECTRONIC FILE NAME:
 1.5TS150S6.DWG
 TOLERANCES UNLESS OTHERWISE SPECIFIED
 PER ENGINEERING STANDARD ES- --
 UNAUTHORIZED USE, MANUFACTURE OR
 REPRODUCTION IN WHOLE OR IN PART IS
 PROHIBITED. DRAWING, DESIGN AND
 OTHER DISCLOSURES PROPERTY OF
 EATON FILTRATION, LLC

		EATON FILTRATION, LLC 900 FAIRMOUNT AVENUE, ELIZABETH, NEW JERSEY 07207					
		NAME 1-1/2" TYPE "TS" GAS/LIQUID SEPARATOR 150# FLG, CAST S.ST					
DRAWN	LH	DATE	8/02/06	CHECKED	FM	DATE	8/03/06
APP	FJM	DATE	08/03/06	SCALE	NTS	ECR	E119
SIZE	A	DWG NO				REV	A
		SD1.5TS150S6					