

NOZZLE SCHEDULE	
ITEM QTY.	NAME DESCRIPTION
N1 1	3" ANSI CLASS 600 RF SO ASME B16.5
N2 1	3" ANSI CLASS 600 RF SO ASME B16.5
N3 1	1-1/2" ANSI CLASS 3000 NPT COUPLING
N4 1	1/4" ANSI CLASS 3000 NPT COUPLING
N5 2	LIQUID LEVEL 1/2" ANSI CLASS 3000 NPT COUPLING

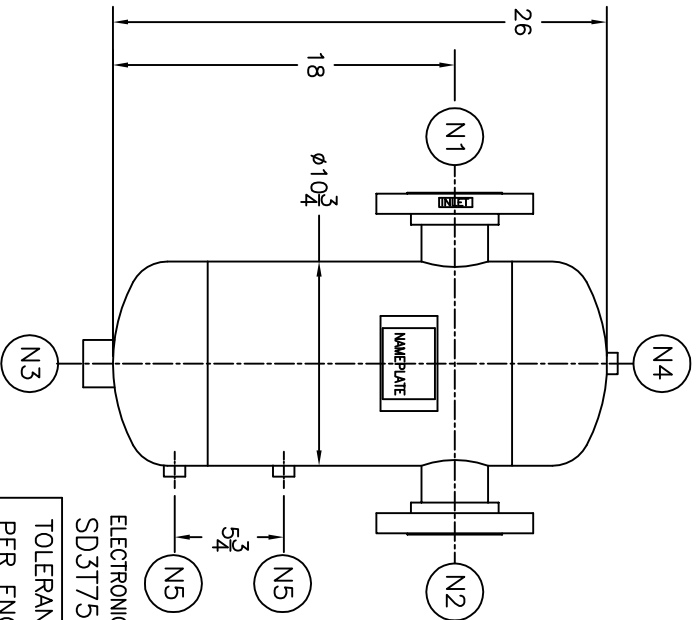
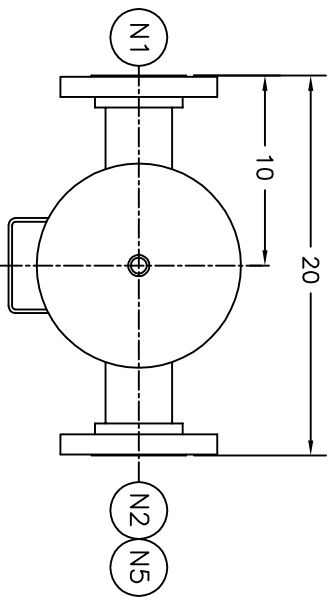

REV	DATE	CHANGE	ECR	BY	APP
A	11/18/02	NEW ISSUE	B035	VA	LH
B	11/1/05	REVISED TITLE BLOCK	D507	FM	LH

NOTES:

1. UNITS ARE TO BE DESIGNED, FABRICATED AND "U" STAMPED IN ACCORDANCE WITH ASME BOILER & PRESSURE VESSEL CODE, SECTION VIII, DIVISION 1 IN COMPLIANCE TO CURRENT PUBLISHED ADDENDA.
2. ALL DIMENSIONS ARE IN INCHES.
3. ALL BOLT HOLES ARE TO STRADDLE NATURAL CENTERLINES.
4. SHIPPING WEIGHT: 190 POUNDS.
5. DESIGN DATA:
 DESIGN PRESSURE- 750 PSIG
 DESIGN TEMPERATURE- 650° F
 MIN. DESIGN METAL TEMP.- -20° F @ 750 PSIG
 HYDROTEST PRESSURE- 975 PSIG
 CORROSION ALLOWANCE- 0 INCHES
6. MATERIAL: CARBON STEEL.

STANDARD

CUSTOMER:
 REG. NO.:
 P.O. NO.:
 TAG NO.:
 PART NO.: 3T750CU



EATON FILTRATION, LLC
 900 FAIRMOUNT AVENUE, ELIZABETH, NEW JERSEY 07207
 NAME: 3" TYPE "T" GAS/LIQUID SEPARATOR
 600# RF FLANGED - CARBON STEEL

ELECTRONIC FILE NAME:
 SD3T750CU

TOLERANCES UNLESS OTHERWISE SPECIFIED
 PER ENGINEERING STANDARD ES- --

UNAUTHORIZED USE, MANUFACTURE OR
 REPRODUCTION IN WHOLE OR IN PART IS
 PROHIBITED. DRAWING, DESIGN AND
 OTHER DISCLOSURES PROPERTY OF
 EATON FILTRATION, LLC

DRAWN	VA	CHECKED	FM	DATE	11/18/02	DATE	11/18/02	
APP	LH	SCALE	NTS	DATE	11/18/02	EGR	A033	
SIZE	DWG	SD3T750CU						REV
A	NO							B