

NOZZLE SCHEDULE		
ITEM	QTY.	NAME DESCRIPTION
N1	1	8" - 150# RFSQ, B16.5
N2	1	8" - 150# RFSQ, B16.5
N3	1	2" - NPT 3000# COUPLING
N4	1	1/2" - NPT 3000# COUPLING
N5	2	1/2" - NPT 3000# COUPLING

REV	DATE	CHANGE	ECR	BY	APP
A	08/01/02	NEW ISSUE	A741	LH	VA
B	09/11/02	DELETED 817R200SM	A853	FM	LH
C	11/1/05	REVISED TITLE BLOCK	D507	FM	LH

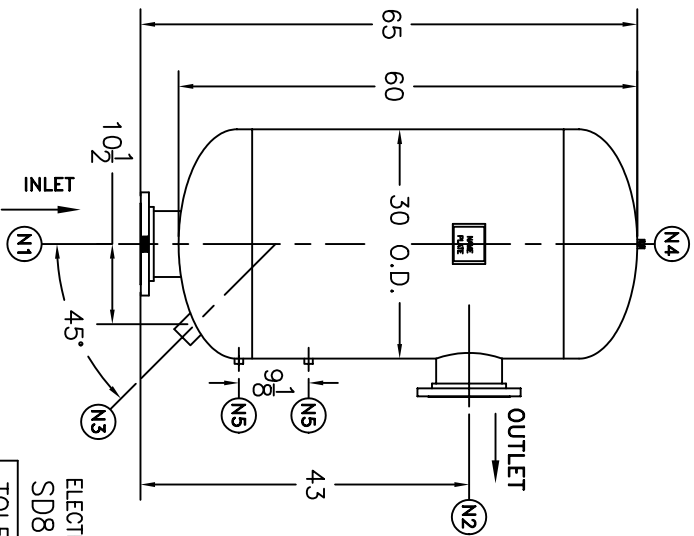
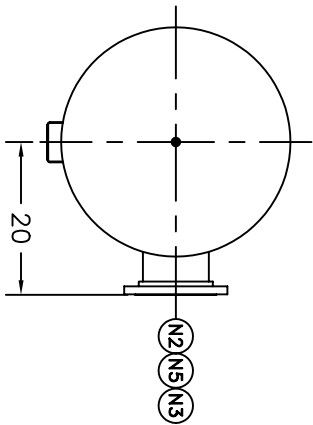

NOTES:

- UNITS ARE TO BE DESIGNED, FABRICATED, AND "U" STAMPED (IF REQUIRED) IN ACCORDANCE WITH ASME B & PV CODE, SECTION VIII, DIVISION 1 IN COMPLIANCE TO CURRENT PUBLISHED ADDENDA.
- ALL DIMENSIONS ARE IN INCHES.
- ALL BOLT HOLES ARE TO STRADDLE NATURAL CENTERLINES.
- SHIPPING WEIGHT: 650 POUNDS.
- DESIGN DATA:

DESIGN PRESSURE-	200 PSIG
DESIGN TEMPERATURE-	300° F
MIN. DESIGN METAL TEMP.-	-20° F @ 200 PSIG
HYDROTEST PRESSURE-	275 PSIG
CORROSION ALLOWANCE-	0 INCHES
- MATERIAL: 304 STAINLESS STEEL

CUSTOMER:
REG. NO.:
P.O. NO.:
TAG NO.:

PART NO.: 817R200S, 817R200SU

ELECTRONIC FILE NAME:
SD817R200S.DWG
TOLERANCES UNLESS OTHERWISE SPECIFIED
PER ENGINEERING STANDARD ES- --

UNAUTHORIZED USE, MANUFACTURE OR
REPRODUCTION IN WHOLE OR IN PART IS
PROHIBITED. DRAWING, DESIGN AND
OTHER DISCLOSURES PROPERTY OF
EATON FILTRATION, LLC

EATON	EATON FILTRATION, LLC	
	900 FAIRMOUNT AVENUE, ELIZABETH, NEW JERSEY 07207	
NAME	8" TYPE "17-R" GAS/LIQUID SEPARATOR 150# FLG. 304 S.STL.	

DRAWN	LH	DATE	07/31/02	CHECKED	FM	DATE	08/02/02
APP	VA	DATE	08/02/02	SCALE	NTS	ECR	A741
SIZE	DWG	NO	SD817R200S		REV	C	