

Gas/Liquid Separators

Type DTL

Dry Type

- For High Solid Loading Applications
- Sizes from 2" to 16"

FEATURES

- Removes 99% of Liquid and Solid Entrainment Particles Larger Than 10 Microns
- No Required Maintenance
- Low Pressure Drop
- Flanged Drain
- Fabricated Carbon or Stainless Steel Construction

OPTIONS

- Larger Sizes
- Code Stamp

Eaton's Dry Type Gas/Liquid Separators are designed for applications with higher than normal loads of entrained solids. In order to handle the large amount of solids, these separators feature a cone-shaped sump that does a better job of collecting removed solids at the drain port. The separated material must be removed before it fills the sump area. Since automatic drain traps are not suitable for handling solid materials, the use of a rotary valve is recommended for this purpose. This allows the solid material to be removed while releasing a minimum amount of air, gas, or steam from the system.

When correctly specified and installed, DTL separators will remove 99% of all entrained liquid droplets and solid particles that are 10 microns in size or larger from an air, gas, or steam stream. The removed particles and liquid accumulate at the drain port at the bottom of the drain sump for removal.

Centrifugal Action

The Type DTL separators cause the gas stream to enter a controlled centrifugal flow, which forces any entrained liquids and solids to the outer wall. The exclusive Eaton Vortex Containment Plate (VCP) system shields these

separated particles and liquid droplets from the vortex action within the separator and directs them toward the drain sump. The exit stream is drawn from the clean, dry center of the separator. The VCP prevents re-entrainment of the removed liquids and solids and assures a clean, dry gas stream at the separator outlet.

Type DTL Separators are available in three different configurations. The Type T-DTL has a straight-through flow connection, the 33L-DTL has a vertical downflow inlet and a horizontal outlet, and the 31L-DTL is a compact, straight-through flow design.

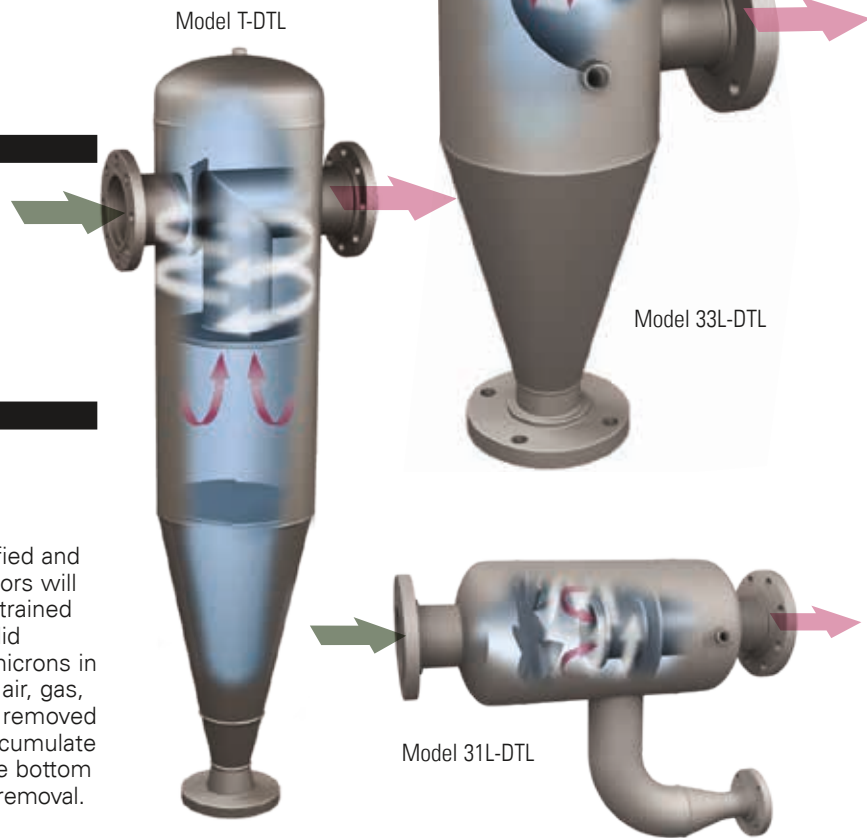

Powering Business Worldwide

Type DTL Dry Type Gas/Liquid Separators

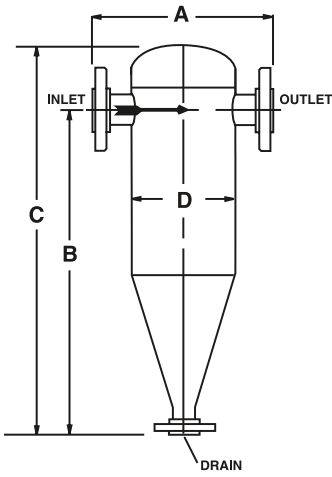

Model T-DTL

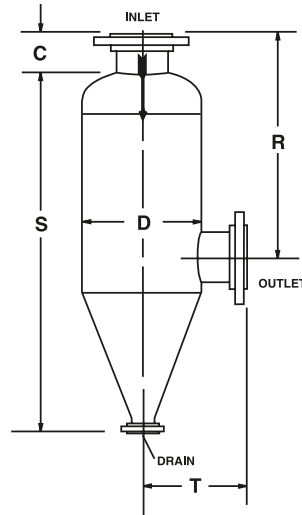

Model 33L-DTL

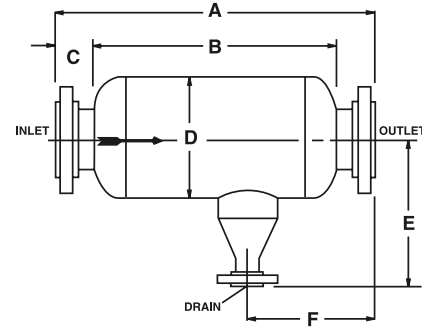

Model 31L-DTL

Dimensions: Type DTL Dry Type Gas/Liquid Separators (in/mm)

Pipe Size	A	B	C	D	Drain Flanged NPT
2	11.5 292	36 914	42 1067	6.62 168	2
2-1/2	16 406	37 940	43 1092	8.62 219	2
3	18 457	42 1067	50 1270	10.75 273	2-1/2
4	20 508	46 1168	55 1397	12.75 324	3
5	22 559	50 1270	60 1524	14 356	4
6	24 610	66 1676	77 1956	16 406	4
8	28 711	74 1880	87 2210	18 457	5
10	33 838	102 2591	117 2972	24 610	5
12	38 965	114 2896	131 3327	28 711	5
14	42 1067	118 2997	138 3505	32 813	8
16	47 1194	133 3378	154 3912	36 914	8

Pipe Size	C	D	R	S	T	Drain Flanged NPT
2	3 76	6.62 168	14 356	26 660	7 178	2
2-1/2	3 76	6.62 168	14 356	26.5 673	7 178	2
3	3 76	8.62 219	16 406	30 762	8 203	2-1/2
4	4 102	10.75 273	20 508	35 889	10 254	2-1/2
5	4 102	12.75 324	24 610	42 1067	11 279	3
6	4 102	14 356	27 686	52.5 1333	12 305	3
8	5 127	16 406	33 838	61 1549	13 330	4
10	5 127	20 508	40 1016	82 2083	15 381	4
12	5 127	24 610	46 1168	98 2489	17 432	5
14	5 127	28 711	52 1321	117 2972	19 483	8
16	5 127	30 762	59 1499	126 3200	20 508	8

Pipe Size	A	B	C	D	E	F	Drain Flanged NPT
2	22 559	16 406	3 76	6.62 168	16 406	11 279	2
2-1/2	22 559	16 406	3 76	6.62 168	16 406	11 279	2
3	24 610	18 457	3 76	8.62 219	17 432	11 279	2-1/2
4	30 762	22 559	4 102	10.75 273	19 483	13.5 343	2-1/2
5	34 864	26 660	4 102	12.75 324	21 533	14 356	3
6	36 914	28 711	4 102	14 356	22 559	14 356	3
8	46 1168	36 914	5 127	16 406	23 584	19 483	4
10	52 1321	42 1067	5 127	20 508	26 660	20.5 521	4
12	60 1524	50 1270	5 127	24 610	29 737	23.5 597	5
14	66 1676	56 1422	5 127	28 711	35 889	25 635	8
16	74 1880	64 1626	5 127	30 762	44 1118	28 711	8

North America
44 Apple Street
Tinton Falls, NJ 07724
Toll Free: 800 656-3344
(North America only)
Tel: +1 732 212-4700

China
No. 3, Lane 280,
Linhong Road
Changning District, 200335
Shanghai, P.R. China
Tel: +86 21 5200-0099

Europe/Africa/Middle East
Auf der Heide 2
53947 Nettersheim, Germany
Tel: +49 2486 809-0

Friedensstraße 41
68804 Aitlußheim, Germany
Tel: +49 6205 2094-0

Am den Nahewiesen 24
55450 Langenlonsheim, Germany
Tel: +49 6704 204-0

Singapore
100G Pasir Panjang Road #07-08
Singapore 118523
Tel: +65 6825-1668

Brazil
Av. Ermano Marchetti, 1435 -
Água Branca, São Paulo - SP,
05038-001, Brésil
Tel: +55 11 3616-8461

**For more information, please
email us at filtration@eaton.com
or visit www.eaton.com/filtration**

US
07-2019

© 2019 Eaton. All rights reserved. All trademarks and registered trademarks are the property of their respective owners. All information and recommendations appearing in this brochure concerning the use of products described herein are based on tests believed to be reliable. However, it is the user's responsibility to determine the suitability for his own use of such products. Since the actual use by others is beyond our control, no guarantee, expressed or implied, is made by Eaton as to the effects of such use or the results to be obtained. Eaton assumes no liability arising out of the use by others of such products. Nor is the information herein to be construed as absolutely complete, since additional information may be necessary or desirable when particular or exceptional conditions or circumstances exist or because of applicable laws or government regulations.



Powering Business Worldwide

