

NOZZLE SCHEDULE			
ITEM	QTY.	NAME	DESCRIPTION
N1	1	INLET	8" - 150# RFSO ASME B16.5
N2	1	OUTLET	8" STD WT PIPE
N3	1	DRAIN	2" NPT 3000# COUPLING

REV	DATE	CHANGE	ECR	BY	APP
A	--	NEW ISSUE	--	FG	THM
B	7/18/02	REVISED D. TEMPERATURE	A703	FG	THM
C	12/05/03	DELETED NAMEPL. BRACKET, NAMEPL., INLET TAG, ADDED EXHAUST HEAD NAMEPL.	B892	LH	FM
D	11/1/05	REVISED TITLE BLOCK	D507	FM	LH

NOTES:

1. ALL DIMENSIONS ARE IN INCHES.
2. ALL BOLT HOLES ARE TO STRADDLE NATURAL CENTERLINES.
3. SHIPPING WEIGHT: 240 POUNDS.
4. DESIGN DATA:
 - DESIGN PRESSURE- ATMOSPHERIC
 - DESIGN TEMPERATURE- AMBIENT (MAX. 650° F)
 - CORROSION ALLOWANCE- 0 INCHES
5. MATERIAL: CARBON STEEL.

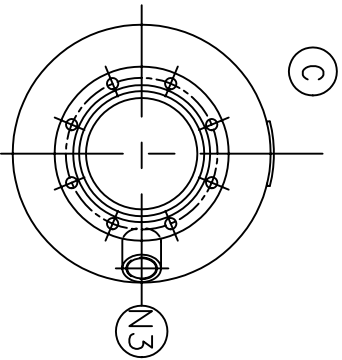
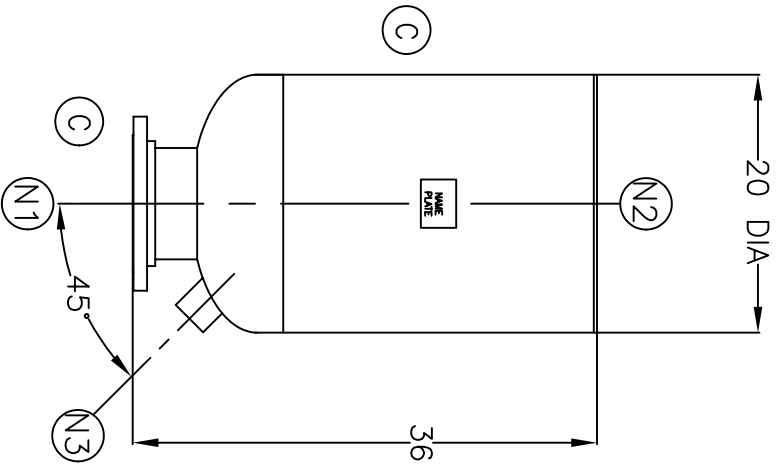

ELECTRONIC FILE NAME:
SD8EHC.DWG

TOLERANCES UNLESS OTHERWISE SPECIFIED
PER ENGINEERING STANDARD ES- --

UNAUTHORIZED USE, MANUFACTURE OR
REPRODUCTION IN WHOLE OR IN PART IS
PROHIBITED. DRAWING, DESIGN AND
OTHER DISCLOSURES PROPERTY OF
EATON FILTRATION, LLC

		EATON FILTRATION, LLC 900 FAIRMOUNT AVENUE, ELIZABETH, NEW JERSEY 07207					
		NAME 8" TYPE "40-EHMF" EXHAUST HEAD 150# FLG CSTL					
DRAWN	FG	DATE	12/8/99	CHECKED	THM	DATE	12/8/99
APP	--	DATE	--	SCALE	NTS	ECR	---
SIZE	DWG	SD8EHC		REV	D		