

## Differential pressure indicator - connection and data

Medium confronted parts made of aluminium precision casting

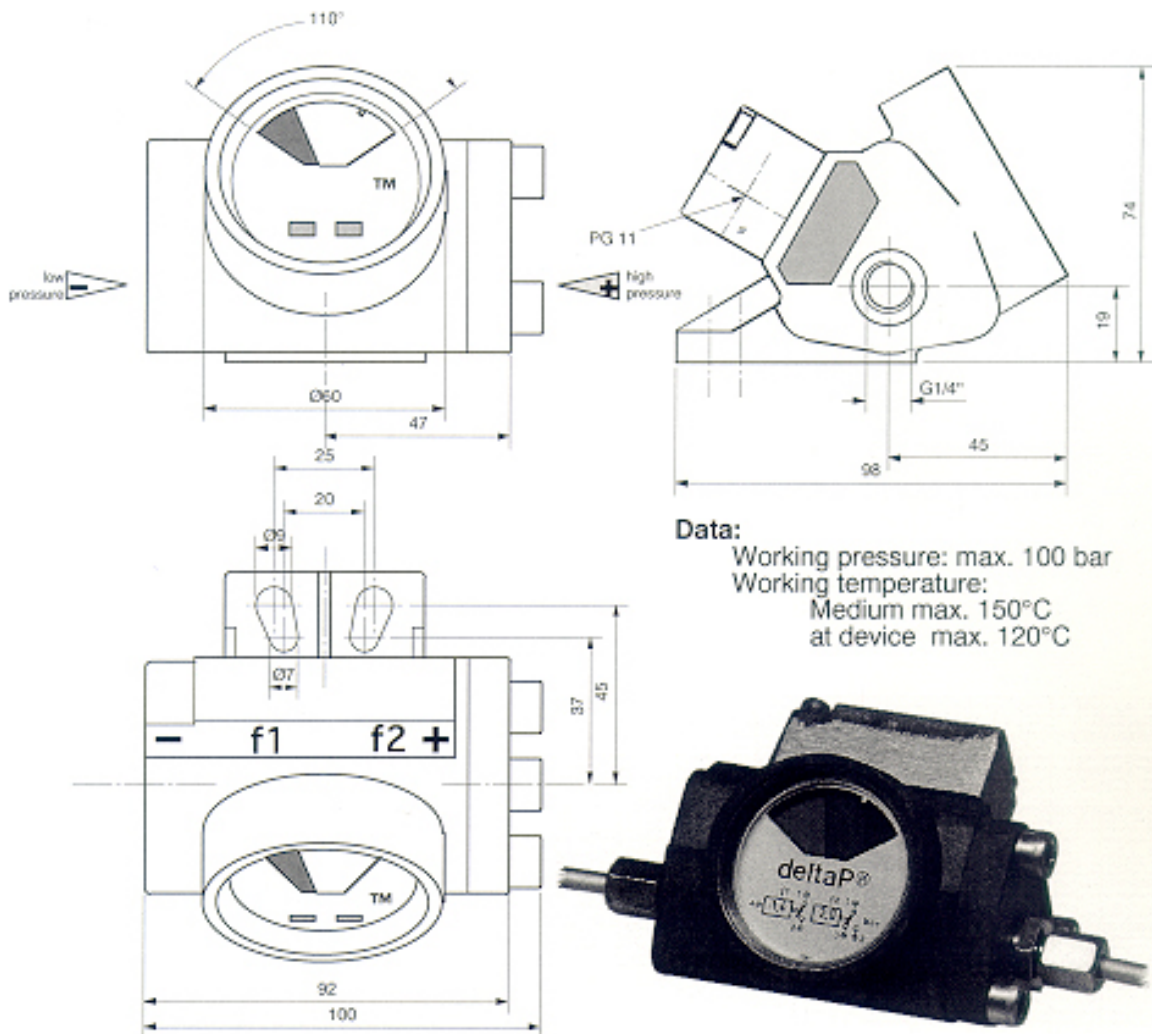

- Application** The deltaP - Differential Pressure Indicators are used for the monitoring of a variable pressure difference via an optical display and electrical contacts in up to two points.
- Description** A piston, hermetically sealed, moves against the effect of a calibrated measuring spring. The piston's position is transmitted magnetically, which means without friction, to an indicating display and in addition to Reed-contacts for electrical signals. In the range of 10...100%  $\Delta p$ , monitored by 0... 110° display-angle, the red part of the display becomes visible. In the standard version at 75%  $\Delta p$  (mark in the display) usually the first (f1), at 100%  $\Delta p$  the second (f2) Reed-contact is switched. The switching points are engraved into the display.
- Connection** Connection should be done workmanlike, to ensure proper function. The device is prepared for G1/4" - pipe-connectors. Sealing can be done with gaskets, PTFE-Tape or glue. The low pressure is to be connected to the side marked with "-", the high pressure to the side marked with "+".  
 Electrical connection: see special supplement

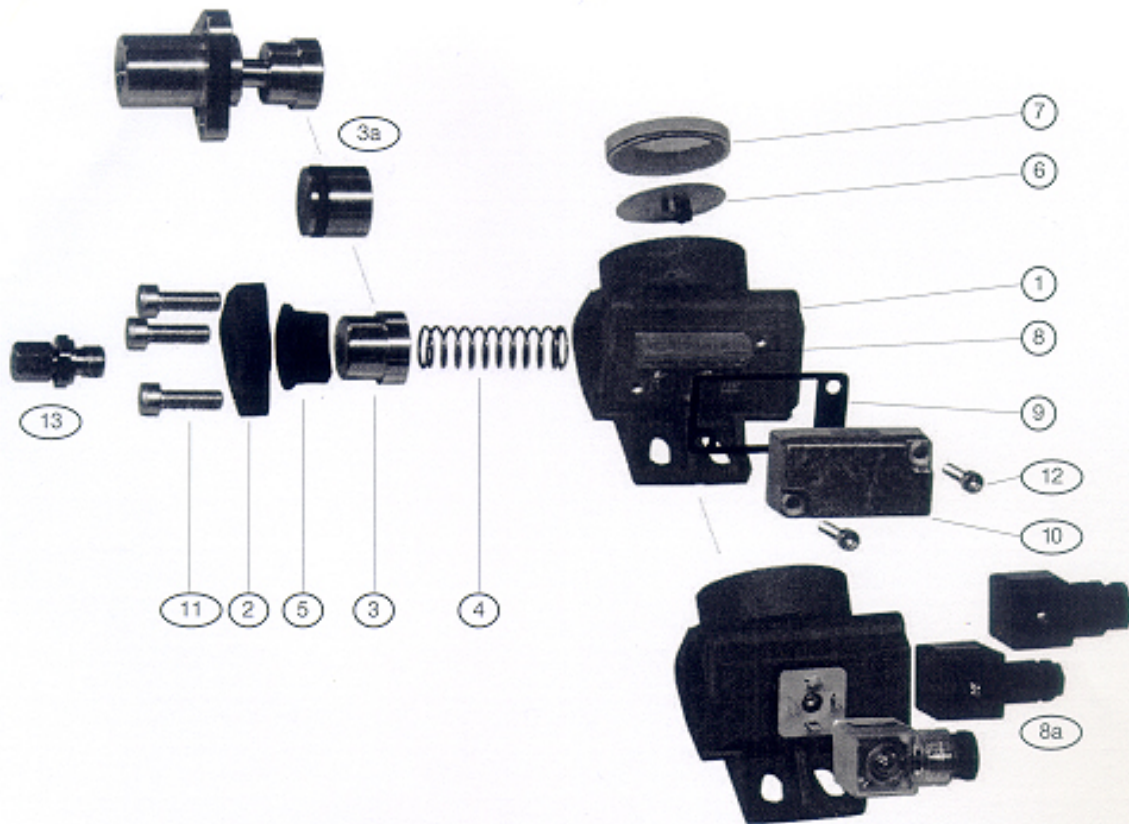

No.	Name	Material / DIN	optional
1	Casing	GK AISI 12, hardcoated	
2	Cover	GK AISI 12, hardcoated	
3	Piston with ring-magnet	Ms, Bariumferrite	Stainless steel, special materials
3a	Special piston	Special gaskets instead of rolling diaphragm (Kotef / O-Rings)	Adapter für $\Delta p > 5$ bis $\leq 20$ bar
4	Measuring spring	1.4310	PTFE-surface, special materials
5	Rolling diaphragm	Perbunan	Viton, EP
6	Display disk (blue/red) with magnet	Aluminum ,Brass, Bariumferrite	
7	Display	Polycarbonat (Makrolon)	
8	Clamp	Plastic material, Brass (tin surface)	Plug systems
8a	Plugs	DIN 43650	others on request
9	Gasket for cover	Perbunan	
10	Cover	GK AISI 12	
11	Screw	DIN 912 M8x25 stainless steel	
12	Screw	DIN 912 M6x25 stainless steel	
13			Pipe-connectors G1/4"

**Maintenance** deltaP - Differential pressure indicators generally need no maintenance.

Though the rolling diaphragm can be damaged because of aging or very high differential pressure loads.



*If the rolling diaphragm or the gasket is damaged the differential pressure can't be monitored correctly!*

Herewith it can come because of the narrow fit size to an only slight by-pass flow through the inside of the indicator. However the instrument interior can pollute thereby. If constant differential pressure should be indicated during an unusually long time it is advisable to check the instrument interior for pollution and especially to check the rolling diaphragm or gasket for damages. If necessary the instruments interior and the connection pipings are to be cleaned and the gaskets changed. When installing the rolling diaphragm it is to be paid attention of fitting the nipples in the bottom of the diaphragm to the piston's side.

### CIRCUIT DIAGRAM:

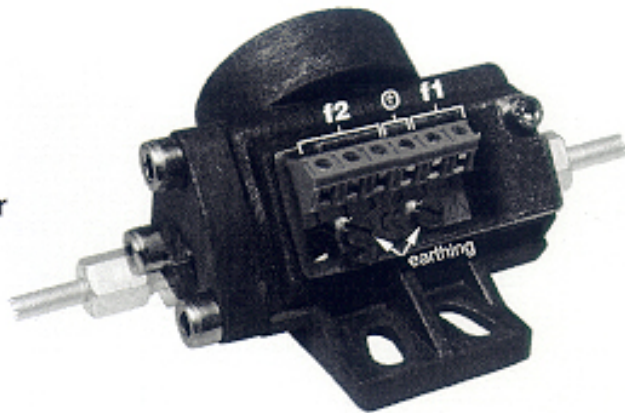
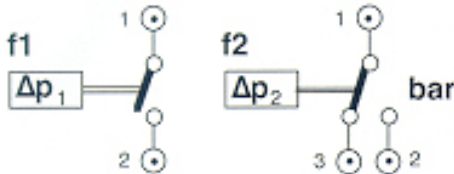

### ATTENTION:



Electrical connection of the Differential pressure indicator is to be done by specialists (e.g. electricians) to prevent damages. In any case the connection cables are to be separated from mains supply before.

### CABLE PREPARATION:

Before connection prepare the cable ends with tin or cable end sleeves.

### CONTACTS:

The contacts are switched according to the above-mentioned circuit diagram. The respective differential pressure, engraved into the display ( $\Delta p_1$ ,  $\Delta p_2$ ) controls the contacts (f1, f2). Each contact is associated a clamp on the reverse of the differential pressure indicator. This is protected with a sealed aluminum cover.

The clamp description is found on the the plate and on the upper side of the casing.

Connection to earth can be either made via the clamps or the brass-screws which hold the plate. At loss of these screws they are absolutely to replace, because they serve simultaneously as fastening bolts for the plate.

### CONNECTION:

Before connection to the clamps, the cable must be led through any kind of PG-11 cable screw, the aluminum cover and it's gasket. Subsequently the cables can be connected according to the above-mentioned circuit diagram. The max. tightening moment is 2Nm.

Finally the aluminum cover is to be screwed with the casing.



### Electrical Data:

Contact		f1	f2
switching ability	max. W	120	30
switching ability	max. VA	120	60
switching voltage	max. V $\equiv$	250	250
switching current	max. A	3	1
constant current	max. A	5	2
Voltage-proof up to	V	800	500
volume resistance	max. m $\Omega$	100	100
isolation resistance	typ. $\Omega$	10 <sup>11</sup>	10 <sup>9</sup>
cable diameter	max. mm <sup>2</sup>	1,5	1,5
high-voltage-tested against earth up to 1350 VAC			
Isolation protection class IP 65			