

ITEM NUMBER	BAG SIZE	A IN. / MM	B IN. / MM	C IN. / MM	D IN. / MM	E IN. / MM	F IN. / MM	G IN. / MM	WEIGHT LBS / KGS
SBF0111SB02F	01	8-11/16 / 220	19-1/2 / 495	26-5/8 / 676	14-3/8 / 365	38 / 965	19-1/4 / 489	8-5/8 / 219	84 / 38.1
SBF0112SB02F	02	8-11/16 / 220	35 / 889	42-1/8 / 1070	14-3/8 / 365	69 / 1753	19-1/4 / 489	8-5/8 / 219	102 / 46.3

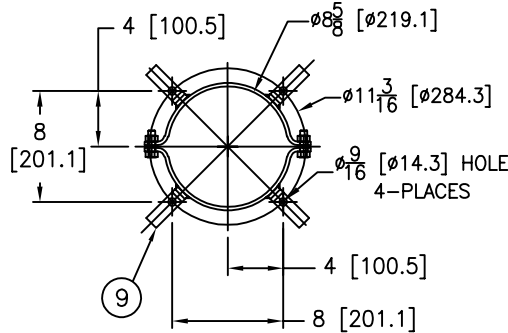
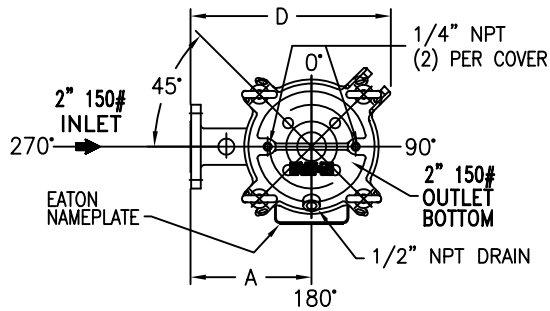

**BOTTOM VIEW**

REVISIONS				
REV	DESCRIPTION	BY	ECO	DATE
G	UPDATED DRAWING NOTE 1	FJM	0119283	01/26/16

NO.	PART NAME	MATERIAL
1	BODY	SA-351 CF8M SA-312 TP 316
2	PIN	SA-193 GR B7, ZINC PL.
3	EYE BOLT	SA-193 GR B7, ZINC PL.
4	EYE NUT	SA-194 GR 2H ZINC PL.
5	COVER	SA-351 CF8M
6	O-RING P/N L0000024	BUNA
7	BAG HOLD DOWN	316 STAINLESS STEEL
8	RESTRAINER BASKET P/N L0001752 01 SIZE P/N L0001753 02 SIZE	316 STAINLESS STEEL
9	ADJUSTABLE CLAMP-ON SUPPORT LEGS P/N L0002940SA-CSTL	CARBON STEEL EPOXY COATED

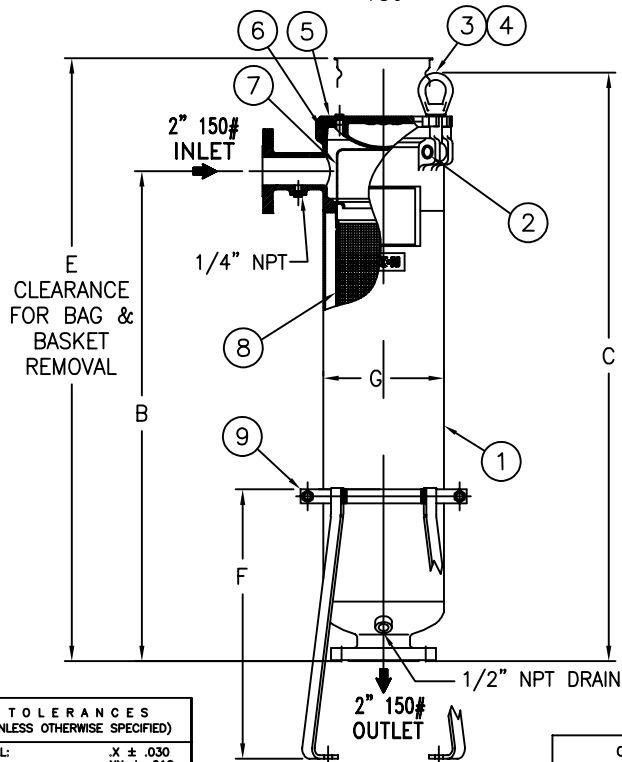

**NOTES:**

- UNITS ARE DESIGNED, FABRICATED AND "UM" STAMPED IN ACCORDANCE WITH THE ASME BOILER & PRESSURE VESSEL CODE SECTION VIII, DIVISION 1, IN COMPLIANCE TO CURRENT MANDATORY EDITION.
- INLET/OUTLET FLANGED CONNECTIONS PER ANSI B16.5.
- MAWP: 150 PSI @ 250° F MDMT: -20° F @ 150 PSI  
(10.3 BAR @ 121.1° C) (-28.9° C @ 10.3 BAR)
- MAXIMUM OPERATING TEMP. 400° F (204.1° C) WITH VITON O-RING.
- DIMENSIONS SHOWN IN [ ] ARE IN MILLIMETERS AND FOR REFERENCE ONLY. ACCEPTANCE OF THIS PART WILL BE BASED ON "INCH" UNITS & TOLERANCES ONLY.

SBF0111SB02F VESSEL CODE: SBF-0101-AB10-020A-MS-B-NCS

SBF0112SB02F VESSEL CODE: SBF-0102-AB10-020A-MS-B-NCS

TOLERANCES (UNLESS OTHERWISE SPECIFIED)	
DECIMAL:	.X ± .030 .XX ± .010 .XXX ± .005
FRACTIONAL:	± 1/16 ± 1/32
NOZZLE Ø TO FLOOR:	1/8" < 4' > 1/4"
FACE TO FACE:	1/8" < 4' > 1/4"
ANGULAR:	± 1'
FLANGES (H/V):	± 1/2"
VESSEL OVERALL HT:	1"

REVIEWED FOR CLASSIFICATION PER PR-4  
 CRITICAL SIGNIFICANT

CUSTOMER INFO	
NAME	
P.O. NO.	
S.O. NO.	
QUANTITY	
PART NO.	SEE ABOVE

DRAWN BY LF		HYDRAULICS GROUP FILTRATION DIVISION GALESBURG, MICHIGAN, USA • TINTON FALLS, NEW JERSEY, USA		
SCALE AS DRAWN		TITLE SIDELINE (SBF) BAG FILTER 2" 150# RF FLANGED CONNECTIONS MAT'L. SS-316		
RESTRICTION RESTRICTED		DATE 07/27/99	SIZE A	DWG FILENAME SBF11XS
SHEET 1 OF 1		REV G		

EATON CORPORATION - CONFIDENTIAL AND PROPRIETARY NOTICE TO PERSONS RECEIVING THIS DRAWING AND/OR TECHNICAL INFORMATION  
THIS DOCUMENT, INCLUDING THE DRAWING AND INFORMATION CONTAINED THEREON IS CONFIDENTIAL AND IS THE EXCLUSIVE PROPERTY OF EATON AT ANY TIME. BY TAKING THE POSSESSION OF THIS DOCUMENT THE RECIPIENT ACKNOWLEDGES AND AGREES THAT THIS DOCUMENT CANNOT BE USED IN ANY MANNER ADVERSE TO THE INTEREST OF EATON AND THAT NO PORTION OF THIS DRAWING MAY BE COPIED OR OTHERWISE REPRODUCED WITHOUT THE PRIOR WRITTEN CONSENT OF EATON, IN THE CASE OF CONFLICT CONTRACTUAL PROVISIONS, THIS NOTICE SHALL GOVERN THE STATUS OF THIS DOCUMENT.  
2014 EATON CORPORATION - ALL RIGHTS RESERVED.