

(4) .875 [22.2] Ø BOLT HOLES
LOCATED ON 36.5 [927.1] B.C.D.

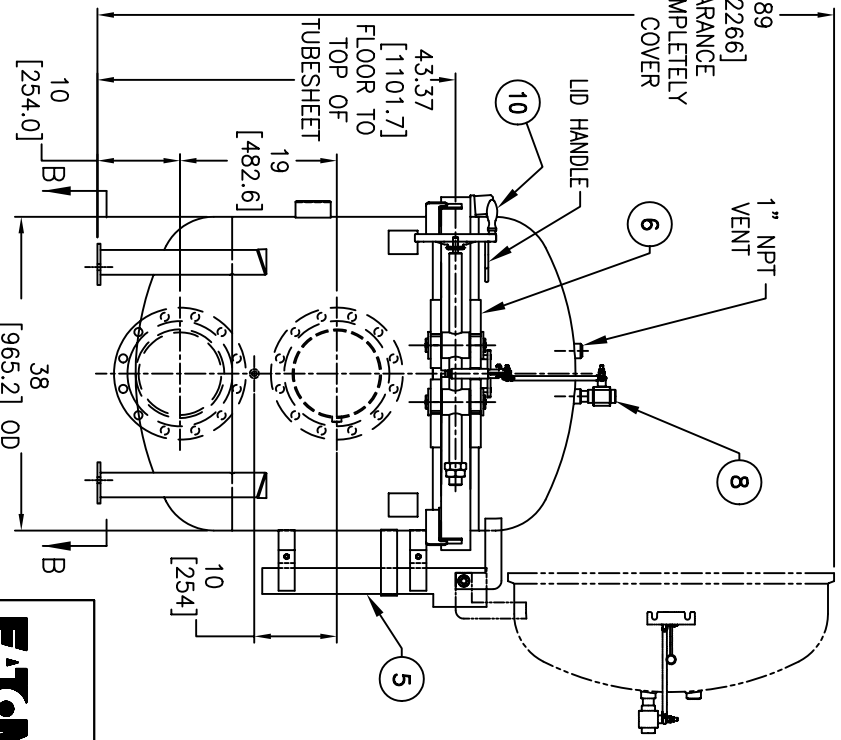
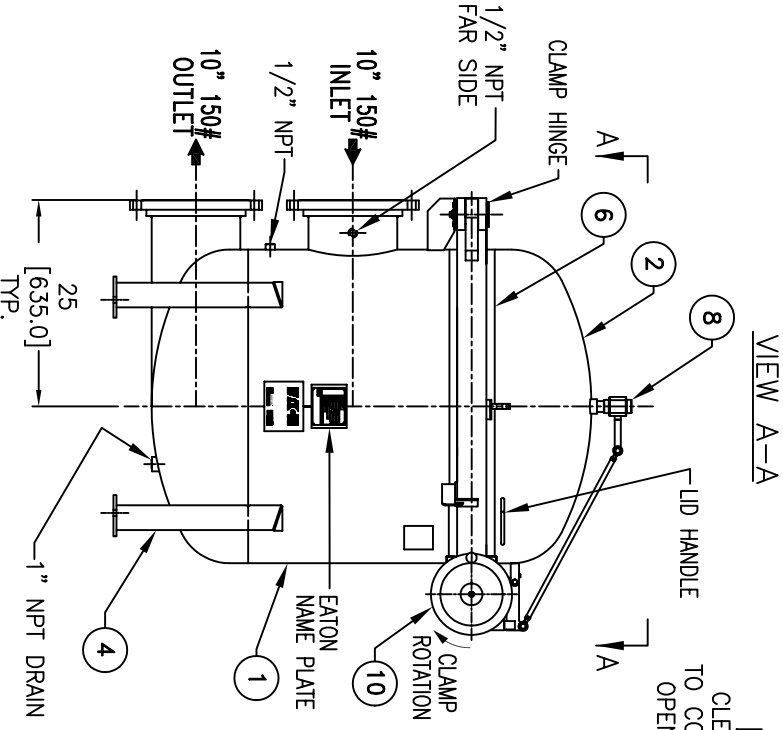
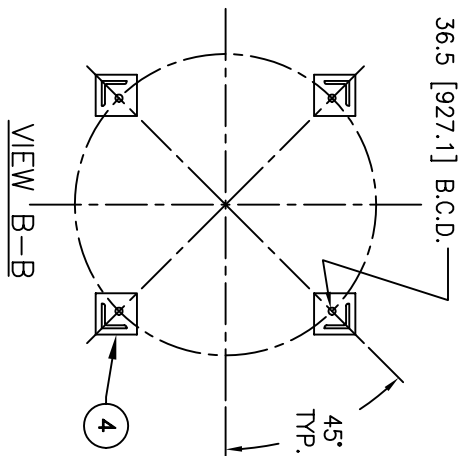

ITEM	PART NAME	MATERIAL
1	BODY	SA240-304/304L
2	COVER	SA240-304/304L
3	O-RING	BUNA-N
4	LEGS	STAINLESS STEEL
5	SPRING ASSISTED MECHANISM	STAINLESS STEEL
6	CLAMP ASSEMBLY	STAINLESS STEEL
7	FILTER BAG HOLD DOWN	304 SS
8	1" VENT VALVE ASSY.	304 SS
9	SPINDLE BOLT	SA193-B7 NEDOX COATED
10	SPINDLE HANDLE	ALUMINIUM

NOTES:

1. UNITS ARE DESIGNED, FABRICATED & U STAMPED IN ACCORDANCE WITH ASME SECT. VIII, DIV. 1 BOILER & PRESSURE VESSEL CODE, IN COMPLIANCE TO LATEST ADDENDA.
2. INLET/OUTLET FLANGE CONNECTIONS PER ANSI B16.5
3. DESIGN PRESSURE: 150 PSIG @ 250°F (10.3 BAR @ 121.1°C)
4. ALL DIMENSIONS ARE IN INCHES / [mm]
5. ALL BOLT HOLES STRADDLE NATURAL CENTERLINE.
6. APPROX. WEIGHT (DRY): 1070 lbs. (485 kgs.)
7. APPROX. SHIPPING WEIGHT 1210 lbs. (548 kgs.)

CERTIFIED FOR:
 P.O. NO.:
 REG. NO.:
 QUOTE NO.:
 TAG NO.:
 VESSEL CODE: V-MBF-1202-BB10-100A-UT-11SE-LOOP
 PART NUMBER: F3AV1200200L304



EATON FILTRATION, LLC
 900 FAIRMOUNT AVENUE, ELIZABETH, NEW JERSEY 07207

NAME: MBF-1202 FILTER VESSEL
 10"-150# INLET/ TANGENTIAL OUTLET
 SPINDLE TYPE-SE (SS-304)

ELECTRONIC FILE NAME: SE1210TSL304.DWG
 REF. ECR E023
 DATE 06/20/06

UNAUTHORIZED USE, MANUFACTURE OR REPRODUCTION IN WHOLE OR IN PART IS PROHIBITED. DRAWING, DESIGN AND OTHER DISCLOSURES PROPERTY OF EATON FILTRATION, LLC

DATE	BY	DATE	REV
06/20/06	VA	06/20/06	A

SE1210TSL304