

| REVISIONS | | | |
|-----------|----------------|-----|------------------|
| REV | DESCRIPTION | BY | DATE |
| E | UPDATE DRAWING | FJM | 0124501 06/30/16 |

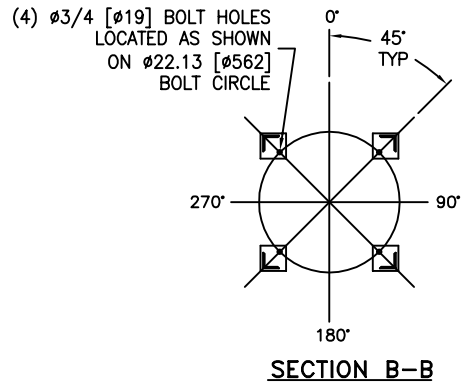

| ITEM | PART NAME | MATERIAL |
|------|--------------------------------|------------------|
| 1 | BODY | SA516 GR. 70 |
| 2 | COVER | SA516 GR. 70 |
| 3 | O-RING P/N 2375036593 | BUNA-N |
| 4 | PIN | SA193 B7 ZINC PL |
| 5 | SNAP RING | STEEL ZINC PL |
| 6 | RESTRAINER BASKET P/N L0001753 | 316 SS |
| 7 | FILTER BAG RETAINER | 316 SS |
| 8 | EYE BOLT | SA354 BD ZINC PL |
| 9 | HEX NUT | SA194 2H ZINC PL |
| 10 | WASHER | STEEL ZINC PL |
| 11 | SPRING ASSISTED MECHANISM | STAINLESS STEEL |

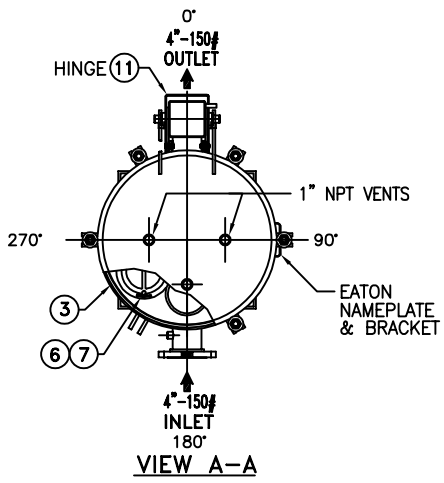
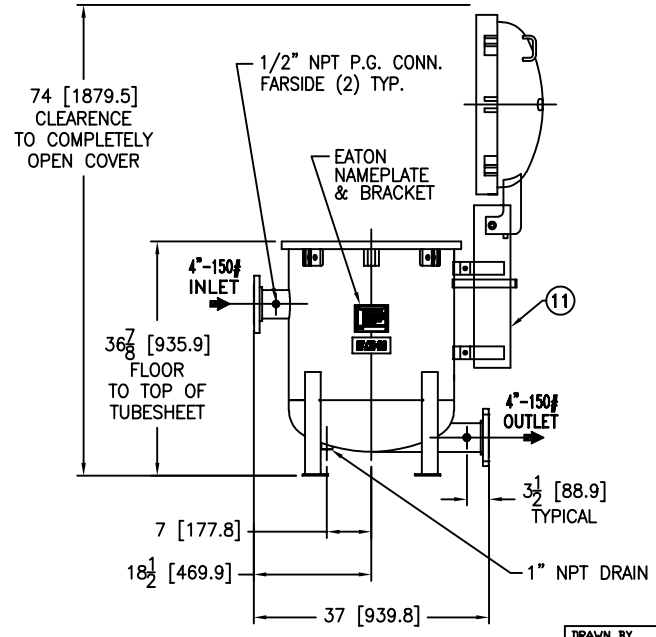
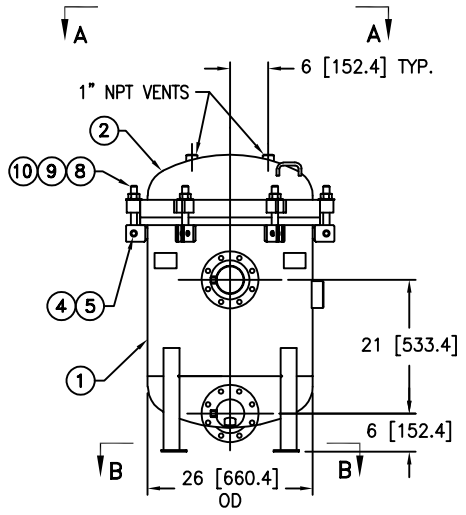

NOTES:

1. UNITS ARE DESIGNED, FABRICATED AND "U" STAMPED IN ACCORDANCE WITH THE ASME BOILER & PRESSURE VESSEL CODE SECTION VIII, DIVISION 1, IN COMPLIANCE TO CURRENT MANDATORY EDITION.
2. INLET / OUTLET FLANGE CONNECTIONS PER ANSI B 16.5.
3. DESIGN PRESSURE: 150 PSI (MAWP)
DESIGN TEMPERATURE 250° F.
MDMT - -20° F @ 150 PSI.
4. DIMENSIONS SHOWN IN [] ARE IN MILLIMETERS AND FOR REFERENCE ONLY. ACCEPTANCE OF THIS PART WILL BE BASED ON "INCH" UNITS & TOLERANCES ONLY.
5. ALL BOLT HOLES ARE TO STRADDLE NATURAL CENTERLINES.
6. APPROX. WEIGHT (DRY) 790 LB. (358 kgs.)
7. APPROX. SHIPPING WEIGHT 915 LB. (415 kgs.)
8. PAINT PER EATON STANDARD ES-301

| TOLERANCES (UNLESS OTHERWISE SPECIFIED) | |
|--|--|
| DECIMAL: | .X ± .030 .XX ± .010 .XXX ± .005 |
| FRACTIONAL: | ± 1/16 ± 1/32 |
| NOZZLE C TO FLOOR: | ± 1/8" < 4' > ± 1/4" |
| FACE TO FACE: | ± 1/8" < 4' > ± 1/4" |
| ANGULAR: | ± 1' |
| FLANGES (H/V): | ± 1/2" |
| VESSEL OVERALL HT: | 1" |

BOLT HOLES MUST STRADDLE C MACHINED PARTS TO BE FREE OF BURRS FOR ADDITIONAL TOLERANCE DETAILS REF. ES-211, ES-222 AND ES-223

REVIEWED FOR CLASSIFICATION PER PR-4

CRITICAL SIGNIFICANT

| CUSTOMER INFO | |
|---------------|-------------|
| NAME | |
| P.O. NO. | |
| S.O. NO. | |
| QUANTITY | |
| PART NO. | F3AV0600103 |

| | |
|-------------|-------------|
| DRAWN BY | FJM |
| SCALE | AS DRAWN |
| RESTRICTION | RESTRICTED |
| SHEET | 1 OF 1 |
| PROJECTION | THIRD ANGLE |

| | | | |
|---|----------|---|---|
| VESSEL CODE: MBF-0602-CS10-040A-UT-13HE | | | |
| | | HYDRAULICS GROUP FILTRATION DIVISION GALESBURG, MICHIGAN, USA • TINTON FALLS, NEW JERSEY, USA | |
| TITLE MAXILINE (MBF-0602 HE) FILTER VESSEL 4" 150# RF INLET / TANGENTIAL OUTLET CARBON STEEL W/BUNA O-RING | | | |
| DATE | 07/27/01 | SIZE | A |
| DWG FILENAME | HE0604TC | REV | E |

EATON CORPORATION - CONFIDENTIAL AND PROPRIETARY NOTICE TO PERSONS RECEIVING THIS DRAWING AND/OR TECHNICAL INFORMATION THIS DOCUMENT, INCLUDING THE DRAWING AND INFORMATION CONTAINED THEREIN IS CONFIDENTIAL AND IS THE EXCLUSIVE PROPERTY OF EATON AT ANY TIME. BY TAKING THE POSSESSION OF THIS DOCUMENT THE RECIPIENT ACKNOWLEDGES AND AGREES THAT THIS DOCUMENT CANNOT BE USED IN ANY MANNER ADVERSE TO THE INTEREST OF EATON AND THAT NO PORTION OF THIS DRAWING MAY BE COPIED OR OTHERWISE REPRODUCED WITHOUT THE PRIOR WRITTEN CONSENT OF EATON. IN THE CASE OF CONFLICTING CONTRACTUAL PROVISIONS, THIS NOTICE SHALL GOVERN THE STATUS OF THIS DOCUMENT.
©2006 EATON CORPORATION - ALL RIGHTS RESERVED.