

ITEM NUMBER	VESSEL CODE	BAG SIZE	A IN. / MM	B IN. / MM	C IN. / MM	D IN. / MM	E IN. / MM	F IN. / MM	G IN. / MM	FLOW RATE GPM (MAX)	WEIGHT LBS / KGS
SBL102CC3ASBSP0	FBF2-0102-CS10-030A	02	7.98 / 180	35.30 / 897	41.93 / 1065	12.15 / 309	68.31 / 1735	19.10 / 485	7.68 / 195	180	69 / 31.4

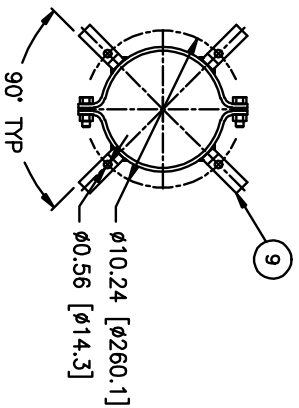
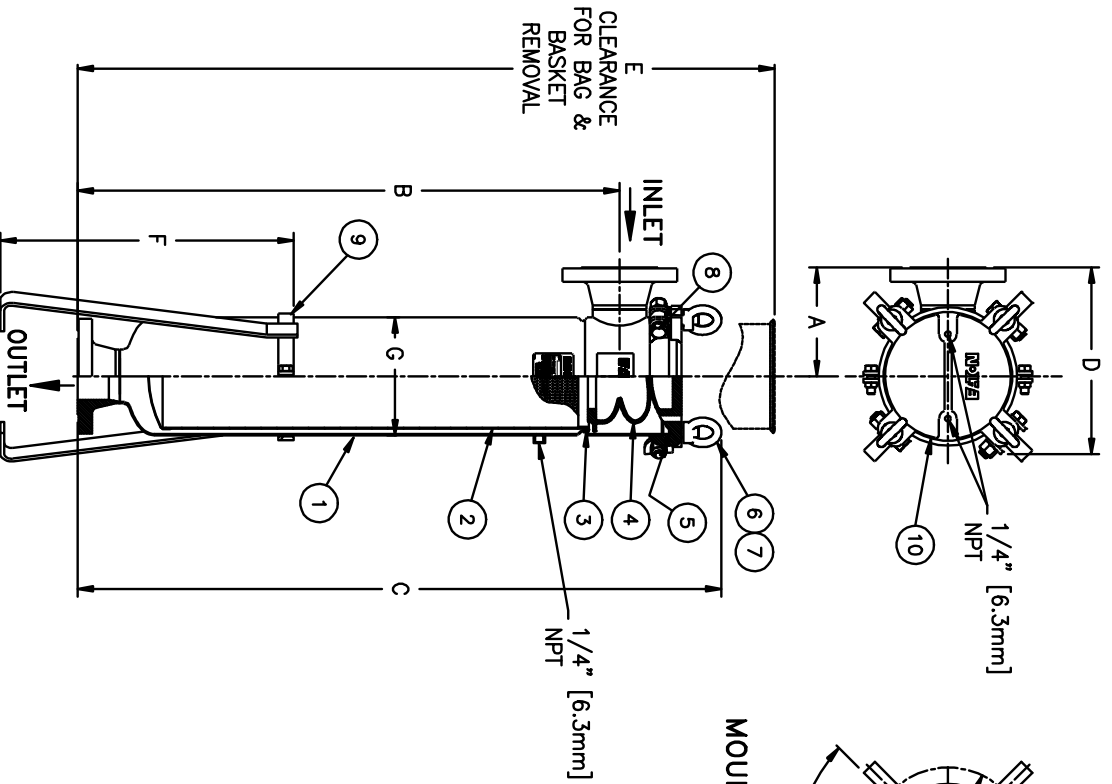

MOUNTING DETAIL

NO.	PART NAME	MATERIAL
1	BODY	CARBON STEEL
2	RESTRAINER BASKET	316 STAINLESS STEEL
3	BASKET O-RING	BUNA-N
4	BAG HOLD DOWN	KYNAR PUDF
5	O-RING	BUNA-N
6	EYE BOLT	STEEL, ZINC PLATED
7	EYE NUT	STEEL, ZINC PLATED
8	BOLT	STEEL, ZINC PLATED
9	LEGS	CARBON STEEL
10	COVER	CARBON STEEL

NOTES:

1. INLET/OUTLET FLANGED CONNECTIONS PER ANSI B16.5
2. MAWP: 150 PSI @ 250° F (-20° F @ 150 PSI (10.3 BAR @ 121.1° C) (-28.9° C @ 10.3 BAR) MIDMT:
3. MAXIMUM OPERATING TEMP. 250° F (121.1° C)
4. PAINT C/STL. PER EATON STANDARD ES-301.

CERTIFIED FOR:  
P.O. NO.:  
SALES ORDER NO.:  
QUANTITY:  
TAG NO.:  
FILTER BAG:

**EATON**  
**EATON FILTRATION, LLC**  
70 WOOD AVENUE SOUTH, ISELIN, NEW JERSEY 08830

NAME: FLOWLINE II FILTER VESSEL  
3" 150# FLANGED CONNECTION  
CARBON STEEL

SIZE	DWG NO	DATE	CERT.	DATE	REV
A		02/10/10			A

ELECTRONIC FILE NAME: FBF202XCF-3.dwg  
REF. EOR DATE 02/10/10

UNAUTHORIZED USE, MANUFACTURE OR REPRODUCTION IN WHOLE OR IN PART IS PROHIBITED. DRAWING, DESIGN AND OTHER DISCLOSURES PROPERTY OF EATON FILTRATION, LLC

FBF202XCF-3