

ITEM NUMBER	VESSEL CODE	BAG SIZE	A IN. / MM	B IN. / MM	C IN. / MM	D IN. / MM	E IN. / MM	F IN. / MM	G IN. / MM	FLOW RATE GPM (MAX)	WEIGHT LBS / KGS
SBL101CS2ASBSP0	FBF2-0101-CS10-020A	01	46.84 / 1174	19.67 / 500	26.54 / 674	11.92 / 303	34.44 / 875	19.10 / 485	7.68 / 195	90	37 / 16.8
SBL102CS2ASBSP0	FBF2-0102-CS10-020A	02	6.84 / 174	34.83 / 885	41.70 / 1059	11.92 / 303	67.52 / 1715	19.10 / 485	7.68 / 195	180	50 / 22.7

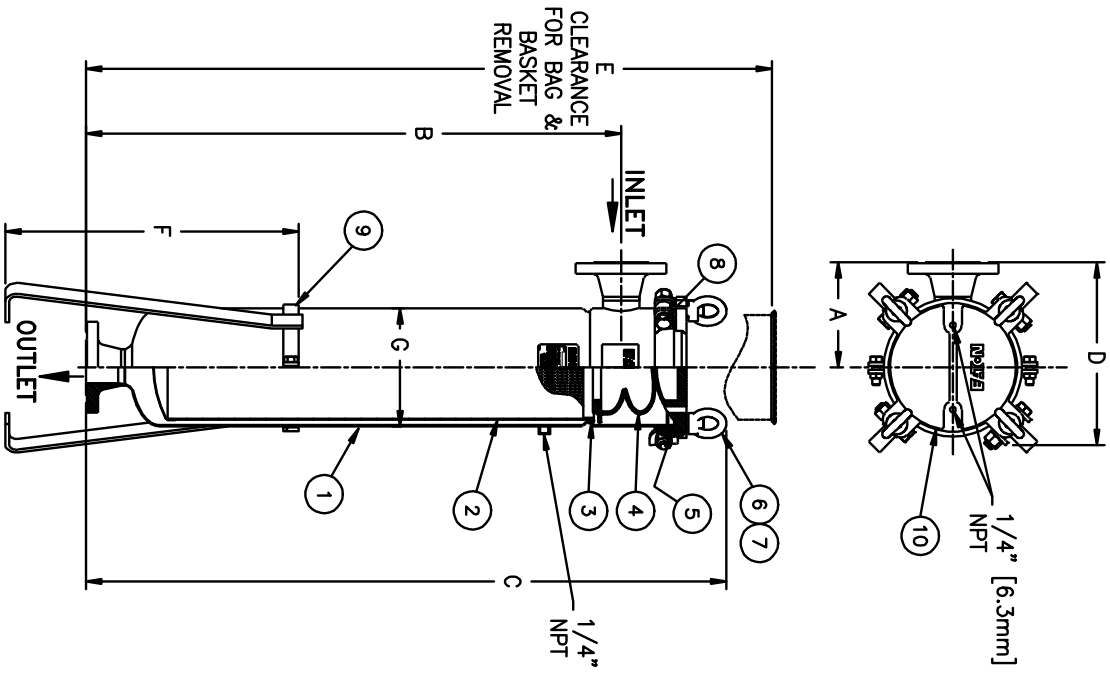

MOUNTING DETAIL

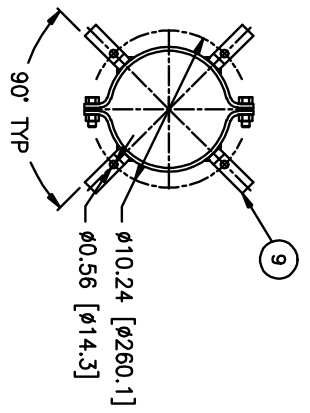

NO.	PART NAME	MATERIAL
1	BODY	CARBON STEEL
2	RESTRAINER BASKET	316 STAINLESS STEEL
3	BASKET O-RING	BUNA-N
4	BAG HOLD DOWN	KYNAR PUDF
5	O-RING	BUNA-N
6	EYE BOLT	STEEL, ZINC PLATED
7	EYE NUT	STEEL, ZINC PLATED
8	BOLT	STEEL, ZINC PLATED
9	LEGS	CARBON STEEL
10	COVER	CARBON STEEL

NOTES:

1. INLET/OUTLET FLANGED CONNECTIONS PER ANSI B16.5
2. MAWP: 150 PSI @ 250° F (-20° F @ 150 PSI (10.3 BAR @ 121.1° C) (-28.9° C @ 10.3 BAR) MIDMT:
3. MAXIMUM OPERATING TEMP. 250° F (121.1° C)
4. PAINT C/STL. PER EATON STANDARD ES-301.

CERTIFIED FOR:
P.O. NO.:
SALES ORDER NO.:
QUANTITY:
TAG NO.:
FILTER BAG:

EATON
EATON FILTRATION, LLC
70 WOOD AVENUE SOUTH, ISELIN, NEW JERSEY 08830

NAME: FLOWLINE II FILTER VESSEL
2" 150# FLANGED CONNECTION
CARBON STEEL

ELECTRONIC FILE NAME: FBF211XCF.dwg
REF. EOR DATE 02/09/10

UNAUTHORIZED USE, MANUFACTURE OR REPRODUCTION IN WHOLE OR IN PART IS PROHIBITED. DRAWING, DESIGN AND OTHER DISCLOSURES PROPERTY OF EATON FILTRATION, LLC

SIZE	DWG NO	DATE	CERT.	DATE	REV
A	FBF211XCF	02/09/10			A