

# Model 2596

2"–8"

*Eaton's Model 2596 automatic self-cleaning cast pipeline strainers are available in 2", 3", 4", 6" and 8" sizes. A 4L" size is also available which allows for greater flow rates. The Model 2596 is recognized across industries for its continuous flow, simplified maintenance, and worry-free operation.*



### Features / Benefits

- Flow rates up to 1,800 gpm (409 m<sup>3</sup>/h)
- A broad selection of screen options
- Automatic backwashing
- Exclusive idL™ seal for leak free service
- Unitized modular assembly for easy maintenance
- Cenpeller™ technology for more efficient and complete backwashing
- Cast iron or stainless steel construction
- Standard motor
- Flanged can be also drilled according to DIN standard

The Eaton Model 2596 automatic self-cleaning strainer is designed for the continuous removal of entrained solids from liquids in pipeline systems.

With an automated control system monitoring the strainer operation, cleaning is accomplished by an integral backwash system. A small portion of the screen element is isolated and cleaned by reverse flow while the remaining screen area continues to strain—providing uninterrupted flow. This efficient design uses only a small amount of the liquid being strained to carry debris away from the strainer element.

The Model 2596 features the idL shaft seal that positively prevents leakage from the backwash shaft at the top of the strainer. This unique quad seal keeps the exterior of the strainer dry and prevents external leakage or weeping of the process media down the sides of the strainer.

The 2" to 8" size strainers feature Eaton's Cenpeller technology, which directs incoming liquid into a circular flow—forcing the debris to lay up against the surface of the strainer element in a way that makes backwashing easier and more efficient and greatly reduces the need for manual cleanouts.

To simplify maintenance the Model 2596 features a unitized modular assembly. The motor, gear reducer, and the internal operating mechanism are housed within the strainer cover and lift off as a unit. This makes all components easily accessible and reduces associated maintenance costs.



Powering Business Worldwide

# Model 2596 2"–8" Automatic Self-Cleaning Strainers

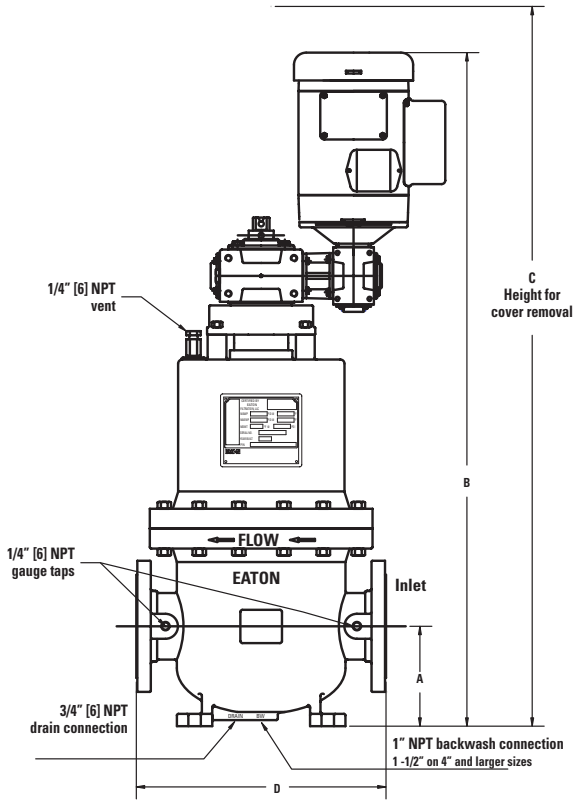

**Model 2596 2"–8" Flow rates**

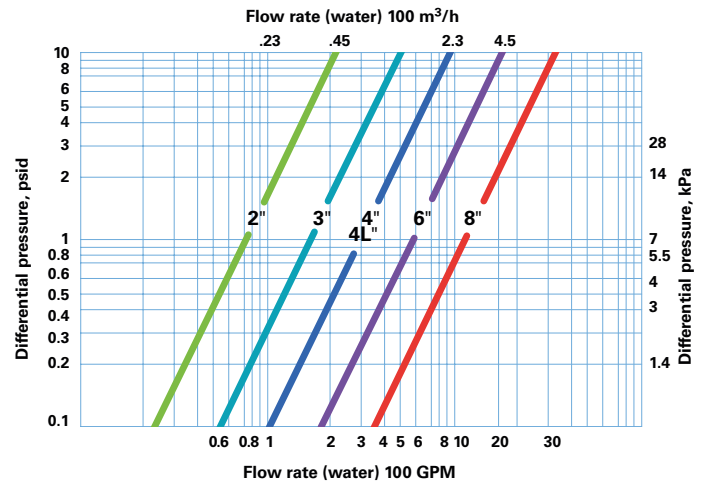

Pressure drop data indicates results to be expected with clean water, under normal flows with standard screens and in clean strainer.

Size	Approximate Dimensions (in)				Approximate Weight (lb)		
	A	B	C	D	Dry	Wet	Cover
2"	6	40½	42½	15	328	382	164
3"	6	40½	42½	15	344	399	164
4"	7	42	44	15	353	413	164
4"L	8	52	55	23½	805	998	438
6"	8	55	58	23½	836	1,081	438
8"	8	55	58	23½	901	1,129	438

Dimensions are for reference only. For installation purposes, request certified drawings.

## Strainer Media

### DuraWedge® Element

DuraWedge is a nonclogging, rugged stainless steel element for the most demanding applications. It is constructed from V-shaped profile wire. A wide range of opening sizes is available.



### Convuluted Element

A sturdy, economical stainless steel element for general service use. Available perforated openings of 1/8", 1/16", and 1/32". Available mesh sizes of 20, 40, 60, 80, 100, 150, and 200 mesh.



## Model 2596 Cv factors\*

Size	2"	3"	4"/4L"	6"	8"
Value	78	163	295	580	1,150

\* For water with clean, perforated basket

## Application Limits

- Cast Iron Class 125 Flange (-20 to 150°F) 200 psi (2" to 8")
- Cast 316 Stainless Steel Class 150 Flange (-20 to 100°F) 275 psi (2" to 4")
- 6" to 8" Fabricated Class 150 Flange (150°F) 150 psi

**North America**  
44 Apple Street  
Tinton Falls, NJ 07724  
Toll Free: 800 656-3344  
(North America only)  
Tel: +1 732 212-4700

**Greater China**  
No. 7, Lane 280,  
Linhong Road  
Changning District, 200335  
Shanghai, P.R. China  
Tel: +86 21 5200-0099

**Europe/Africa/Middle East**  
Auf der Heide 2  
53947 Nettersheim, Germany  
Tel: +49 2486 809-0

**Asia-Pacific**  
100G Pasir Panjang Road  
#07-08 Interlocal Centre  
Singapore 118523  
Tel: +65 6825-1668

Friedensstraße 41  
68804 Altlußheim, Germany  
Tel: +49 6205 2094-0  
An den Nahewiesen 24  
55450 Langenlonsheim, Germany  
Tel: +49 6704 204-0

For more information, please  
email us at [filtration@eaton.com](mailto:filtration@eaton.com)  
or visit [www.eaton.com/filtration](http://www.eaton.com/filtration)

© 2022 Eaton. All rights reserved. All trademarks and registered trademarks are the property of their respective owners. All information and recommendations appearing in this brochure concerning the use of products described herein are based on tests believed to be reliable. However, it is the user's responsibility to determine the suitability for his own use of such products. Since the actual use by others is beyond our control, no guarantee, expressed or implied, is made by Eaton as to the effects of such use or the results to be obtained. Eaton assumes no liability arising out of the use by others of such products. Nor is the information herein to be construed as absolutely complete, since additional information may be necessary or desirable when particular or exceptional conditions or circumstances exist or because of applicable laws or government regulations.

US  
05-2022