

PIPE SIZE (NOMINAL)	DIMENSIONS			WEIGHT			PART NUMBER
	A IN. MM.	B IN. MM.	C IN. MM.	COVER LB. KG.	DRY LB. KG.	WET LB. KG.	
2" (50mm)	6 / 153	40.50 / 1029	42.50 / 1080	164 / 74.5	328 / 149	382 / 174	25960200073
3" (75mm)	6 / 153	40.50 / 1029	42.50 / 1080	164 / 74.5	344 / 156	399 / 181	25960300073
4" (100mm)	7 / 178	42 / 1067	44 / 1118	164 / 74.5	353 / 160	413 / 188	25960400073

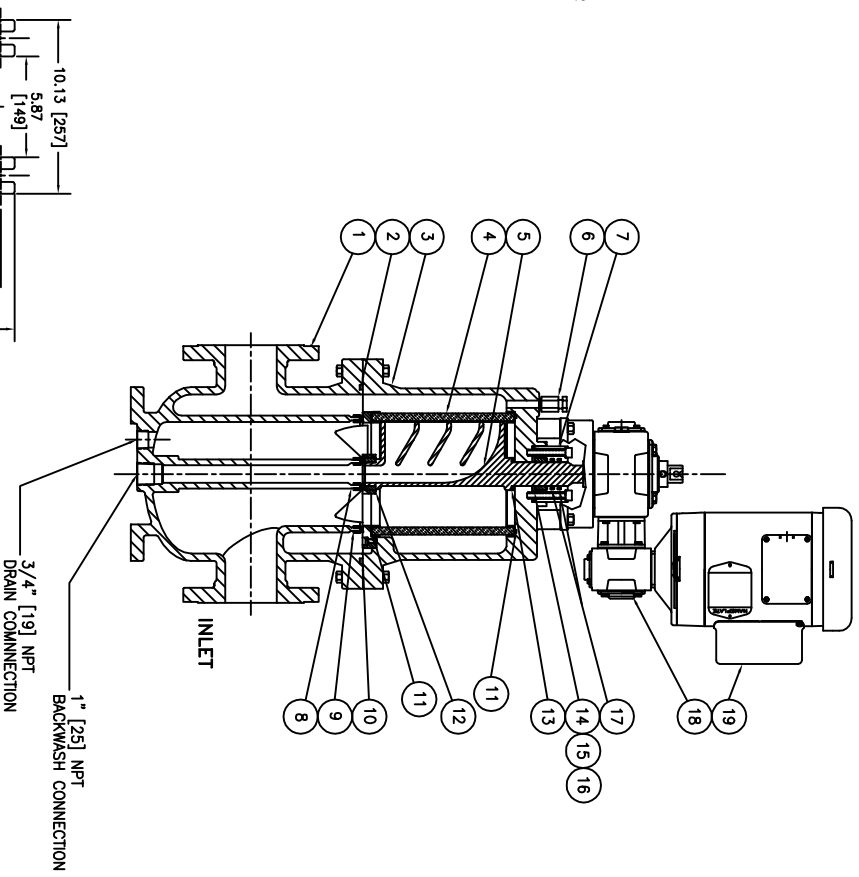

NO.	PART NAME	MATERIAL
1	BODY	A351 CF8M
2	COVER	A351 CF8M
3	CENPELLER SUPPORT	316 STAINLESS STEEL
4	STRAINING ELEMENT	316 STAINLESS STEEL
5	BACKWASH ARM-SHAFT	316 STAINLESS STEEL
6	VENT	STAINLESS STEEL
7	IDL™ HOUSING	316 STAINLESS STEEL
8	INNER SEAL	VTN
9	OUTER SEAL	VTN
10	GIRTH O-RING	VTN
11	ELEMENT O-RING	VTN
12	LOWER BUSHING	COMPOSITE
13	SHAFT WASHER	NYLON
14	SHAFT GASKET	VTN
15	UPPER BUSHING RING	TEFLON
16	UPPER BUSHING	COMPOSITE
17	SHAFT SEAL RINGS	VTN
18	GEAR REDUCER	CAST IRON
19	MOTOR	1/4 HP

- NOTES:
1. ALL FLANGE CONNECTIONS PER ASME/ASTM B16.5.
  2. FOR REPLACEMENT PARTS, MODEL NO., SIZE AND SERIAL NUMBER FROM THE STRAINER NAMEPLATE MUST BE FURNISHED.
  3. DESIGN PRESSURE: 275 PSI @ 100° F [18.9 BAR @ 37.7° C]

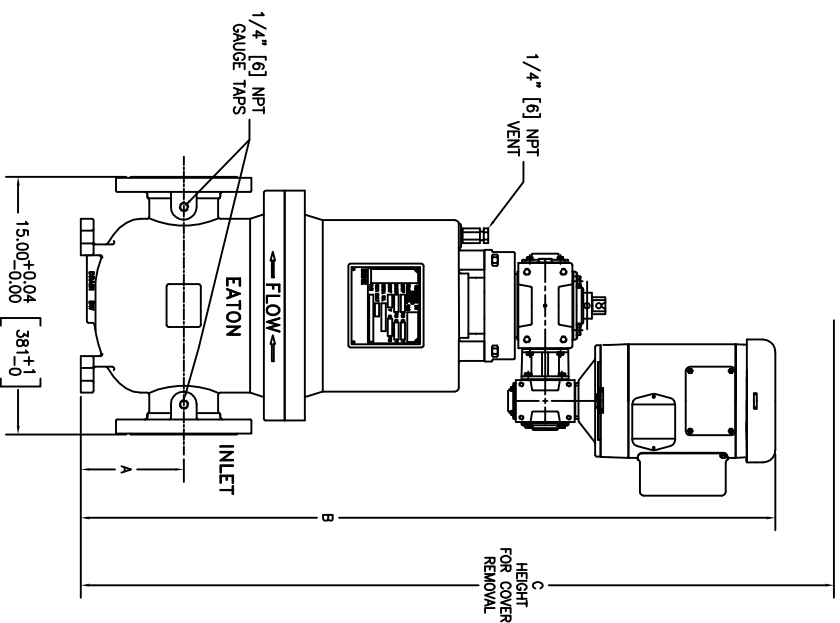
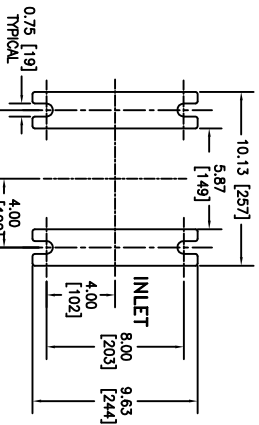

ELECTRONIC FILE NAME: SD2596CC3.DWG  
REF. EOR D394 DATE 05/17/06

UNAUTHORIZED USE, MANUFACTURE OR REPRODUCTION IN WHOLE OR IN PART IS PROHIBITED. DRAWING, DESIGN AND OTHER DISCLOSURES PROPERTY OF EATON FILTRATION, LLC

<b>EATON</b> 900 PARKMOUNT AVENUE, ELIZABETH, NEW JERSEY 07207		<b>EATON FILTRATION, LLC</b> MODEL 2596 AUTOMATIC STRAINER 150 ANSI CLASS RF FLANGE CAST STL SIZES 2" (50 mm) THROUGH 4" (100 mm)	
CERTIFIED FOR: P.O. NO.: REG. NO.: QUOTE NO.: TAG NO.: NUMBER OF UNITS: STRAINING ELEMENT:	DRAWN: VAA DATE: 05/17/06 CHECKED: FM DATE: 05/17/06	SD2596CC3	REV: A