

PIPE SIZE (NOMINAL)	DIMENSIONS			WEIGHT			PART NUMBER
	A IN. MM.	B IN. MM.	C IN. MM.	COVER LB. KG.	DRY LB. KG.	WET LB. KG.	
2" (50mm)	6 / 153	40.50 / 1029	42.50 / 1080	156 / 71	302 / 137	356 / 162	25960200053
3" (75mm)	6 / 153	40.50 / 1029	42.50 / 1080	156 / 71	316 / 144	371 / 169	25960300053
4" (100mm)	7 / 178	42 / 1067	44 / 1118	156 / 71	324 / 147	384 / 175	25960400053

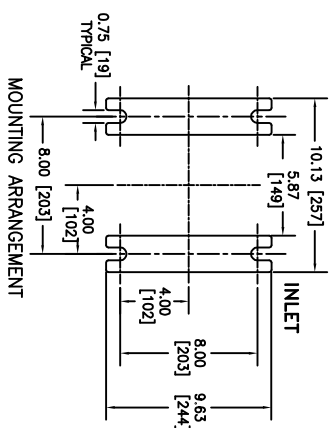
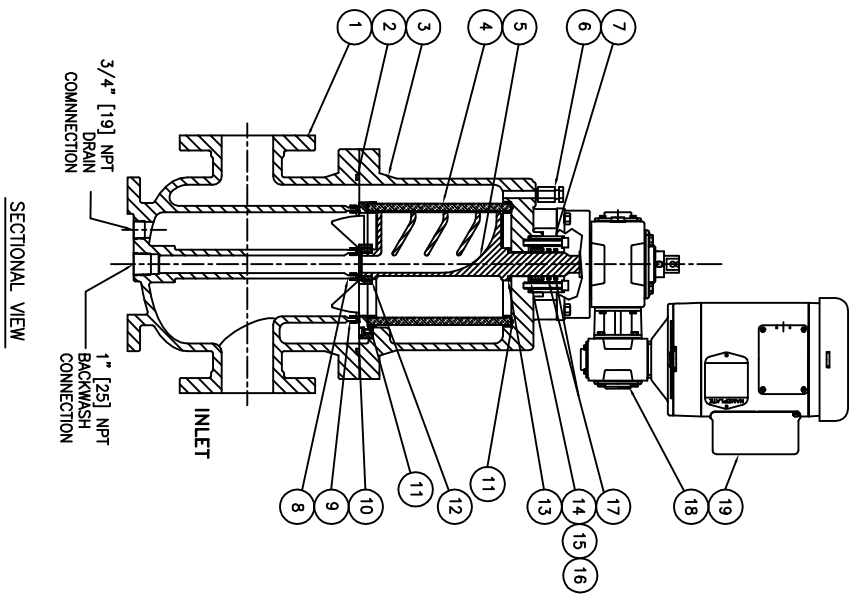
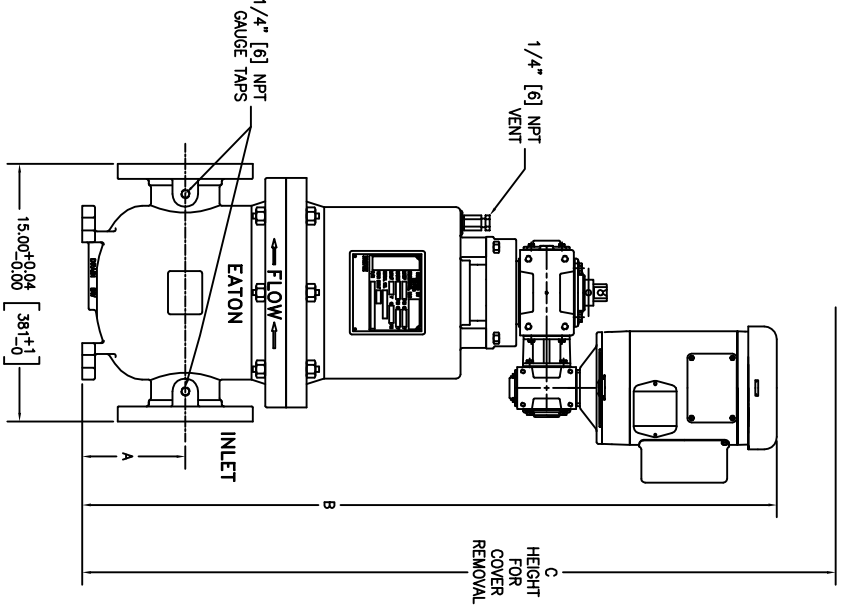

NO.	PART NAME	MATERIAL
1	BODY	A278 CL.30
2	COVER	A278 CL.30
3	CENPELLER SUPPORT	316 STAINLESS STEEL
4	STRAINING ELEMENT	316 STAINLESS STEEL
5	BACKWASH ARM-SHAFT	316 STAINLESS STEEL
6	VENT	BRASS
7	IDL™ HOUSING	316 STAINLESS STEEL
8	INNER SEAL	BUA-N
9	OUTER SEAL	BUA-N
10	GIRTH O-RING	BUA-N
11	ELEMENT O-RING	BUA-N
12	LOWER BUSHING	COMPOSITE
13	SHAFT WASHER	NYLON
14	SHAFT GASKET	BUA-N
15	UPPER BUSHING RING	TEFLON
16	UPPER BUSHING	COMPOSITE
17	SHAFT SEAL RINGS	BUA-N
18	GEAR REDUCER	CAST IRON
19	MOTOR	1/4 HP

- NOTES:
1. ALL FLANGE CONNECTIONS PER ASME/ASTM B16.1.
 2. FOR REPLACEMENT PARTS, MODEL NO., SIZE AND SERIAL NUMBER FROM THE STRAINER NAMEPLATE MUST BE FURNISHED.
 3. DESIGN PRESSURE: 200 PSI @ 150° F [13.8 BAR @ 65.5° C]

CERTIFIED FOR:
P.O. NO.:
REG. NO.:
QUOTE NO.:
TAG NO.:
NUMBER OF UNITS:
STRAINING ELEMENT:

EATON FILTRATION, LLC
900 PARKWAY AVENUE, ELIZABETH, NEW JERSEY 07207

MODEL 2596 AUTOMATIC STRAINER
125 ANSI CLASS FF FLANGE CAST IRON
SIZES 2" (50 mm) THROUGH 4" (100 mm)

DRWNO	VAA	DATE	05/17/06	CRST	FL	DATE	05/17/06
SIZE	NO	DATE	05/17/06	REV			
SD2596C1							

UNAUTHORIZED USE, MANUFACTURE OR REPRODUCTION IN WHOLE OR IN PART IS PROHIBITED. DRAWING, DESIGN AND OTHER DISCLOSURES PROPERTY OF EATON FILTRATION, LLC

ELECTRONIC FILE NAME: SD2596C1.DWG
REF. EOR 0800413 DATE 10/9/08