

## Automatic Self-Cleaning Strainers

# 2596 10"-16"

Pipeline  
Strainer

Cast  
Construction

Permanent  
Media



Model 2596 10"

*Eaton's Model 2596 Automatic Self-cleaning Cast Pipeline Strainers are available in 10", 12", 14" and 16" sizes. The Model 2596 is recognized across industries for its continuous flow, simplified maintenance, and worry-free operation.*

### FEATURES / BENEFITS

- Flow rates up to 6500 gpm (1476 m<sup>3</sup>/hr)
- A broad selection of screen options
- Automatic backwashing for operator-free service and minimal backwash effluent
- Exclusive idL™ Seal for leak free service
- Unitized modular assembly for easy maintenance
- Cast ductile iron construction

The Eaton Model 2596 Automatic Self-Cleaning Strainer is designed for the continuous removal of entrained solids from liquids in pipeline systems.

With an automated control system monitoring the strainer operation, cleaning is accomplished by an integral backwash system. A small portion of the screen element is isolated and cleaned by reverse flow while the remaining screen area continues to strain—providing uninterrupted flow. This efficient design uses only a small amount of the liquid being strained to carry debris away from the strainer element.

The Model 2596 features the idL™ shaft seal that positively prevents leakage from the backwash shaft at the top of the strainer. This unique quad seal keeps the exterior of the strainer dry and prevents external leakage or weeping of the process media down the sides of the strainer.

To simplify maintenance the Model 2596 features a unitized modular assembly. The motor, gear reducer, and the internal operating mechanism are all housed within the strainer cover and lift off as a unit. This makes all components easily accessible and reduces associated maintenance costs.

# EATON

Powering Business Worldwide

# Model 2596 10" to 16" Automatic Self-Cleaning Strainers

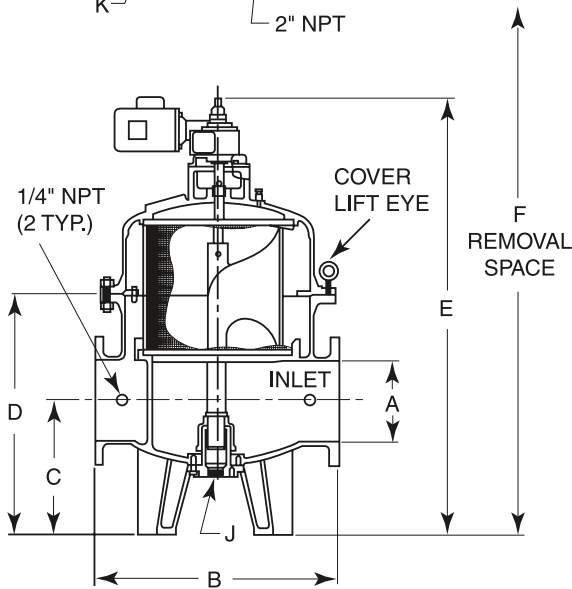
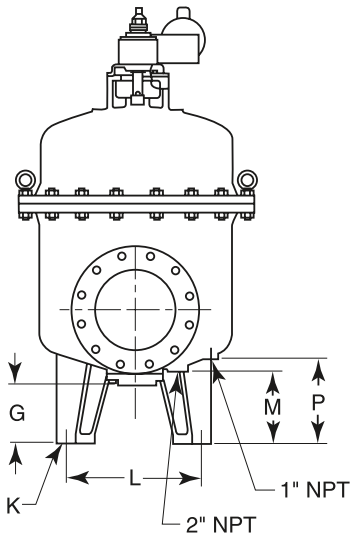

Model 2596 10" - 16" Flow Rates

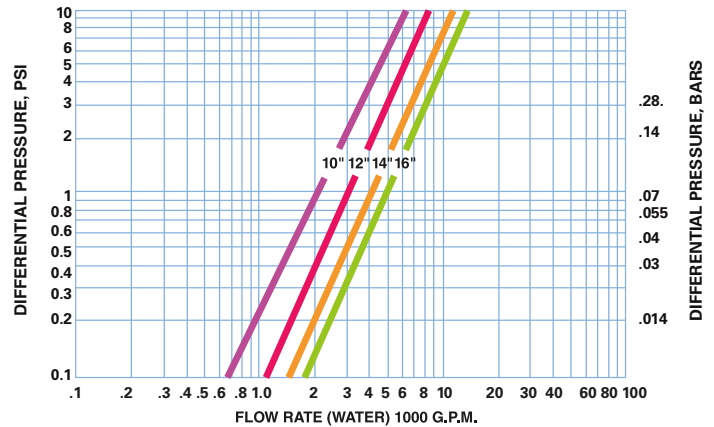

Pressure drop data indicates results to be expected with clean water, under normal flows with standard straining media and in clean strainer.

### Application Limits

- Ductile Iron Class 125 Flange (-20° to 150°F) 150 psi

### Application Limit 16" Size

- Ductile Iron Class 125 Flange (-20° to 150°F) 150 psi Based on ASME Section VIII, Div. 1. Lower pressure ratings at higher temperatures

Approximate Dimensions (inches)												Approximate Weight (lb)		
A	B	C	D	E	F	G	J	K	M	P	L	Dry	Wet	Cover
10"	38 1/4	19 3/4	35 3/4	64 3/4	90	8 9/16	2	7/8	10 11/16	12 1/2	24 1/2	1,840	2,615	705
12"	36 1/4	19 3/4	35 3/4	64 3/4	90	8 9/16	2	7/8	10 11/16	12 1/2	24 1/2	1,880	2,675	705
14"	44	22 1/16	42 5/16	76 1/2	112	8 9/16	2	7/8	10 7/8	13 1/2	29 5/8	2,810	4,360	1,050
16"	44	22 1/2	42 5/16	76 1/2	112	8 9/16	2	7/8	10 7/8	13 1/2	29 5/8	2,850	4,400	1,050

**North America**  
44 Apple Street  
Tinton Falls, NJ 07724  
Toll Free: 800 656-3344  
(North America only)  
Tel: +1 732 212-4700

**Europe/Africa/Middle East**  
Auf der Heide 2  
53947 Nettersheim, Germany  
Tel: +49 2486 809-0

Friedensstraße 41  
68804 Altlußheim, Germany  
Tel: +49 6205 2094-0

An den Nahewiesen 24  
55450 Langenlonsheim, Germany  
Tel: +49 6704 204-0

**China**  
No. 3, Lane 280,  
Linhong Road  
Changning District, 200335  
Shanghai, P.R. China  
Tel: +86 21 5200-0099

**Singapore**  
100G Pasir Panjang Road #07-08  
Singapore 118523  
Tel: +65 6825-1668

**Brazil**  
Av. Ermanno Marchetti, 1435 -  
Água Branca, São Paulo - SP,  
05038-001, Brésil  
Tel: +55 11 3616-8461

For more information, please  
email us at [filtration@eaton.com](mailto:filtration@eaton.com)  
or visit [www.eaton.com/filtration](http://www.eaton.com/filtration)

© 2019 Eaton. All rights reserved. All trademarks and registered trademarks are the property of their respective owners. All information and recommendations appearing in this brochure concerning the use of products described herein are based on tests believed to be reliable. However, it is the user's responsibility to determine the suitability for his own use of such products. Since the actual use by others is beyond our control, no guarantee, expressed or implied, is made by Eaton as to the effects of such use or the results to be obtained. Eaton assumes no liability arising out of the use by others of such products. Nor is the information herein to be construed as absolutely complete, since additional information may be necessary or desirable when particular or exceptional conditions or circumstances exist or because of applicable laws or government regulations.

US  
05-2019