

Read all instructions prior to installing and operating the equipment.
Failure to comply with these instructions could result in bodily injury or property damage.

TABLE OF CONTENTS

Introduction 1
 Receiving, Handling, and Inspection 2
 Storage 2
Installation 2
 Start Up 3
 Operation 4
 Shut Down Periods 4
 Standard Maintenance 4
Standard Maintenance 4
 Reducer Maintenance 5
 Manual Operation of Backwash Arm 6
Disassembly and Parts Replacement 6
 Removal of Cover and Operating Mech. Assembly..... 6
 Reassembly of Cover and Operating Mech. Assembly. 6
 Motor Replacement 7
 Shaft Packing Replacement 7
 Replacement or Maintenance of Filter Element and
 Backwashing Arm Bushing 7
 Reducer Replacement 8
 Removal of Orifice Plate..... 8
 Pilot Bushing and Housing Replacement..... 8
Trouble Shooting 9
Recommended Spare Parts 9
idL™ Shaft Seal Replacement 14



INTRODUCTION

The Eaton Model 2596 Self-Cleaning Strainers are devices installed in a pipeline to remove dirt and other unwanted debris from fluids. Straining is accomplished by directing the fluid through sized openings in Durawedge®, perforated, or mesh straining elements.

For additional information regarding Model 2596 Self-Cleaning Strainer visit our website at eaton.com/filtration

RECEIVING, HANDLING, AND INSPECTION

Prior to shipment, strainers are coated internally and on external machined surfaces to protect against rust. All openings are covered and the motor-reducer unit wrapped with plastic and secured with waterproof tape. The motor is packed separately.

1. Unpack the strainer and inspect for damage occurring during transit. Report damage to the carrier. If the strainer is not installed immediately, see "Storage" instructions.
2. Remove preservatives with solvent-dampened cloths. Exercise care when using solvent.
3. Verify the rated pressure and temperature on the strainer nameplate is not less than the maximum pressure and temperature of the system.
4. The rated pressure shown on the nameplate is the maximum pressure, including shock, at which the strainer may be operated
5. Check to be sure the available electrical power matches the voltage, phase and cycle requirements of the strainer motor and automatic control panel.
6. Remove flange and thread protectors. Check for and remove any foreign or loose materials such as blocking, desiccant bags, etc. that could be carried downstream when fluid is introduced into the strainer.

STORAGE

Whenever possible, store strainers indoors in a clean, dry environment. Replace all protective wrappings, flange protectors, plugs, etc. which may have been removed during receiving inspection.

Outdoor storage, if unavoidable, requires special treatment.

- a. Place a bag of silica-gel or similar desiccant in each strainer to absorb moisture (attach to inside of flange protectors).
- b. Reapply rust preventative to any machined surface which became exposed due to handling and/or receiving inspection.
- c. Make sure all openings are covered. Seal flange protectors with waterproof tape.

- d. Wrap motor-reducer unit with plastic and secure with tape. Permit air circulation or provide adequate desiccant for moisture control.
- e. Protect the entire strainer with heavy polyethylene wrap and seal with waterproof tape.



CAUTION: Before strainers are put into operation after storage be sure to remove all desiccants, protective bags, caps, plugs, etc. Inspect gasketing and shaft seals for possible deterioration and replace as required. Inspect oil level in reducer and check lubricant for accumulated condensation.

INSTALLATION

Position the strainer in the line so that the fluid enters the connection marked inlet.



CAUTION: Any alteration to the piping between the pump and the strainer could affect the performance of the unit. Lift strainer with slings under the inlet and outlet connection.

Be sure sufficient headroom is provided for easy removal of the internal parts. Refer to sales drawing for removal clearance.



NOTE: Clearance for rigging equipment must also be considered.

Support the strainer in the line as follows:

Both cast and fabricated strainers are provided with mounting feet. The footpads are drilled to accommodate the use of anchor bolts. Place the strainer in the line on concrete or steel mounts. Do not support the strainer or the piping coming to and from the strainer by the line flanges and flange bolting. See Fig 1(cast) or Fig 5 (fabricated) and sales drawing.

Connect the strainer to the line. Use the same type flange faces. For example, do not bolt raised face flanges to iron flat face flanges. Iron flanges must be flat face with full face gaskets.

Strainers are subject to fact-to-face variations due to machining and fabrication tolerances. Prefabricated piping systems must allow adjustment at the strainer connections.

Be sure flange gaskets are in place and fasteners are tight.

Inspect all external components of the operating mechanism for damage due to handling and shipping. Manually rotate the backwash arm to observe proper alignment.

To operate manually and determine freedom of movement, see "Manual Operation of Backwash Arm", page 6. If backwash arm rotates freely proceed with installation.

If binding occurs, follow "Removal of Cover and Operating Mechanism Assembly" procedures contained on page 6 and rectify cause of binding.

Follow "Reassembly of Cover and Operating Mechanism Assembly" procedure on page 6. Then proceed with installation.

For Fabricated Strainers:

Attach the blow-off/drain line to the NPT coupling in the center of the bottom head. See Figure 1. Install a ball, gate or plug valve in this line. Keep this valve closed except when necessary to drain the strainer or blow-off debris settled on the bottom.

Attach the backwash line to the side flanged opening. It is important to prevent backpressure by having a short, free flowing backwash line with no vertical risers and a minimum of bends.

For Cast Strainers:

Attach the chamber drain line to the 1" NPT threaded opening on the outer edge of the filter. See Fig 1.

Attach the blow-off drain line to the offset 2" NPT opening. See Fig 1. Install a manually operated ball, gate or plug valve in this line. Keep this valve closed except when necessary to drain the strainer or blow off debris settled on the bottom.

Attach the backwash line to the center 2" NPT or 2" 150# ANSI flanged opening. It is important to prevent back pressure by having a short, free flowing backwash line with no vertical risers and a minimum of bends.

Install a backwash control valve in this line. The valve may be manually or automatically operated. It is recommended that it be used only for full-on/full-off control except for high pressure or mesh screen applications in which the backwash control and/or throttling valve should be adjusted to a flow rate which attains thorough cleaning only.

Connect power source to the strainer motor. Note: It is advisable to use flexible power cable with extra length to allow for strainer cover removal without having to disconnect the motor.



CAUTION: Be sure power source matches motor requirements. Damage may occur if improperly connected. Motor starter should incorporate a thermal overload device to protect the motor.

Interlock strainer motor with process fluid service pump where feasible. Install a fusible disconnect or circuit breaker on the incoming power service.

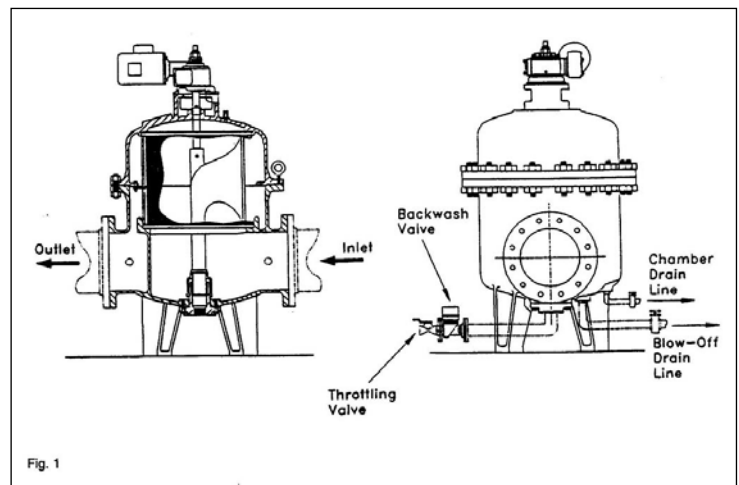

START-UP

Check the reducer for lubricant. Fill unit to pipe plug level with proper oil if level is low. See "Reducer Maintenance" section on page 5.

Install or open reducer vent which has been plugged to prevent lubricant loss during shipment. Loosen packing gland nuts. Energize strainer motor and/or controls. Open vent on strainer cover. Slowly introduce fluid to be strained.



CAUTION: The initial start-up should be done while in the continuous backwash mode. Once the system has been purged of all initial construction debris, the automatic mode can be activated. The thordon bearing is lubricated by liquid to be strained. DO NOT operate for long periods before strainer is filled with fluid. Do not over tighten the packing gland nuts.

Close strainer vent when air is expelled and fluid begins to flow.



NOTE: Good operating practice dictates that the operator observes the strainer carefully for several weeks to determine the best operating mode, that is, continuous or intermittent backwash. Refer to “Self-Cleaning Strainer Control Panel Instructions” provided with such equipment.

OPERATION

Operate the strainer in the continuous mode only, unless controls for intermittent operation have been provided and energized.

Normally the drain valve is left in the closed position. Approximately once each week adjust this valve to the full open position for two to three minutes to remove any settled debris on the strainer bottom. Frequency of this operation is dependent upon the type and amount of entrained solids in the liquid.

Take daily readings of the pressure drop across the strainer to ensure proper operation.



CAUTION: Total pressure drop in excess of 15 psig is a warning signal requiring investigation and corrective action. Permanent damage may result if operated in excess of 15 psig.

IF THIS SHOULD OCCUR: Check strainer to be sure that backwash arm is rotating (if not see section on Trouble Shooting, page 9).

Check backwash line for restrictions. Valves in this line should be opened full except for high pressure or mesh screen applications in which the backwash control and/or throttling valve should be adjusted to a flow rate which attains thorough cleaning only.

Position blow-off/drain valve to the full open position for two to three minutes to clear the strainer of accumulated debris. Adjust the timer, in the control panel to increase the duration of the backwash.

Should the pressure drop still remain above normal when the backwash is operating, close the outlet valve and open the backwash valve full for several minutes. If upon resuming flow thru the unit, the pressure drop is not normal, the strainer should be shut down.

NORMAL SHUT-DOWN

When necessary to shut-down the system:

1. Backwash the strainer for at least six minutes to clean the straining elements.
2. Close the main flow valves fully open the blow-off/drain valve and the vent on the strainer cover. The chamber drain valve should also be fully opened.
3. De-energize strainer motor and/or controls.
4. Follow standard maintenance procedures contained herein. Do not allow the straining elements to dry while dirty.

EMERGENCY SHUT-DOWN

1. To quickly shut-down the system, close the main inlet and outlet flow valves.
2. Open the blow-off/drain valve “full” and open the vent on the cover. Open the chamber drain valve.
3. De-energize strainer motor and/or controls.
4. Follow standard maintenance procedures as soon as possible. Do not allow the straining elements to dry while dirty.

STANDARD MAINTENANCE

INTERNALS

At normal plant intervals, the strainer should be disassembled for internal inspection (refer to “Normal Shut-Down” procedures, page 4).

Follow “Removal of Cover and Operating Mechanism Assembly” procedures, page 6.

Inspect assembly for damage or deterioration due to normal operation. Examine straining element and check for mechanical damage or blinding.

Clean straining element thoroughly.



NOTE: It is not necessary to remove the straining element. Cleaning by scrubbing the straining element with a bristle brush or spraying with a high pressure hose. If necessary, the straining element may be steam cleaned.

REDUCER MAINTENANCE

After the initial 250 hours of operation, drain the reducer oil while warm and flush the case with a light flushing oil. Refill to the proper level with the appropriate lubricant (use Mobil Cylinder Oil 600W or equal).

Check the level at 500 hour intervals, drain and refill at 2500 hour intervals, or every six months, whichever occurs first. Check both housings on double reduction reducers.

For operation in the 15° to 60° F range use a lubricant conforming to AGMA Specification No. 7 compound. For 50° to 100° F operation use AGMA Specification No. 8 compound. Grease lubricated bearings should be lubricated at 500 hour intervals with Mobilux Grease #2 or equal.

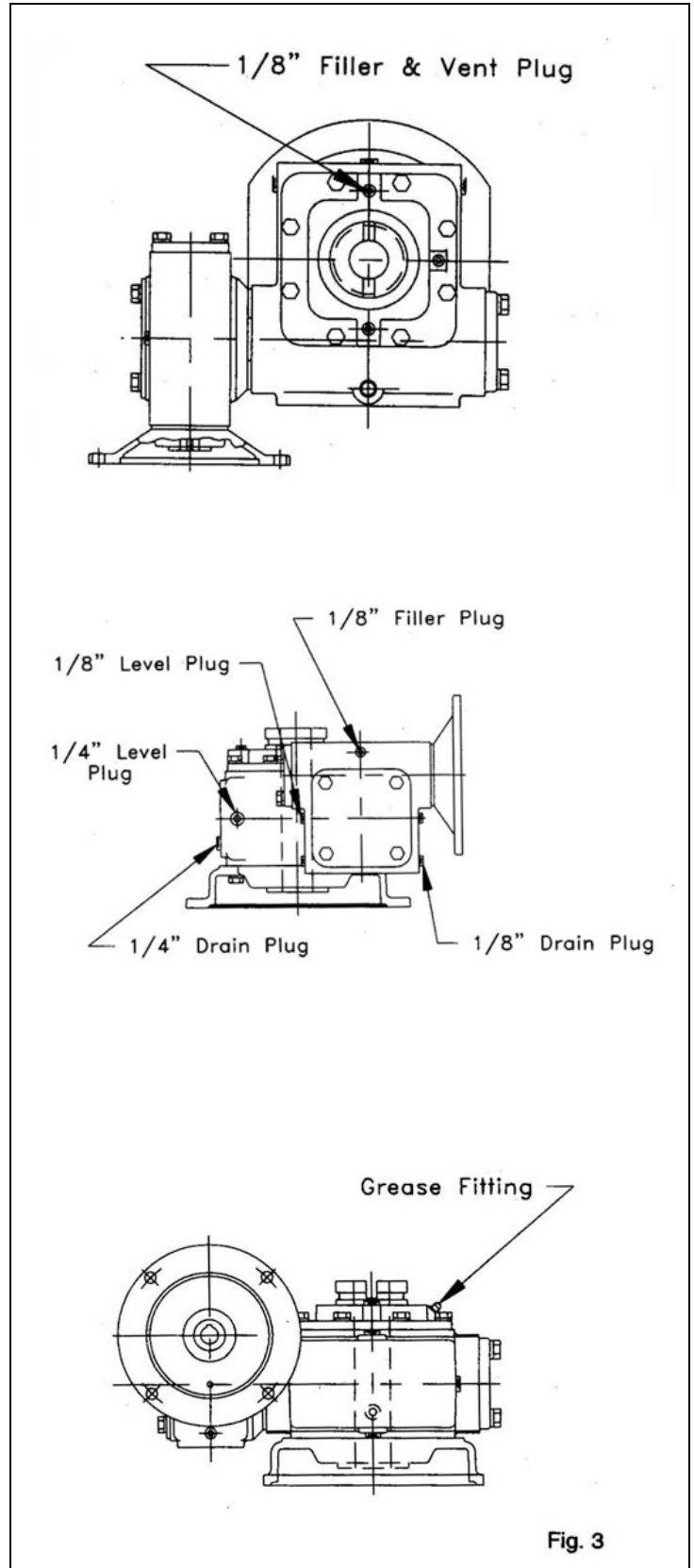
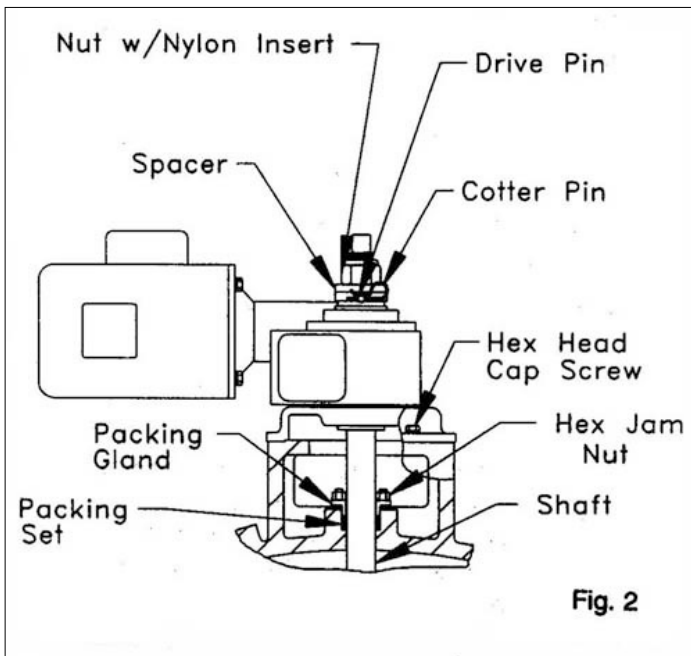

MANUAL OPERATION OF BACKWASH ARM

The Model 2596 is furnished with a removable drive key to facilitate manual operation.

1. De-energize the power supply to the strainer motor. Remove the hair cotter pin and tap out drive pin from shaft (see Fig 2).
2. Hold shaft flat with adjustable wrench and back off the lock nut 1/2 turn.
3. The backwash can now be rotated manually. Manually open the backwash control valve (manual cleaning only).
4. Place a wrench on the flats at the top of the shaft and rotate the backwash arm at approximately 5 RPM as often as required to maintain a low pressure drop (manual cleaning only). One turn minimum for pre-startup.
5. To return the strainer to normal operation first close the backwash control valve (manual cleaning only).
6. Align the cross hole in the B/W shaft with gear reducer by rotating the drive shaft.
7. Insert drive pin in B/W arm shaft and secure with hair cotter pin.
8. Tighten lock nut.
9. Energize the power supply to the strainer drive motor.

The strainer is now ready for operation.

DISASSEMBLY & PARTS REPLACEMENT PROCEDURES

The Model 2596 may be disassembled entirely without removal from the pipeline to permit examination or replacement of any individual part. Refer to this manual and the included assembly drawings for the location of parts.



CAUTION: Do not perform any maintenance on this strainer until normal shut down procedures have been performed.

REMOVAL OF COVER AND OPERATING MECHANISM ASSEMBLY

This assembly can be removed as a complete unit. Refer to "Normal Shut-Down" procedures.



NOTE: To ensure ease of assembly and avoid damage to element, all legs of sling must be of equal length.

1. Disconnect power source and remove fuses.
2. Disconnect electrical connections to the motor.
3. Remove the cover nuts on cast strainers or loosen swing bolt nuts and swing bolts to clear blocks on fabricated strainers.
4. Lift the cover assembly gently, using the cover lifting lugs on fabricated strainers or the cover lifting eyes on cast strainers. These lifting lugs/eyes are for the cover assembly. Note: See "Installation" procedures to lift strainer.
5. All internal parts may now be inspected for deterioration, wear or blockage and replaced or repaired as necessary. Inspection should include the element and bushing. The replacement procedures for the reducer, motor and filter are contained herein.

REASSEMBLY OF COVER AND OPERATING MECHANISM ASSEMBLY

Examine cover O-ring seal and replace O-ring if necessary. Refer to "Replacement or Maintenance of Filter Element on Page 7.



CAUTION: Do not use excessive force on the backwash arm. Disconnecting the shaft from the reducer also disconnects the shaft from the protection of the motor overloads. If excessive resistance is met, rotate in the opposite direction to dislodge any wedged debris. If this does not work, the cover must be removed and the source of blockage cleared away.

MOTOR REPLACEMENT

(Refer to "Normal Shut-Down" procedure)

1. Disconnect power source and remove fuses.
2. Disconnect motor leads.
3. Remove bolts holding the motor to the reducer.



CAUTION: Do not allow the motor to drop, or its weight to rest, on the output shaft.

4. Remove the key from the motor output shaft.
5. Install the key on the new motor, install the new motor on the reducer and secure with motor mounting cap screws.
6. Reconnect the motor leads. (Direction of rotation is not important).
7. Replace fuses and connect power.

SHAFT PACKING REPLACEMENT

(SEE IDL SHAFT SEAL INSTRUCTIONS)

REPLACEMENT OR MAINTENANCE OF ELEMENT & BACKWASH ARM BUSHING

(See Figs 5 & 6, pages 10 & 11 for fabricated strainers or Figs 7 & 8 pages 12 & 13 for cast strainers) The Model 2596 is furnished with a removable element secured to a support ring by four roll pins. The support ring is secured to the cover by four bolts, washers and locknuts.

Refer to "Removal of Cover and Operating Mechanism Assembly", page 6.

Fabricated Strainers

Lift the cover assembly from the body and lower cover assembly to supports placed under support ring. Remove the four bolts between the support ring and cover, then lift the cover assembly. See Fig 4

Inspect the element, sealing surfaces and bushing located at bottom of backwash arm. Clean element and sealing surfaces as required. Remove existing element by removing the roll pins.

Replace element by aligning the element tab holes with the support ring holes and replace the roll pins. Replace backwash arm bushing as required.

Lower the cover and backwash arm assembly into the center of the support ring/element assembly. Secure cover to support ring with bolts, washers, and locknuts.

Lift cover assembly and place into body.

Cast Strainers

Lift the cover assembly from body. With two supports placed below the element, lower the assembly as close to the supports without touching, and then remove the four bolts allowing the element to rest on support horses. See Fig 4A.

Clean sealing faces in body and cover. Inspect gaskets and replace if necessary.

Lower cover assembly onto new or existing element until bolts and elastic stop nut can be fastened together. Tighten diagonally until element is firmly and evenly seated in cover. Replace stop nuts after 3 disassemblies.

Lift cover, B/W assembly and filter and place into body. Once the B/W arm guide is properly seated on the bottom bearing housing, the cover flange will come into full contact with the body flange.

Figure 4

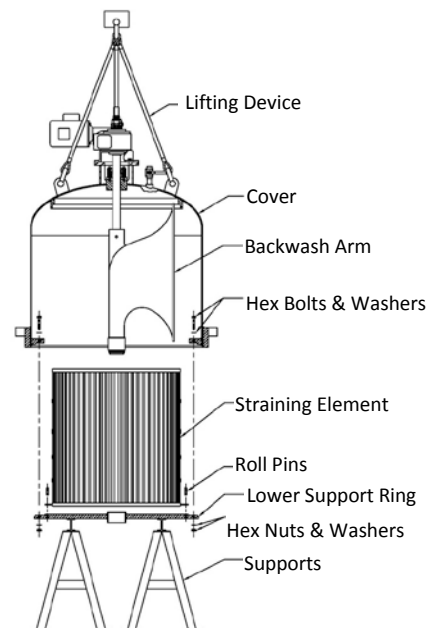
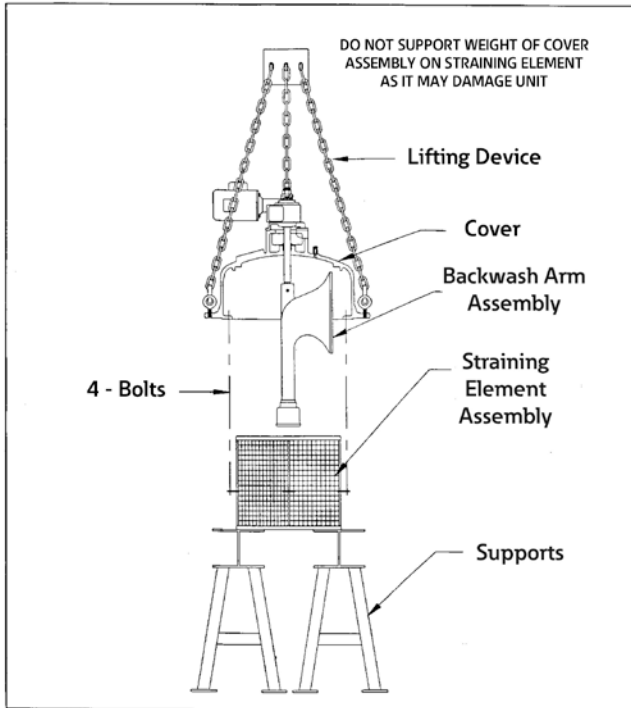

Fig 4A



Before tightening swing bolts, rotate manually to ensure freedom from binding. See "Manual Operation of Backwash Arm", page 6.

1. Align cover and body bolt blocks and secure with swing bolts.
2. Connect the electrical leads to the motor. Please note that the direction of rotation is not important.
3. Install fuses and connect power source.
4. The unit is now ready for operation.

Refer to "Start-Up" procedures on page 3.

REDUCER REPLACEMENT (See Fig 3)

1. Disconnect power and remove motor leads. Remove motor flange bolts and washers and remove motor.



CAUTION: Do not permit the motor to drop or allow its weight to rest on the drive shaft.

2. Remove the hair cotter pin and tap out drive pin from the shaft (see Fig 2).

3. Remove the locknut and spacer.
4. Remove the cap screws and washers securing the reducer to the reducer mount and remove the reducer.
5. Position the new reducer in place with input shaft parallel and opposite the strainer inlet nozzle. Secure with fasteners.
6. Replace spacer and locknut. Tighten locknut until step on backwash arm shaft is in contact with the sleeve of the reducer.

Follow Manual Operation of Backwash Arm, page 6.

REMOVAL OF ORIFICE PLATE (IF APPLICABLE)



NOTE: Certain applications may use an orifice plate on backwash arm.

The orifice plate can be removed with the backwash arm and filter element in place by removing the screws attaching the orifice plate to the backwash arm then sliding the orifice plate out.

PILOT BUSHING & HOUSING REPLACEMENT

Cast Strainers Only:

To replace the pilot bushing:

1. Disconnect the power to strainer drive motor. Isolate the strainer then drain inner chamber.
2. Disconnect and remove part of the backwash line to allow removal of bushing housing.
3. Remove 3/4 cap screws (4 or 8) and drop guide bushing. This can be done with backwash arm in place if necessary.
4. Old guide bushing can be removed by cutting or drawn out with an extractor tool. Care must be taken not to damage housing wall.
5. After cleaning, insert new guide bushing using a wood block to tap it into housing.
6. Before replacing the guide bushing assembly, check the O-ring seal and replace if necessary.

TROUBLE SHOOTING

High Differential Pressure

1. High solids loading in process fluid
 - A. Increase length of backwash cycle.
 - B. Backwash continuously.
2. Piping
 - A. Shorten backwash line, eliminate elbows, upward pipe runs, restrictions due to valves, etc.
3. Backwash arm not rotating
 - A. Motor overloads tripped
 1. Obstruction between straining element and backwash arm.
 2. Packing too tight.
 3. Bearing failure.
 - B. Motor/Reducer Failure
 1. Incorrect power applied to strainer motor.
 2. Overload heaters in motor starter improperly sized.
 3. Lubricant level in reducer too low.
 4. Reducer vent plugged.
4. Control problems
 - A. Blown fuses.
 - B. Incorrect power applied to control panel and/or valves, switches, etc. I
 - C. Incorrect wiring between control panel and valves, switches, alarms, etc.
 - D. Differential pressure switch improperly adjusted.
 - E. Insufficient air pressure applied to pneumatically operated backwash valves.

RECOMMENDED SPARE PARTS

Qty.	Description
1	O-Ring (Cover Seal)
1	Shaft Seal Kit
1	Pilot Bushing
2	Pin (B/W Arm Drive Pin)
1	Straining Element Assembly (with gaskets)
1	O-Ring (Bottom Bushing Housing) <i>(Cast Strainers Only)</i>

When ordering spare parts, be sure to specify all nameplate data as well as description and quantity of parts.

Figure 5

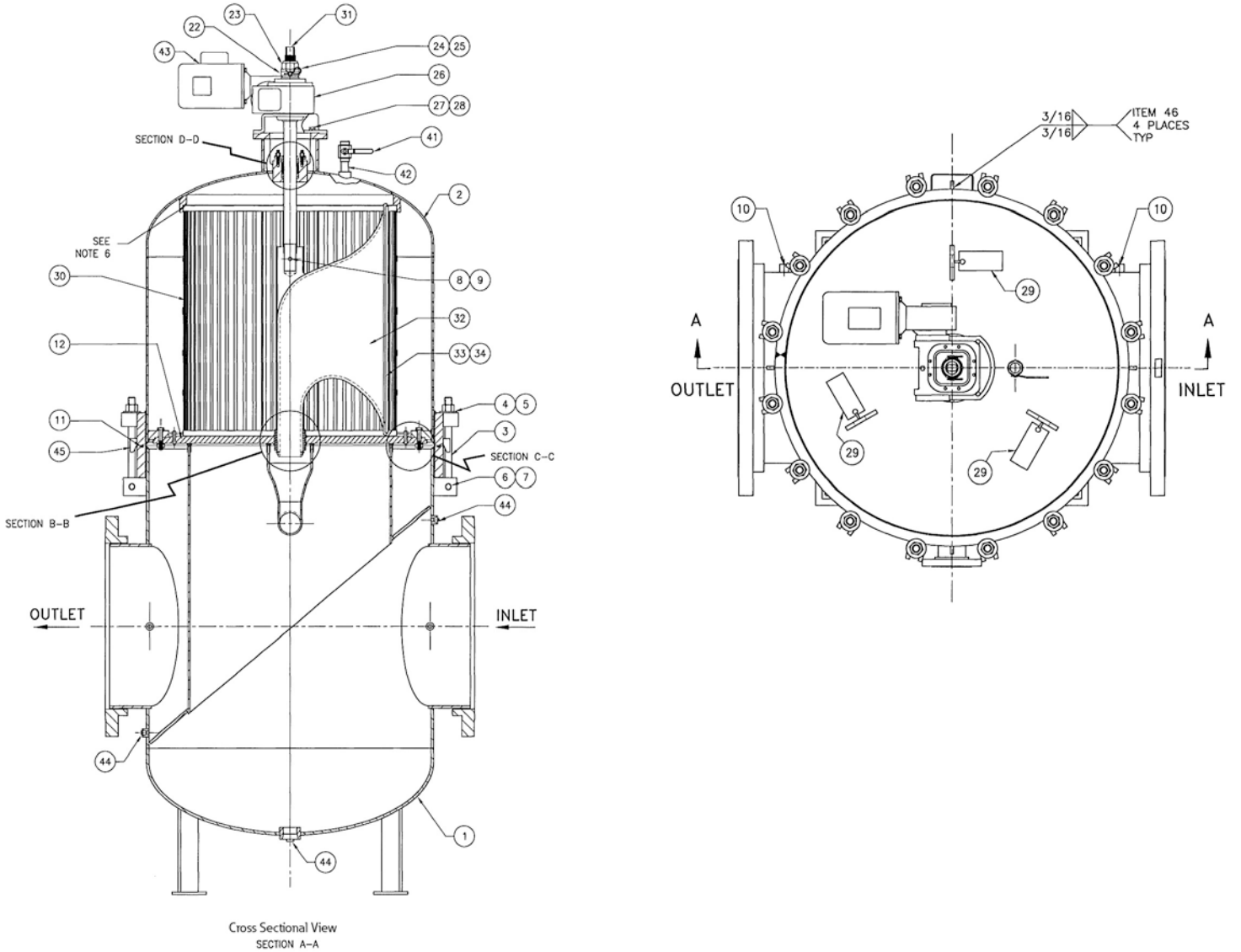
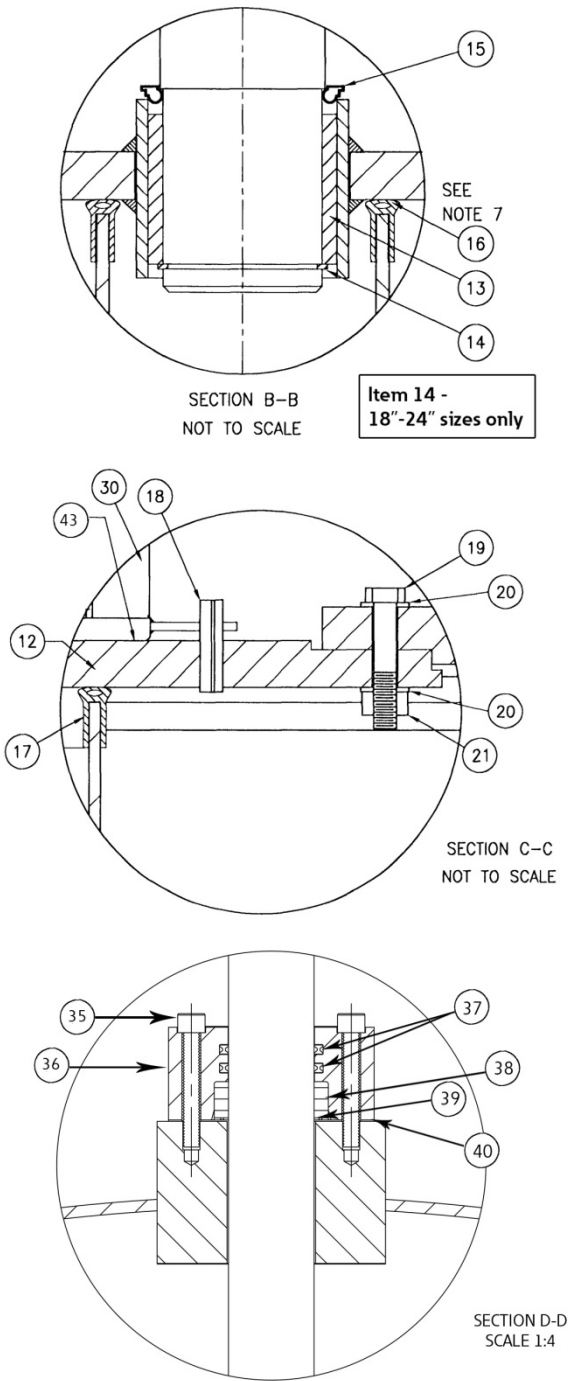

Figure 6



List of Materials

- 1 Body (1)
- 2 Cover (1)
- 3 Eye Bolt (16)
- 4 Hex Nut (16)
- 5 Washer (16)
- 6 Eye Bolt Pin (16)
- 7 Retaining Ring (32)
- 8 Nut for B/W Pin (2)
- 9 Pin B/W Arm (1)
- 10 Protector Cap (2)
- 11 O-Ring (Girth Cap) (1)
- 12 Support Ring (1)
- 13 B/W Arm Bushing (1)
- 14 Ring (1)
- 15 Grommet
- 16 Extrusion, Small Ring (1)
- 17 Extrusion, Large Ring(1)
- 18 Roll Pin (4)
- 19 Hex Head Cap Screw (4)
- 20 Washer (8)
- 21 Locknut (4)
- 22 Spacer (1)
- 23 Nut w/ Nylon Insert (1)
- 24 Drive Pin (1)
- 25 Cotter Pin (2)
- 26 Gear Reducer (1)
- 27 Hex Head Cap Screw (4)
- 28 Lock Washer (4)
- 29 No Lift Tag (3)
- 30 Element (1)
- 31 Backwash Shaft(1)
- 32 Backwash Arm (1)
- 33 B/W Arm Orifice Plate (1)
- 34 Screw (16)
- 35 Socket Head Cap Screws (4)
- 36 Bearing Housing (4)
- 37 Quad-Rings(1)
- 38 Bushing (1)
- 39 O-Ring (1)
- 40 Gland Gasket (1)
- 41 Ball Valve (1)
- 42 Nipple (1)
- 43 Marine Sealant (A/R)
- 44 Pipe Plug – 1/2" NPT (2)
- 45 Pipe Plug – 2" NPT (1)

Recommended Spare Parts

- 1 Pin B/W Arm (2)
- 2 O-Ring (Girth Flange) (1)
- 3 B/W Arm Bushing (1)
- 4 Element (1)
- 5 Shaft Seal Kit (1)
- 7 Marine Sealant (1)

Figure 7

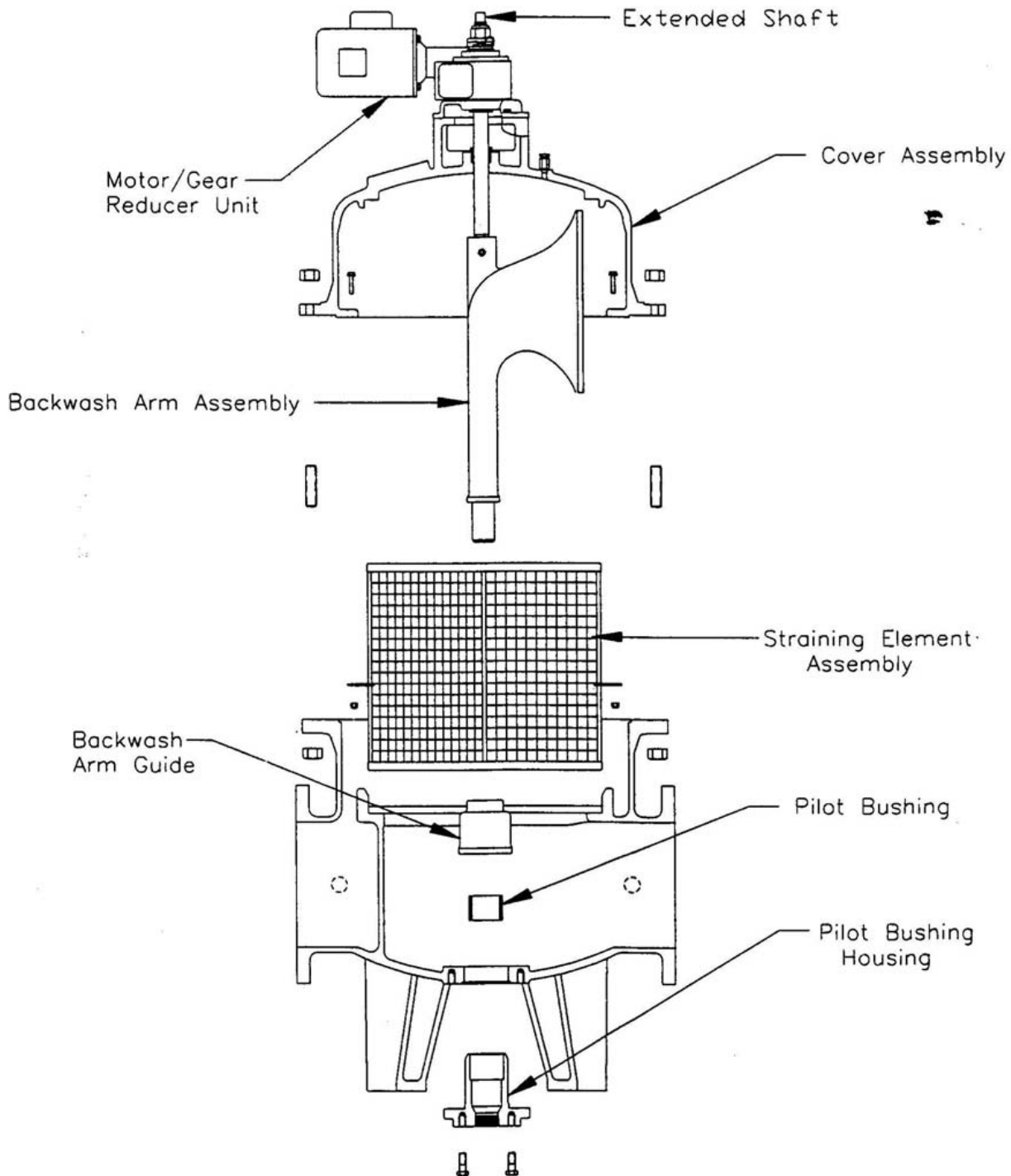
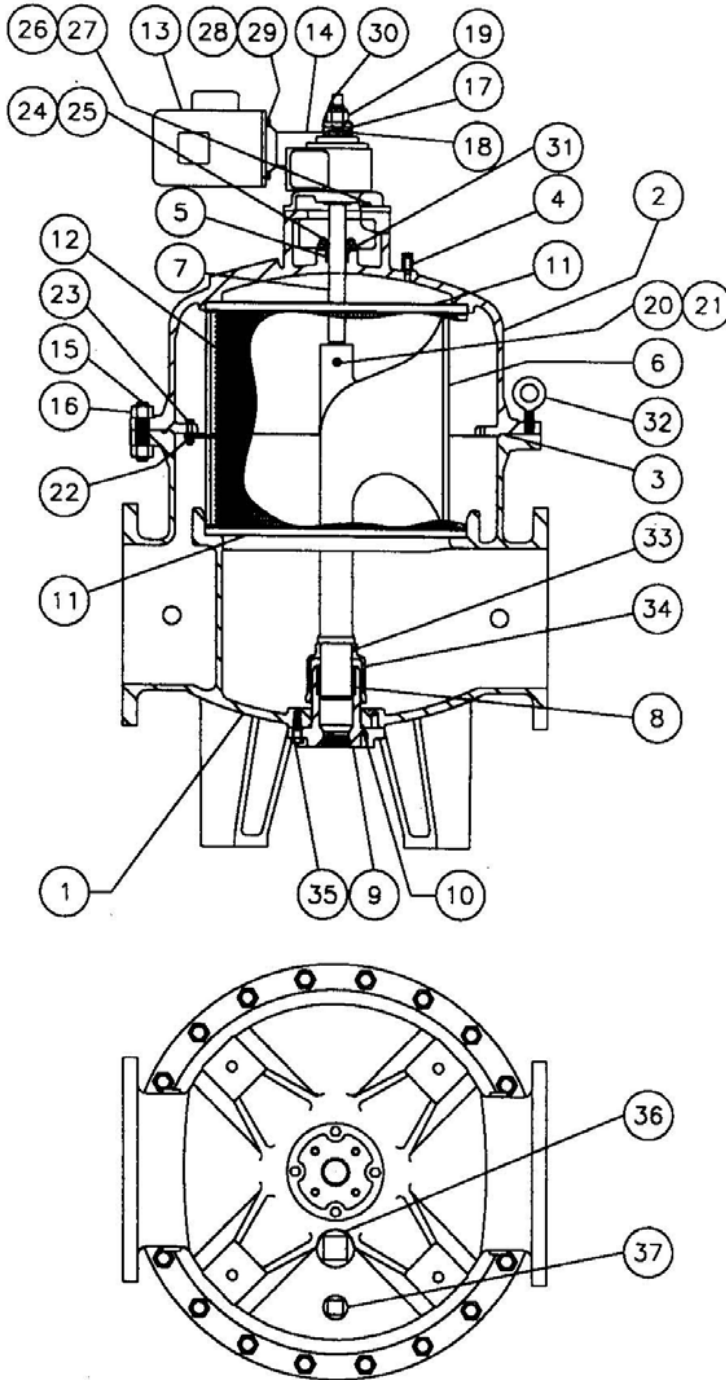



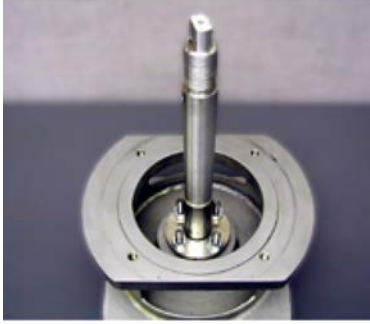





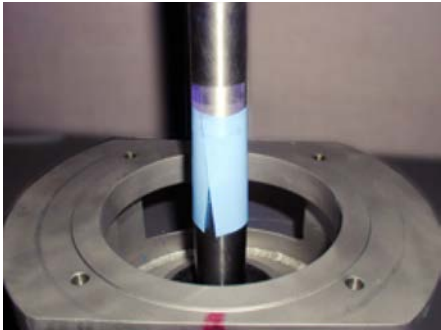

Figure 8



Parts List

1. Body (1)
2. Cover (1)
3. O-Ring (1)
4. Vent 1/4" NPT (1)
5. IDL Shaft Seal (1)
6. Backwash Arm (1)
7. Backwash Shaft (1)
8. Pilot Bushing (1)
9. Bushing Housing (1)
10. O-Ring (1)
11. Gasket (2)
12. Element (1)
13. Motor (1)
14. Gear Reducer (1)
15. Stud
16. Hex Nut
17. Cotter Pin (2)
18. Drive Pin (1)
19. Elastic Stop Nut (1)
20. Backwash Arm Pin (1)
21. Elastic Stop Nut (2)
22. Elastic Stop Nut (4)
23. Hex Head Cop Screw (4)
24. Stud (2)
25. Hex Jam Nut (2)
26. Hex Head Cop Screw (4)
27. Lock Washer (4)
28. Motor Mounting Bolt (4)
29. Lock Washer (4)
30. Spacer (1)
31. Packing Set (Obsolete)
32. Lifting Eye Bolt (4)
33. Set Screw (2)
34. Backwash Arm Guide (1)
35. Hex Head Cop Screw
36. 2" NPT Pipe Plug (1)
37. 1" NPT Pipe Plug (1)

ILLUSTRATION OF TYPICAL idL™ SHAFT SEAL REPLACEMENT

		
<p>Photo 1: Gear reducer (gray) mounted to cut away piece (silver) of the automatic strainer.</p>	<p>Photo 2: Internal view of the strainer with gear reducer removed and the backwash arm shaft and original packing and packing gland visible.</p>	<p>Photo 3: Internal view of the strainer with the original packing and packing gland removed.</p>
		
<p>Photo 4: The backwash arm shaft is cleaned with fine emery cloth.</p>	<p>Photo 5: The gasket seal is installed over the backwash arm shaft.</p>	<p>Photo 6: The quad ring seals and bushing on top of the idL™ bearing housing before assembly and installation.</p>
		
<p>Photo 7: The seals and bushing have been assembled into the idL™ bearing housing and the white PTFE O-ring is installed.</p>	<p>Photo 8: The blue plastic shim, taped and lubricated to the backwash arm, should just cover the shoulder and help ease the quad rings over the shoulder of the backwash arm shaft.</p>	<p>Photo 9: The completed idL™ bearing assembly is installed over the backwash arm shaft.</p>

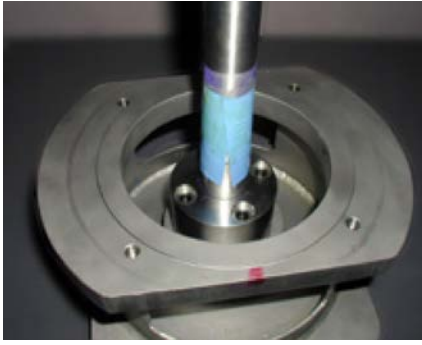

Photo 10: The idL™ bearing assembly in place.

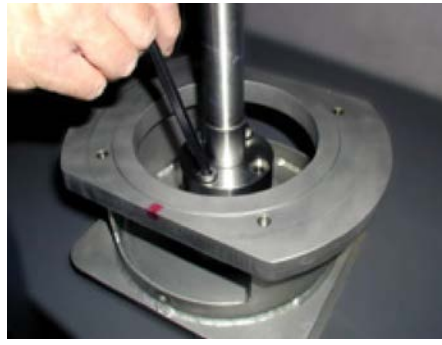

Photo 11: Two allen head cap screws hold the idL™ bearing seal in place.



Photo 12: After the idL™ bearing seal is in place, the gear reducer is replaced on the top of the strainer.

North America — HQ

44 Apple Street
Tinton Falls, NJ 07724

Toll Free: (800) 656-3344
(North America only)

Voice: +1 732 212-4700

Brazil

Av. Julia Gaioli, 474 – Bonsucesso
07251-500 – Guarulhos
Brazil

Voice: +55 11 2465 8822

Singapore

4 Loyang Lane #04-01/02
Singapore 508914

Voice: +65 6825 1668

For more information,
please e-mail us at
filtrationinfo@eaton.com
or call 732-212-4700.

Europe/Africa/Middle East

Auf der Heide 2
53947 Nettersheim, Germany

Voice: +49 2486 809 0

China

No.7, Lane 280, Linhong Road
Changning District,
Shanghai 200335, China

Voice: +86 21 5200 0422

WARRANTY

All products manufactured by Seller are warranted against defects in material and workmanship under normal use and service for which such products were designed for a period of eighteen (18) months after shipment from our factory or twelve (12) months after start-up, whichever comes first. OUR SOLE OBLIGATION UNDER THIS WARRANTY IS TO REPAIR OR REPLACE, AT OUR OPTION, ANY PRODUCT OR ANY PART OR PARTS THEREOF FOUND TO BE DEFECTIVE. SELLER MAKES NO OTHER REPRESENTATION OR WARRANTY, EXPRESS OR IMPLIED, INCLUDING, BUT NOT LIMITED TO, ANY IMPLIED WARRANTY OF MERCHANTABILITY OR FITNESS FOR A PARTICULAR PURPOSE. WE SHALL NOT BE LIABLE FOR CARTAGE, LABOR, CONSEQUENTIAL DAMAGES OR CONTINGENT LIABILITIES. OUR MAXIMUM LIABILITY SHALL NOT IN ANY EVENT EXCEED THE CONTRACT PRICE FOR THE PRODUCT.