

NO.	PART NAME	MATERIAL
1	BODY	DUCTILE IRON SA 395
2	COVER	DUCTILE IRON SA 395
3	ELEMENT	STAINLESS STEEL
4	BACKWASH ARM	DUCTILE IRON
5	GASKET	BUNA-N
6	VENT VALVE 1/4" BSPT	STAINLESS STEEL
7	COTTER PIN	STEEL
8	DRIVE PIN	STAINLESS STEEL
9	ELASTIC STOP NUT	STAINLESS STEEL
10	GEAR REDUCER	CAST IRON
11	MOTOR - 1/3 HP	UNIT SUPPLIED W/O MOTOR
12	QUAD SEAL	BUNA
13	BACKWASH SHAFT	STAINLESS STEEL
14	O-RING	BUNA-N
15	STUD	STEEL SA 193 GR.B7
16	HEX NUT	STEEL SA 194 GR.2H
17	PILOT BUSHING HOUSING	DUCTILE IRON SA 395
18	O-RING	BUNA-N
19	PILOT BUSHING	DELFIN
20	BACKWASH ARM GUIDE	DUCTILE IRON A 395
21	WASHER	STEEL

NOTES:

1. ALL FLANGE CONNECTIONS CONFORM TO BS4504 PN16.
2. FOR REPLACEMENT PARTS, MODEL NO., SIZE, AND SERIAL NO., FROM THE STRAINER NAMEPLATE MUST BE FURNISHED.
3. MAX. WORKING PRESSURE: 150 PSI @ 150° F (10.3 BAR @ 65.5° C)
4. WEIGHT: DRY-4325 LBS. (1966 KGS.)
WET-7100 LBS. (3227 KGS.)
5. COVER WEIGHT: 1660 LBS. (755 KGS.)
6. EXTERNAL COATING: ENG'G SPEC. ES-301

SECTION "A-A"

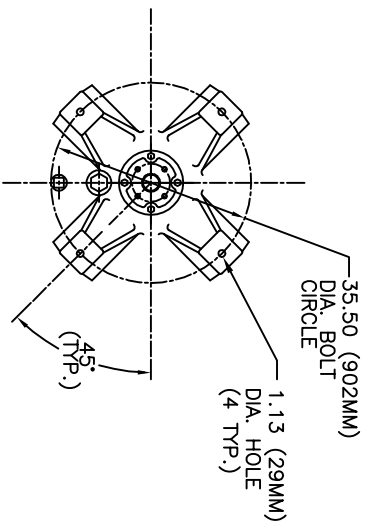

VIEW "B-B"
MOUNTING ARRANGEMENT

CERTIFIED FOR:
P.O. NO.:
REG. NO.:
QUOTE NO.:
TAG NO.:
STRAINING ELEMENT:

ELECTRONIC FILE NAME: SD259638.DWG
REF. ECR D507
DATE 11/1/05

UNAUTHORIZED USE, MANUFACTURE OR REPRODUCTION IN WHOLE OR IN PART IS PROHIBITED. DRAWING, DESIGN AND OTHER DISCLOSURES PROPERTY OF EATON FILTRATION, LLC

EATON	EATON FILTRATION, LLC	
	900 FAIRMOUNT AVENUE, ELIZABETH, NEW JERSEY 07207	
NAME	SIZE 450 MM (18")	MODEL 2596
SELF-CLEANING STRAINER - DUCTILE IRON		
BS4504 PN16 FF FLANGES		
DRAWN	VAA	DATE 10/8/97
SIZE	DWG	CERT. WB
A	NO	DATE 10/8/97
SD259638		REV
		C