

NO.	PART NAME	MATERIAL
1	BODY	DUCTILE IRON SA 395
2	COVER	DUCTILE IRON SA 395
3	ELEMENT	STAINLESS STEEL
4	BACKWASH ARM	DUCTILE IRON
5	GASKET	BUNA-N
6	VENT VALVE 1/4" BSPT	STAINLESS STEEL
7	COTTER PIN	302 STAINLESS STEEL
8	DRIVE PIN	304 STAINLESS STEEL
9	ELASTIC STOP NUT	316 STAINLESS STEEL
10	GEAR REDUCER	CAST IRON
11	MOTOR - 1/4 HP	UNIT SUPPLIED W/O MOTOR
12	QUAD SEAL	BUNA
13	BACKWASH SHAFT	316 STAINLESS STEEL
14	O-RING	BUNA-N
15	STUD	STEEL SA 193 GR.B7
16	HEX NUT	STEEL SA 194 GR.2H
17	PILOT BUSHING HOUSING	DUCTILE IRON SA 395
18	O-RING	BUNA-N
19	PILOT BUSHING	DELFIN
20	BACKWASH ARM GUIDE	DUCTILE IRON
21	WASHER	STEEL

NOTES:

1. ALL FLANGE CONNECTIONS CONFORM TO BS4504 PN16.
2. FOR REPLACEMENT PARTS, MODEL NO., SIZE, AND SERIAL NO., FROM THE STRAINER NAMEPLATE MUST BE FURNISHED.
3. MAX. WORKING PRESSURE: 150 PSI @ 150° F (10.3 BAR @ 65.5° C)
4. WEIGHT: DRY-1840 LBS. (836 KGS.)
WET-2615 LBS. (1188 KGS.)
COVER WEIGHT: 705 (320 KGS.)
5. PART NO.: 25961000709
6. EXTERNAL COATING: ENG'G SPEC. ES-301

SECTION "A-A"

2" BSPT / 2" PN16 FF FLANGE
BACKWASH CONNECTION

2" BSPT DRAIN

1" BSPT DRAIN

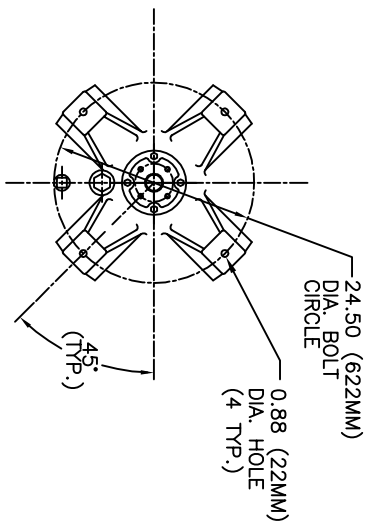

VIEW "B-B"
MOUNTING ARRANGEMENT

STRAINING ELEMENT:

CERTIFIED FOR:
P.O. NO.:
S.O. NO.:
NO. OF UNITS:
TAG NOS.:



EATON FILTRATION, LLC

900 FAIRMOUNT AVENUE, ELIZABETH, NEW JERSEY 07207

NAME: SIZE 250 MM (10") MODEL 2596
SELF-CLEANING STRAINER - DUCTILE IRON
BS4504 PN16 FF FLANGES

DRAWN	VAA	DATE	5/23/97	CERT.	VH	DATE	5/23/97	REV	C
SIZE	DWG	NO	A						

SD259630

ELECTRONIC FILE NAME: SD259630.DWG
REF. ECR D507 DATE 11/1/05

UNAUTHORIZED USE, MANUFACTURE OR REPRODUCTION IN WHOLE OR IN PART IS PROHIBITED. DRAWING, DESIGN AND OTHER DISCLOSURES PROPERTY OF EATON FILTRATION, LLC