

DCF-3000

The dual cleaning disc and twin actuator design of the DCF-3000 mechanically cleaned filter can be fabricated in a variety of materials and options. It can be used in many different applications and operating temperatures up to 400 °F (200 °C). It is ideal for highly viscous or sticky liquids with flow rates of up to 500 GPM (110 m³/h). For water-like liquids, it can handle flow rates up to 1,500 GPM (340 m³/h).



Two actuators isolate the actuation mechanism from the filtrate with a bridged system. The benefit is a long operating life for high pressure, high temperature conditions.

FEATURES

- No need for disposable filter media reduces operating, material and disposal costs
- Minimum product loss through highly concentrated discharge of contaminants
- Virtually maintenance- and interruption-free operation
- Safe operation through reduction or elimination of operator intervention
- Compact and cost-effective design to fit most installations
- Slotted wedge wire elements in stainless steel from 15 µm and perforated filter elements up to 1/4" (6.35 mm) handle a wide range of filtration requirements
- Available with POM (Delrin®) or PEEK cleaning discs
- Optional with Eaton control unit
- ASME U stamp available

TYPICAL APPLICATIONS

- Paper coatings • PCC/GCC slurries • Phenolic resins
- Detergents • Petroleum based greases • Ethanol processing
- Hot fry oils • CIP fluids (sodium hydroxide) • Starch
- Lime slurries • Adhesives • Curtain coaters • Nutraceuticals
- Machining coolants • Paint • Ink • Chocolate • Edible oils
- Tallow

When filtering high viscosity liquids for demanding applications, the DCF-3000 filter's twin actuator, dual disc models deliver tremendous benefits. It is available in flow rates up to 1,500 GPM (340 m³/h) with retentions of 15 µm to 1/4" (6.35 mm).

The DCF-3000 filter is equipped with the proven twin actuator and mechanical cleaning similar to the DCF-1600 filter. It is designed for higher flow rates and compatible with a wide range of fluid process conditions. A maximum operating pressure of 150 PSI (10 bar) along with a maximum temperature of up to 400 °F (200 °C) allows for multiple seals and cleaning disc material options.



Dual circular cleaning disc design ensures intimate contact with the screen to thoroughly and uniformly clean the media.



Powering Business Worldwide

DCF-3000 Disc Cleaning Filters

DCF-3000 Specifications

Approx. weight	639 lbs (290 kg)
Service height:	136 in (3,454 mm)
Flow rates at 100 µm:	Up to 1,100 GPM (250 m³/h)
Operating pressure:	30 - 150 PSI (2 - 10 bar)
Operating temperature, max.:	400 °F (200 °C)
Viscosity:	Water-like to 500,000+ cP
Standard retention:	15 - 1,100 µm
Housing material:	316 Stainless steel
Elastomers:	EPT/EPDM, FPM (Viton®), White Nitrile (food grade)
Cleaning discs:	POM (Delrin), PEEK
Packing:	Urethane, Teflon®, Viton and Gylon®/Viton
Process connections:	4 - 8 in 150# ANSI flanged
Purge connection:	2 in NPT/2 in BSPT
Air for actuator drive (clean, dry, non lubricated air):	80 PSI (5.5 bar) min. - 116 PSI (8 bar) max. 5.0 cfm (141.5 l/min)
Electrical for controllers:	115 VAC or 230 VAC, 50/60 Hz
Semi-auto voltage:	24 VDC, 115 VAC, 230 VAC
Flooded weight:	1,049 lbs (476 kg)

DCF-3000 Flow Rate

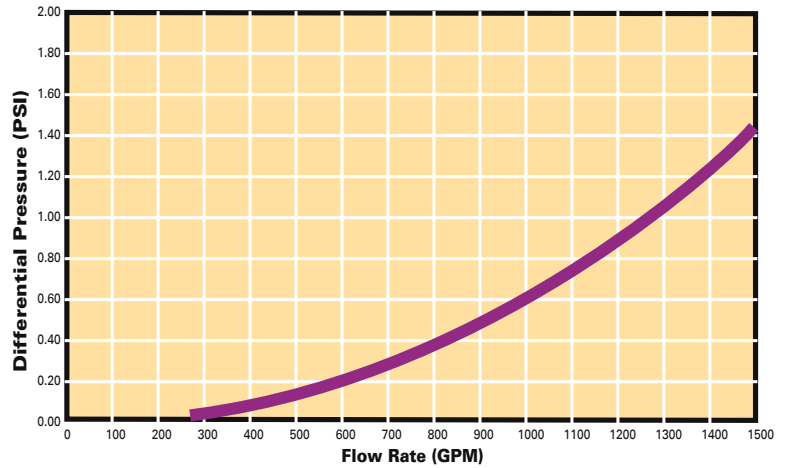

Slotted Wedge Wire Strainer Element Options

Inch	Micron	Mesh	% Open Area
.002	50	325	6
.003	75	200	9
.004	100	150	12
.006	150	100	17
.007	180	80	19
.008	200	70	21
.009	230	60	23
.015	380	40	33
.024	600	30	44
.030	700	20	50
.045	1140	15	60

Additional retentions available, consult Eaton.

Delrin®, Viton® and Teflon® are a registered trademarks of E. I. du Pont de Nemours and company.

Gylon® is a registered trademark of Garlock Sealing Technologies LLC.

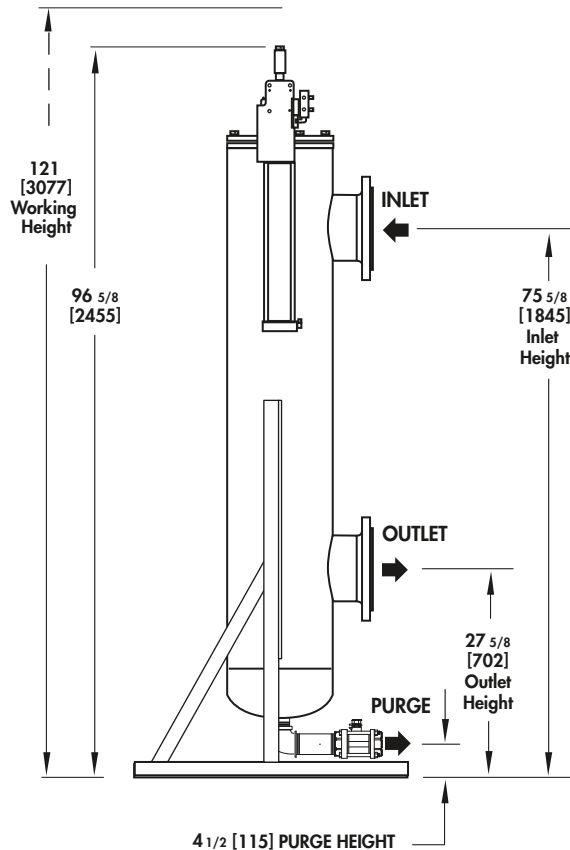

North America
44 Apple Street
Tinton Falls, NJ 07724
Toll Free: 800 656-3344
(North America only)
Tel: +1 732 212-4700

China
No. 3, Lane 280,
Linhong Road
Changning District, 200335
Shanghai, P.R. China
Tel: +86 21 5200-0099

Europe/Africa/Middle East
Auf der Heide 2
53947 Nettersheim, Germany
Tel: +49 2486 809-0

Singapore
100G Pasir Panjang Road #07-08
Singapore 118523
Tel: +65 6825-1668

Friedensstraße 41
68804 Altlußheim, Germany
Tel: +49 6205 2094-0

Brazil
Av. Ermano Marchetti, 1435 -
Água Branca, São Paulo - SP,
05038-001, Brazil
Tel: +55 11 3616-8461

An den Nahewiesen 24
55450 Langenlonsheim, Germany
Tel: +49 6704 204-0

For more information, please
email us at filtration@eaton.com
or visit www.eaton.com/filtration

US
12-2020

© 2020 Eaton. All rights reserved. All trademarks and registered trademarks are the property of their respective owners. All information and recommendations appearing in this brochure concerning the use of products described herein are based on tests believed to be reliable. However, it is the user's responsibility to determine the suitability for his own use of such products. Since the actual use by others is beyond our control, no guarantee, expressed or implied, is made by Eaton as to the effects of such use or the results to be obtained. Eaton assumes no liability arising out of the use by others of such products. Nor is the information herein to be construed as absolutely complete, since additional information may be necessary or desirable when particular or exceptional conditions or circumstances exist or because of applicable laws or government regulations.