

DCF-2000

Eaton's DCF-2000 is designed specifically to address the challenges associated with filtering coatings and slurries in the paper making industry. Eliminate paper breaks and streaks, reduce the environmental impact, and maximise uptime and productivity – for high production volumes and consistent product quality.



DCF-2000
single
configuration

DCF-2000

With a rugged motorised cleaning action, the DCF-2000 can handle the continuous processing requirements of protecting critical wet-end coating operations.

FEATURES

- Filters coatings with 48% to 72% dry solid content, at 75 microns and above – the tightest in the industry
- Continuously removes contaminants from the coating and efficiently purges collected contaminants while operating at a low, constant differential pressure
- Designed for continuous automatic operation – without the need for operator intervention
- Mechanical cleaning eliminates replacement media cost and reduces the expense of waste disposal
- Increased profitability – improves system efficiency, reduces paper breaks and the associated downtime
- Multiplex configurations available and connected to a common tapered header for high-flow applications

TYPICAL APPLICATIONS

- Paper coatings



DCF-2000
multiplex
configuration



Powering Business Worldwide

DCF-2000 Disc-Cleaning Filters

Driven at a constant rate and pressure, the cleaning disc continuously wipes collected debris from the screen. Collected contaminants are agitated in the collection chamber, keeping them in a semi-liquid state, ready to be purged from the system.

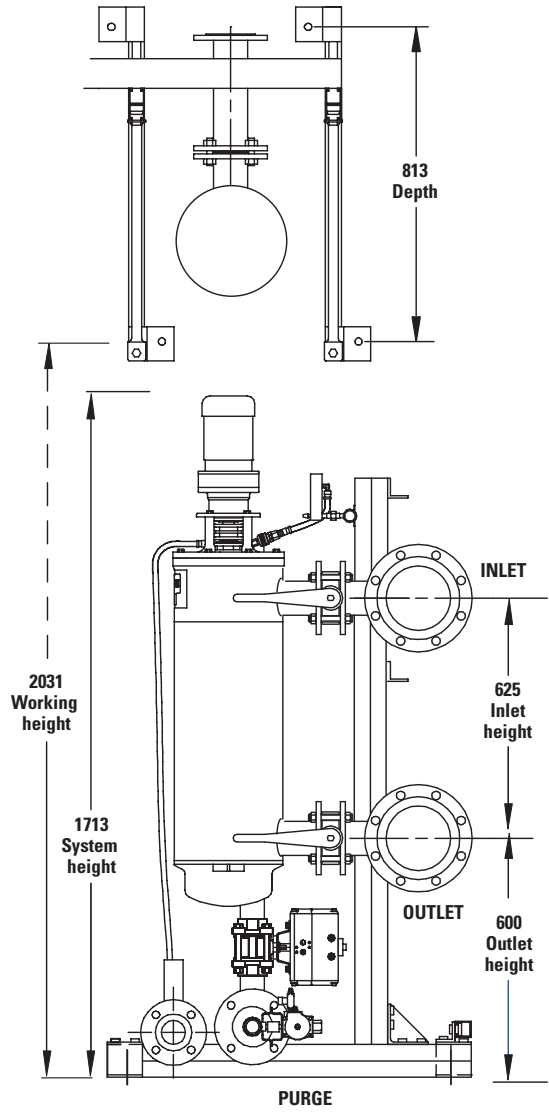
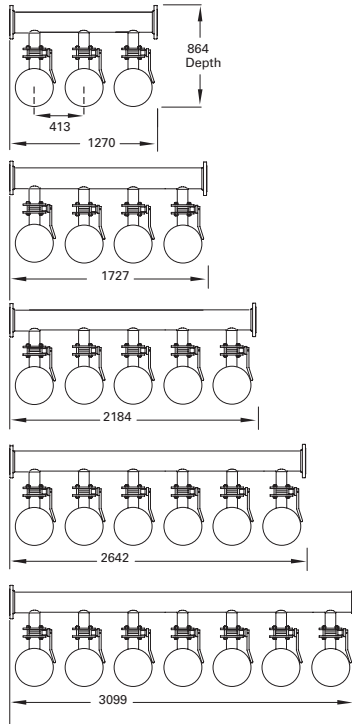
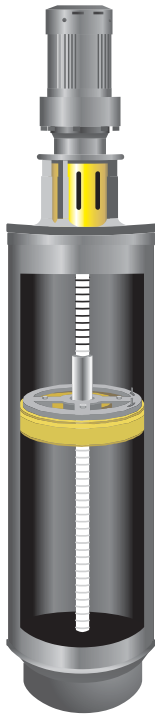

DCF-2000: SPECIFICATIONS

Single unit weight	256 kg
Service height	2031 mm
Total volumetric capacity	41.6 litres
Purge chamber capacity	6 litres
Filtration surface area	3935 cm ²
Flow rate range at 100 µm	6.8 – 45.4 m ³ /h
Temperature, maximum*	71 °C
Pressure, maximum	10 bar standard
Electrical for motor drive	Single phase 110/220 V, 50/60 Hz for control and three phase, 220/380/440/575 V (please specify), 50/60 Hz for motor.
Electrical for controllers	Single phase 110/220 V, 50/60 Hz

* Dependent on elastomer seal and cleaning disc material selection.

North America
44 Apple Street
Tinton Falls, NJ 07724
Toll Free: 800 656-3344
(North America only)
Tel: +1 732 212-4700

China
No. 3, Lane 280,
Linhong Road
Changning District, 200335
Shanghai, P.R. China
Tel: +86 21 5200-0099

Europe/Africa/Middle East
Auf der Heide 2
53947 Nettersheim, Germany
Tel: +49 2486 809-0

Singapore
100G Pasir Panjang Road #07-08
Singapore 118523
Tel: +65 6825-1668

Friedensstraße 41
68804 Altlußheim, Germany
Tel: +49 6205 2094-0
An den Nahewiesen 24
55450 Langenlonsheim, Germany
Tel: +49 6704 204-0

Brazil
Rua Clark, 2061 - Macuco
13279-400 - Valinhos, Brazil
Tel: +55 11 3616-8400



Powering Business Worldwide

For more information, please email us at filtration@eaton.com or visit www.eaton.com/filtration

© 2018 Eaton. All rights reserved. All trademarks and registered trademarks are the property of their respective owners. All information and recommendations appearing in this brochure concerning the use of products described herein are based on tests believed to be reliable. However, it is the user's responsibility to determine the suitability for his own use of such products. Since the actual use by others is beyond our control, no guarantee, expressed or implied, is made by Eaton as to the effects of such use or the results to be obtained. Eaton assumes no liability arising out of the use by others of such products. Nor is the information herein to be construed as absolutely complete, since additional information may be necessary or desirable when particular or exceptional conditions or circumstances exist or because of applicable laws or government regulations.

EN
08-2018

