



GUB Series Instrument Housings

Installation & Maintenance Information

IF 1112

SAVE THESE INSTRUCTIONS FOR FUTURE REFERENCE

APPLICATION

GUB Series Instrument Housings are used to enclose ammeters, voltmeters, wattmeters, varmeters, power-factor meters, tachometer indicators, pressure controls, temperature controls, etc. in a threaded rigid metallic conduit system. The GUB 1103, 11031, 2184, 3190, 3191, 6191, 6192, and 6193 Series are specifically designed to enclose 3-1/2", 4", 4-1/2" or 6" round or rectangular instruments such as ammeters and voltmeters.

GUB Series Instrument Housings are UL Listed for use in Class I, Group D; Class II, Groups E, F and G, and Class III hazardous (classified) locations as defined by the National Electrical Code®.

All GUB Instrument Housings have threaded covers with glass windows for viewing the scale, dial or setting of the enclosed instrument. The GUB 1103, 11031, 2184, 3190, 3191, 6191, 6192, and 6193 enclosures are provided with universal mounting plates and posts in the bodies to support the instrument close to the glass window.

INSTALLATION

⚠ WARNING

Electrical power must be "OFF" before and during installation and maintenance.

1. For the GUB Instrument Housings the desired location for conduit entry must be selected before the enclosure is mounted. The body can be rotated to allow conduit entry at the sides or bottom.
2. Select a mounting location that will provide sufficient strength and rigidity to support the enclosure as well as the control devices and wiring.
3. Securely fasten the enclosure to the mounting location. The enclosures are provided with cast external mounting lugs with bolt clearance holes and spacings as noted in Fig. 1 & 2.

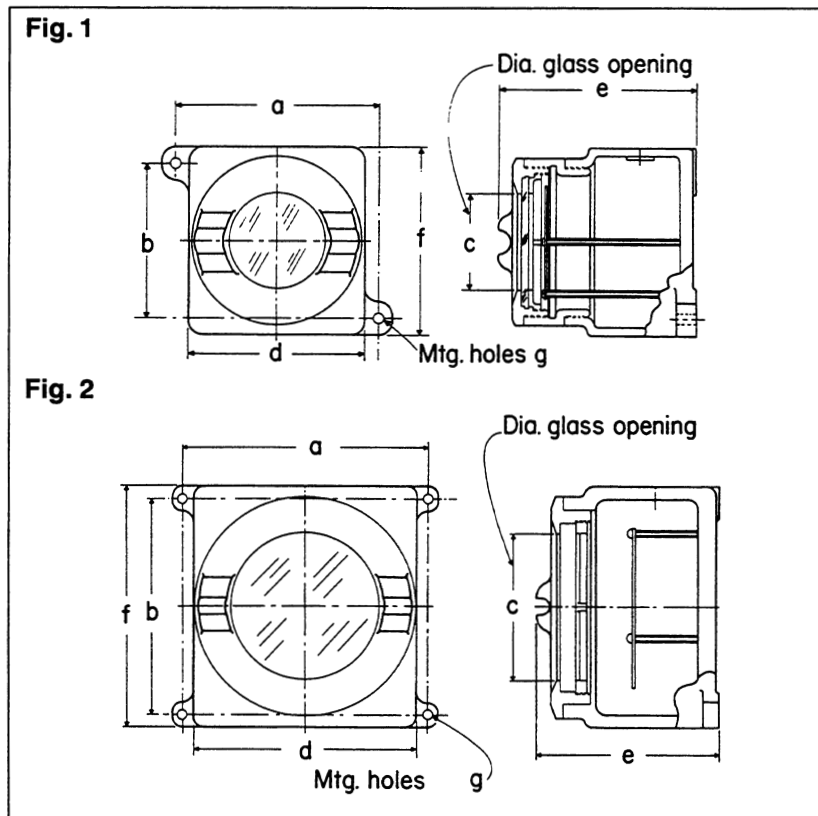

Cat. #	Fig. #	a	b	c	d	e	f	g
GUB1103-1-20	1	7½	5¼	3⅞	6½	5⅜	7	1⅜
GUB11031-1-20	1	7½	5¼	3⅞	6½	7⅞	7	1⅜
GUB6191-1-20	1	9½	8¾	5¼	8½	8½	10	7⅞
GUB6192-1-20	1	9½	8¾	5¼	8½	10	10	7⅞
GUB6193-1-20	1	9½	8-34	5¼	8½	11½	10	7⅞
GUB2184-1-20	1	9	8¾	5¼	8	6	10	1⅜
GUB3190-1-20	2	12⅞	10¾	7⅞	11	8⅞	12	7⅞
GUB3191-1-20	2	12⅞	10¾	7⅞	11	10⅞	12	7⅞

⚠ CAUTION

- The hazardous location information specifying class and group listing of each instrument housing is marked on the nameplate on each enclosure.
- No conduit openings are to be added in the field.
- All unused conduit openings must be plugged. Seal unused openings with Crouse-Hinds PLG threaded pipe plugs. Plugs must be a minimum of 1/8 inch thick and engage a minimum of five full threads.

4. Install Crouse-Hinds EYS sealing fittings when required by Section 501-5 and/or 502-5 of the National Electrical Code® plus any other applicable codes.
5. Unthread instrument housing cover and carefully set it aside to prevent damage to the cover threads and glass window to metal joint.
6. Pull wires into enclosure, making certain they are long enough to make the required connections and to remove the instrument if servicing is required. Install instrument and make all electrical connections.
7. Test wiring for correctness by checking continuity and also check for unwanted grounds with insulation resistance tester. Make sure test equipment being used will not damage instrument to be housed in the GUB Instrument Housing enclosure.
8. Carefully rethread cover into enclosure housing. Tighten cover until cover flange contacts body face. See CAUTION below.

⚠ CAUTION

Use care to prevent dirt, grit or other foreign material from lodging on threads. If any such material settles on these threads, clean them with kerosene or Stoddard solvent*, then relubricate with Crouse-Hinds Type STL thread lubricant.

(*To avoid the possibilities of an explosion, oxidation and corrosion, do not use gasoline or similar solvents.)

MAINTENANCE

⚠ WARNING

Always disconnect primary power source before opening enclosure for inspection of service.

1. Frequent inspection should be made. A schedule for maintenance check should be determined by the environment and frequency of use. It is recommended that it should be at least once a year.
2. Perform visual, electrical and mechanical checks on all components on a regular basis.
 - Visually check for undue heating evidenced by discoloration of wires or other components, damaged parts, or leakage evidenced by water or corrosion in the interior.
 - Electrically check to make sure that all connections are clean and tight.
 - Mechanically check that all parts are properly assembled.

All statements, technical information and recommendations contained herein are based on information and tests we believe to be reliable. The accuracy or completeness thereof are not guaranteed. In accordance with Crouse-Hinds "Terms and Conditions of Sale", and since conditions of use are outside our control, the purchaser should determine the suitability of the product for his intended use and assumes all risk and liability whatsoever in connection therewith.
