

Green Motion Home Installation manual



DISCLAIMER OF WARRANTIES AND LIMITATION OF LIABILITY

The information, recommendations, descriptions and safety notations in this document are based on Eaton's experience and judgment and may not cover all contingencies. If further information is required, an Eaton sales office should be consulted. Sale of the product shown in this literature is subject to the terms and conditions outlined in appropriate Eaton selling policies or other contractual agreement between Eaton and the purchaser.

THERE ARE NO UNDERSTANDINGS, AGREEMENTS, WARRANTIES, EXPRESSED OR IMPLIED, INCLUDING WARRANTIES OF FITNESS FOR A PARTICULAR PURPOSE OR MERCHANTABILITY, OTHER THAN THOSE SPECIFICALLY SET OUT IN ANY EXISTING CONTRACT BETWEEN THE PARTIES. ANY SUCH CONTRACT STATES THE ENTIRE OBLIGATION OF EATON. THE CONTENTS OF THIS DOCUMENT SHALL NOT BECOME PART OF OR MODIFY ANY CONTRACT BETWEEN THE PARTIES.

In no event will Eaton be responsible to the purchaser or user in contract, in tort (including negligence), strict liability or other-wise for any special, indirect, incidental or consequential damage or loss whatsoever, including but not limited to damage or loss of use of equipment, plant or power system, cost of capital, loss of power, additional expenses in the use of existing power facilities, or claims against the purchaser or user by its customers resulting from the use of the information, recommendations and descriptions contained herein. The information contained in this manual is subject to change without notice.

Content overview

1	INTRODUCTION	1
1.1	Field of applications	2
1.2	Symbols used in this manual	2
1.3	Conventions used in this document	3
2	CAUTIONS	4
2.1	Operating environment and restrictions	4
2.2	Suggested protections during the installation	5
2.3	Protection from electric shock	5
2.4	Electromagnetic fields and interferences	6
2.5	Warning decals and rating plate	6
2.6	Residual risks	6
3	GENERAL DESCRIPTION	7
3.1	Front and back views	7
3.2	Right and left views	9
3.3	Bottom view	10
3.4	Types of connectors	10
4	RELEVANT INFORMATION PRIOR TO THE INSTALLATION	11
4.1	Tools required for the installation	11
4.2	Checking the box contents	11
4.3	Dimensions and weight	11
4.4	Lifting, transportation and unloading instructions	12
4.5	Unpacking	12
5	MOUNTING AND INSTALLATION	13
5.1	Positioning the Green Motion Home EV charger	13
5.2	How to open/close the housing of the Green Motion Home EV charger	13
5.3	Mounting	14
6	ELECTRICAL CONNECTIONS	17
6.1	Caution	17
6.2	Standard wiring	17
6.3	Electrical connection and terminals	19
6.4	Charging current limitation	21
6.5	Installation of an external switching device	24
7	COMMISSIONING	31
7.1	Green Motion Home switch-on	31
7.2	LED indicator	32
7.3	Eaton Green Motion Charger controller application	33
7.4	Removing the plug	33

8 MAINTENANCE34
8.1 Factory reset 34
8.2 Uninstall 36
8.3 EV charger updates 36
8.4 Disposal 36

9 TROUBLESHOOTING37

10 TECHNICAL DATA38
10.1 Rating plate 38
10.2 Technical datasheet 39

11 WARRANTY AND TECHNICAL SUPPORT39

1. Introduction

Thank you for choosing the Eaton Green Motion Home EV charger.

Before you start

This manual contains important instructions that must be followed during the installation, operation and maintenance of the Eaton Green Motion Home electric vehicle charger. All instructions must be read before installing and operating the equipment. This manual should be retained for future reference.

Please note that the Green Motion Home EV charger must only be installed and maintained by professional and qualified personnel, i.e. an Eaton technical support representative or professional installer. Professional and qualified personnel must be expert in the field and must therefore be responsible for commissioning the system in accordance with the manufacturer's instructions and ensure that all steps of the installation, operation and maintenance comply with local legislation.

There are no user-serviceable parts inside the equipment. Failure to observe the above will void the provided warranty and Eaton cannot be held legally accountable.

The contents of this manual are the copyright of Eaton and may not be copied, reproduced or redistributed in whole or in part without Eaton's prior written permission. While every care has been taken to ensure the accuracy of the information contained in this manual, Eaton assumes no liability for any error or omission. Eaton reserves the right to modify the designs of its products. The unauthorized copying and lending of this manual is prohibited.

Technical disclaimer

All drawings, descriptions or illustrations contained in this document serve to provide a clear overview and/or technical explanation of the present product and its various components and accessories. In line with our goal to continuously improve the products and the customer service we provide, all specifications contained in this document are subject to change without notice, as Eaton reserves the right to modify the designs of its products.

Legal entity

Eaton Industries Manufacturing GmbH

Address: Place de la Gare 2
1345 Le Lieu
SWITZERLAND

Web: www.eaton.com

1.1 Field of applications

This installation manual is intended for professional and qualified personnel. It describes how to securely install and commission the Eaton Green Motion Home AC EV charger.

Table 1. Overview of the Eaton Green Motion Home EV charger

Power input		AC EV charger	
Input voltage		1 x 230 V (50 Hz) – 1 phase	3 x 400 V (50 Hz) – 3 phase
Input current		1 x 16 A (3.7 kW) – 1 phase	1 x 32 A (7.4 kW) – 1 phase 3 x 16 A (11 kW) – 3 phase 3 x 32 A (22 kW) – 3 phase
Power output			
Output power		3.7 kW to 22 kW	
Output type		Type 2 cable or Socket (T2 or T2S)	
Type of cables		Straight	
Simultaneous charging		1	
Environmental			
Operating temperature		-25 °C to +45 °C	
Altitude		Up to 2000 m	
Installation		Wall-mounted; indoor or outdoor	
Humidity		< 95 % relative humidity	
Mechanical			
Mounting method		Wall-mounted Floor-mounted column (Optional)	
Dimensions (W x H x D) in mm		285.5 x 264 x 116	
Weight (without cables)		3 kg	
Cable length		5 meters	
Standards			
Conformity		IEC 61851-1	
Degree of protection		IP54	
Earth leakage detection		Built-in 6 mA DC protection	
Impact strength		IK08	

1.2 Symbols used in this manual

1.2.1 Related icons



Imminent dangers causing serious injuries. Danger of death.



Hazardous behaviors that could cause serious injuries.
Hazardous behaviors that could cause death.



Behaviors that could cause minor injuries to people or minor damages to property.



An electric shock can be fatal.
Avoid touching internal or external parts normally live while the system is powered on.



Read the instructions. These instructions are intended for professional and qualified personnel.
Professional and qualified personnel must be expert in the field and must therefore be responsible for commissioning the system in accordance with the manufacturer's instructions and local legislation.



The notes preceded by this symbol relate to technical issues and ease of operations.



The EU Directive on Waste Electrical and Electronic Equipment (WEEE).

1.3 Conventions used in this document

This manual adopts the following type conventions and acronyms to refer to the Eaton Green Motion Home EV charger or its parts:

ALL CAPITALS highlight critical points that require careful attention.

All abbreviations used in this document are listed in Table 2.

Table 2. Glossary

Abbreviation	Description
AC	Alternating current
CU	Control unit
DC	Direct current
DHCP	Dynamic Host Configuration Protocol
EMC	Electromagnetic compatibility
EMI	Electromagnetic interference
EV	Electric vehicle
FW	Firmware
GND	Ground
HW	Hardware
IEC	International Electrotechnical Commission
IP	Internet Protocol
LAN	Local area network
LCD	Liquid crystal display
LED	Light-emitting diode
N	Neutral
NAT	Network address translation
OV	Over-voltage
PAT	Port Address Translation
PCB	Printed Circuit Board
PE	Protective earth
PPE	Personal protective equipment
RCD	Residual current device
RCMU	Residual current monitoring unit
SIM card	Subscriber identity module card
SW	Software
TCP	Transmission Control Protocol
UI	User interface
WEEE	Waste of Electrical and Electronic Equipment

2. Cautions

These instructions are intended for professional and qualified personnel.

Before carrying out any operations, ensure you have read and understood this manual. Do not make changes and do not carry out maintenance operations not described in this manual. The manufacturer does not accept responsibility for injuries to people and property damages that occur because the information within this manual has not been read and followed.

The customer is civilly liable for the qualification and mental or physical state of the professional and qualified personnel who operate this equipment. They must always use the personal protective equipment required by the laws of the country of destination and anything else provided by their employer.



It is strictly prohibited to open the unit except as described in this manual. The installation of the equipment must be carried out by professional and qualified personnel. They must not be under the influence of alcohol or drugs or have prosthetic heart valves or pacemakers.



For any doubts or problems regarding the use of the system, even if not described here, please contact your Eaton sales representative.

The unit must not be subjected to any type of modification. Eaton declines any responsibility if the rules for correct installation are not respected and is not responsible for the system upstream or downstream of the equipment it supplies.

The exclusion of protective devices is extremely dangerous and relieves the manufacturer of any responsibility for damage to people and property.

A first aid kit must be provided.

2.1 Operating environment and restrictions

Each system must be used exclusively for the operations it was designed for and within the operative ranges specified in the rating plate and/or in the relative technical datasheet, in accordance with the national and international safety standards.

Any use different from the intended use specified by the manufacturer is to be considered totally inappropriate and dangerous, and in this case the manufacturer declines all responsibility.

Please check the regulations applied by the electricity provider.

The unit can be connected to the distribution network in accordance with local rules.

The unit should comply with all the technical specifications.



Improper or unauthorized use:

Although carefully constructed, all electrical appliances can catch fire.

The unit is intended for indoor or outdoor installation.

Optimal operation of the unit is in the temperature range -25 °C to +45 °C.

The unit must be transported and stored in indoor locations in the temperature range -25 °C to +45 °C.

The unit must be used in locations free from acids, gases or other corrosive substances.

The unit must be used and stored in locations with relative humidity below 95 %.

The unit must be transported in locations with relative humidity below 95 %.

The unit must be used below a maximum altitude of 2000 m above sea level.

2.2 Suggested protections during the installation

For obvious reasons, the manufacturer cannot envisage all potential types of installations and locations where the equipment might be installed; the customer must therefore clearly inform the manufacturer of specific conditions of installation. Eaton declines any responsibility if the unit is incorrectly installed.

The professional and qualified personnel must be correctly informed. The professional and qualified personnel must therefore read and follow the technical instructions contained in the manual and in the enclosed documentation.

The instructions provided in this manual do not replace the safety regulations of the installation and operational technical data printed on the products, nor do they replace the current safety standards enforced in the country where the equipment is installed, and the rules dictated by common sense.

The manufacturer can provide theoretical or practical training to professional and qualified personnel, either on its site or on the customer's premises, as specified at the time of drawing up the contract.

The equipment must not be used if any operational fault is identified.

Temporary repairs should be avoided; repair work must be carried out only with genuine spare parts, which must be installed in accordance with the intended use.

The responsibilities deriving from the commercial components are delegated to the respective manufacturers.

Avoid touching the equipment enclosure during the equipment operation.

The equipment enclosure could overheat during its operation.

As soon as it is switched off, the surface of the equipment could be hot, therefore great care must be taken. In the event of fire, CO₂ foam extinguishers must be used, and self-vacuum systems must be used to put out fires in enclosed spaces.

If the noise level exceeds legal limits, the working area must be restricted, and anyone who has access to the area must wear ear defenders or ear plugs.

The noise level produced by the equipment in normal working conditions is lower than 50 dB.

During the installation process, special attention must be paid to fixing the equipment and its components. At this stage, restricting or preventing access to the installation area is recommended.

Professional and qualified personnel are recommended to wear clothing and personal protective equipment (PPE) provided by their employer. Professional and qualified personnel must not wear clothes or accessories that could start fires or produce static electricity, or any item of clothing that could affect personal safety. When carrying out any operation on the equipment, clothes and instruments must be suitably insulated.

Professional and qualified personnel must NOT access the equipment with bare feet or wet hands.

Professional and qualified personnel must always ensure that nobody else is able to reset or operate the equipment during maintenance and must report any fault or deterioration caused by wear or by aging, in order to restore the correct safety conditions.

Professional and qualified personnel must always pay attention to the working environment to ensure it is well lit and has a suitable escape route.

A first aid kit must be provided.

2.3 Protection from electric shock



An electric shock can be fatal.
Avoid touching internal or external parts normally live while the system is powered on.



Cables and connections must always be secured, in good condition, insulated and suitably sized.

2.4 Electromagnetic fields and interferences

Electromagnetic fields may have harmful effects (unknown to date) on the health of people who are subjected to long exposure. Avoid standing less than 20 cm from the equipment for long periods of time.



Professional and qualified personnel must be expert in the field and are therefore responsible for commissioning the system in accordance with the manufacturer's instructions and local legislation. If electromagnetic interferences are detected, professional and qualified personnel should contact an Eaton technical support representative.



Connect the unit's external frame or other conductive parts to ground to ensure system protection and the highest level of safety for the operators.



National standards related to grounding must be complied with.

2.5 Warning decals and rating plate



The labels on the equipment must NOT be removed, damaged, soiled or hidden.

The labels must always be visible and in good condition.

The technical data shown in this manual does not replace those shown on the data plates on the equipment.

2.6 Residual risks



Despite the cautions and safety systems in place, some residual risks will still be present, which cannot be removed. These risks are listed in the following table, along with recommendations to prevent or mitigate them.

Table 3. Residual risks

Risk assessment	Recommended solution
Noise pollution caused by installations in unsuitable environments or where professionals work on a regular basis.	Reassess the installation environment or site.
Unsuitable ventilation in the location, causing equipment to overheat and the discomfort of people who are on the site.	Restore adequate ambient conditions and ventilate the site.
Protection from the elements such as water ingress, low temperatures, high humidity, etc.	Maintain adequate ambient conditions for the equipment.
Do not obstruct openings on the equipment.	Use suitable PPE or wait for the equipment to cool down before accessing it.
Dirt affects the system and prevents the safety labels from being read.	Adequately clean the equipment, the labels and the workplace.
Installation done poorly.	Request a training course.
During the installation stage, provisionally fixing the equipment or its components can be hazardous.	Take care and restrict access to the installation area.
Accidentally disconnecting the quick connectors while the equipment is operational or making incorrect connections can produce electric arcs.	Take care and restrict access to the installation area.

3. General description

The following images show different views of the Green Motion Home AC EV charger.

3.1 Front and back views

Figure 1. Front and back views of the Green Motion Home EV charger

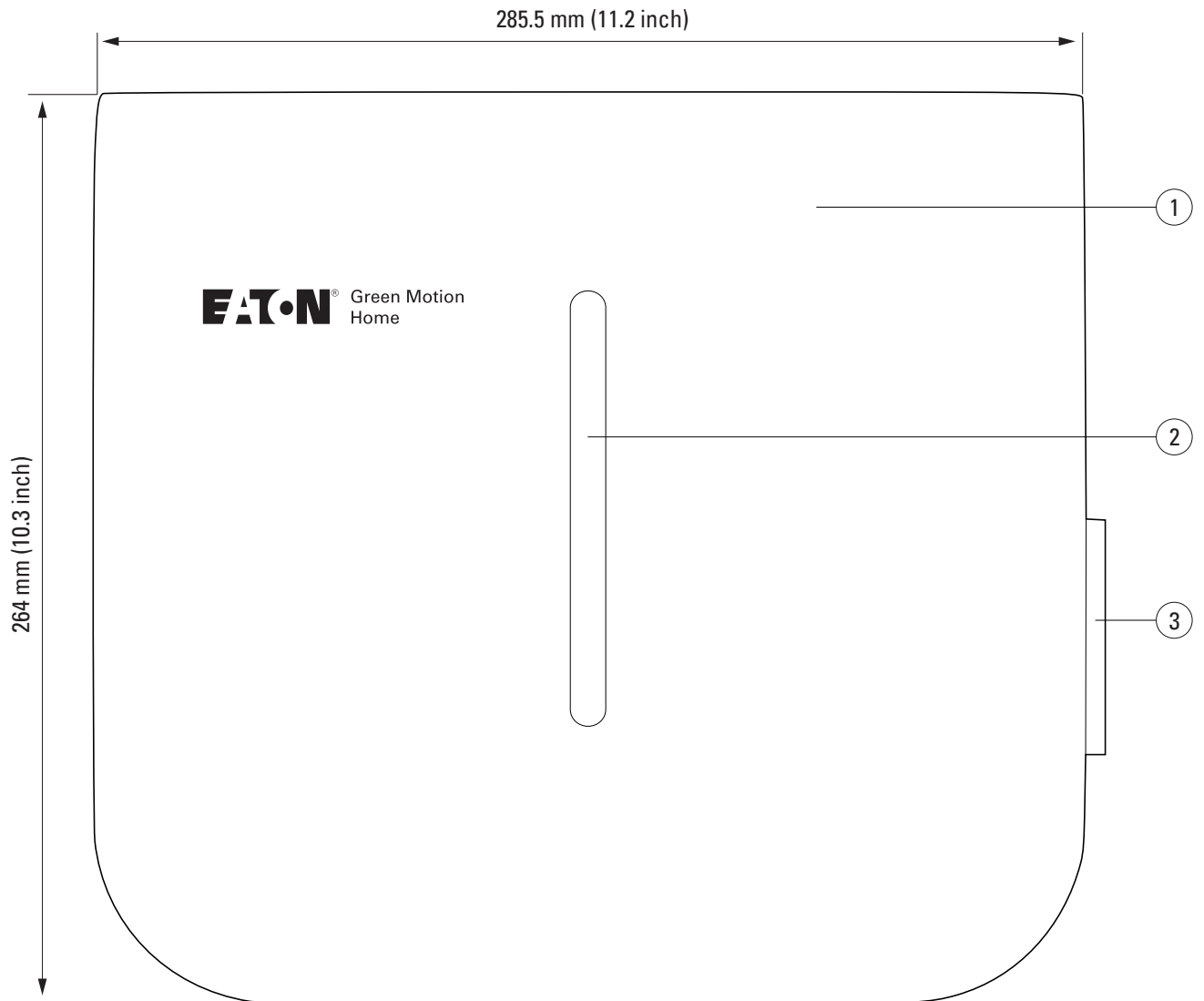

Tag	Description
①	Housing
②	Status indicator LED
③	Type 2 plug holder

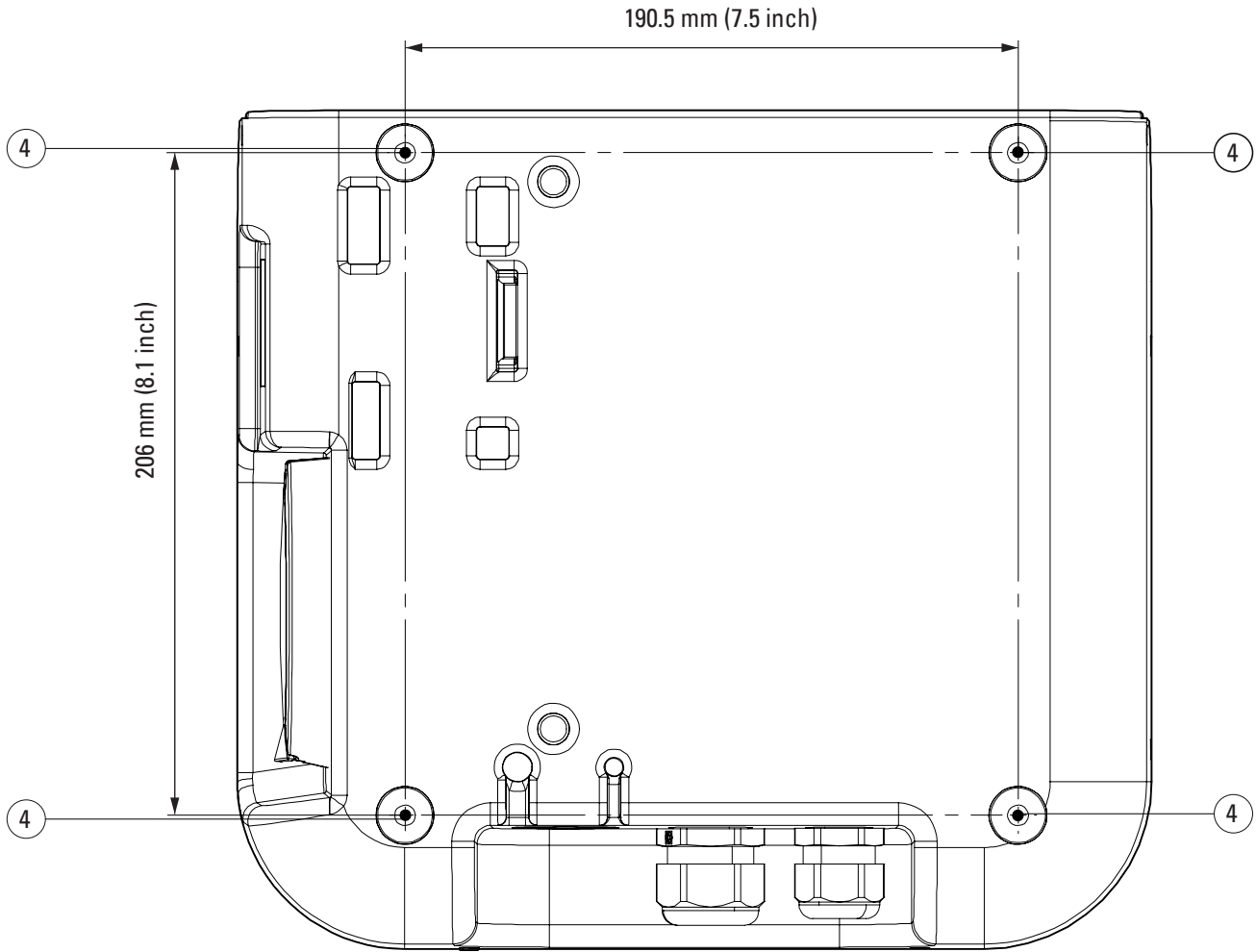

Tag	Description
④	Mounting holes

3.2 Right and left views

Figure 2. Right and left views of the Green Motion Home EV charger

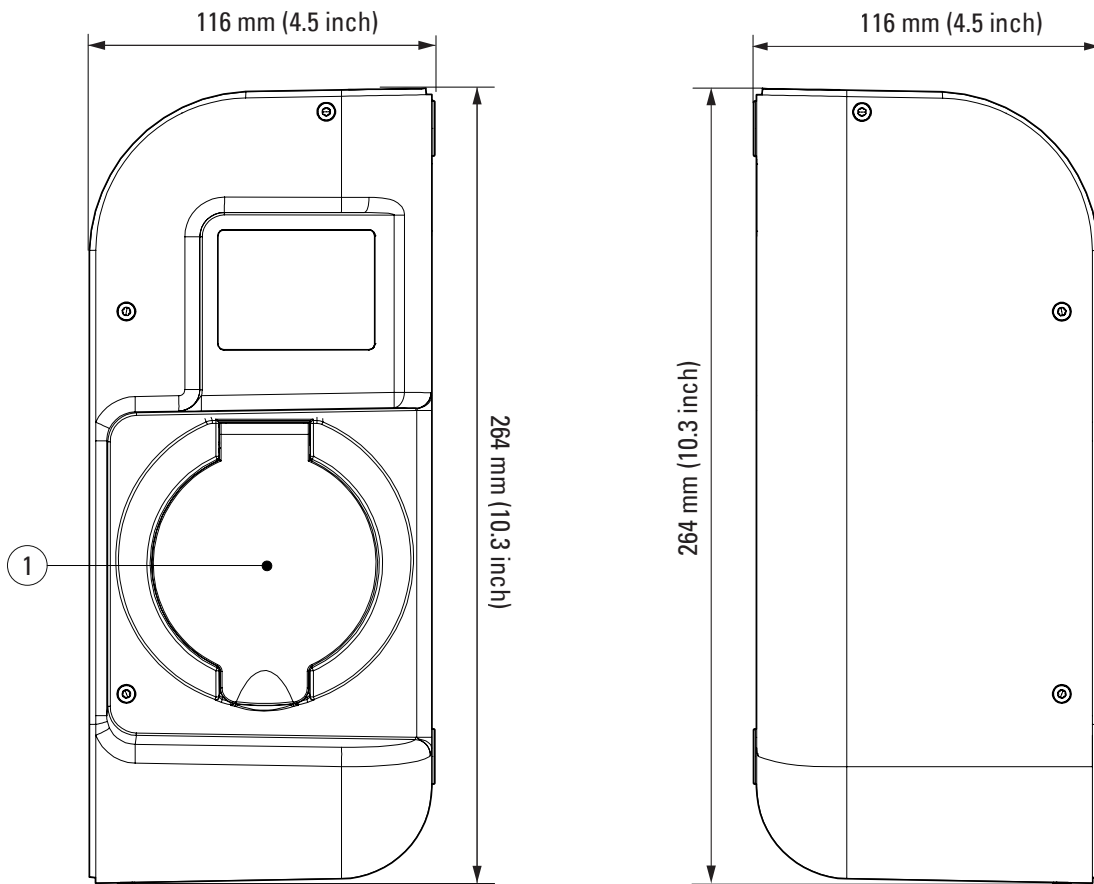

Tag	Description
①	Type 2 socket inlet

3.3 Bottom view

Figure 3. Bottom view of the Green Motion Home EV charger

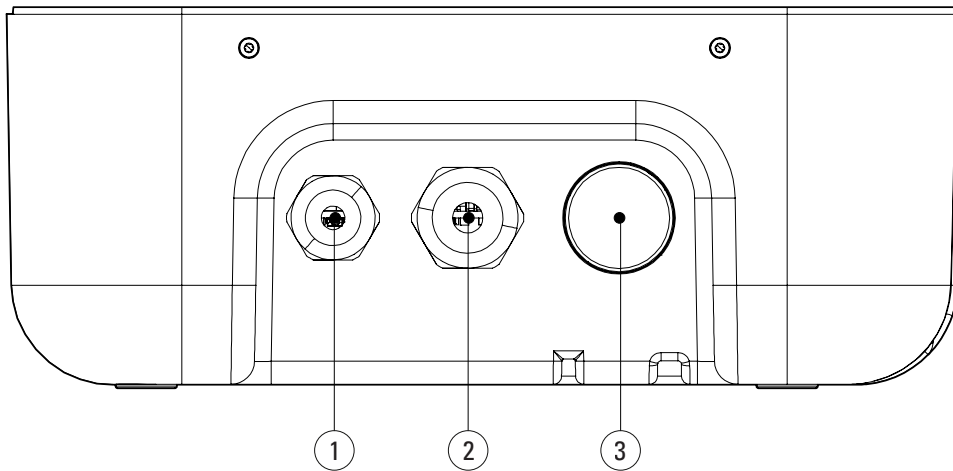

Tag	Description
①	Screw plug M20 (Communication)
②	Cable gland with locking nut M32 (Power input)
③	Cable gland with locking nut M32 (Cable output for the SKU version with the cable)

3.4 Types of connectors

The Green Motion Home EV charger can be provided with two types of connectors:

1. Type 2 connector with cable (Mode 3), 230 V/400 V 16 A/32 A for either single or three phases
2. Type 2 connector with socket (Mode 3), 230 V/400 V 16 A/32 A for either single or three phases.

The maximum power output a Type 2 connector can deliver, independently from the EV charger rated power, is 22 kW.

Figure 4. Illustration of connector Type 2

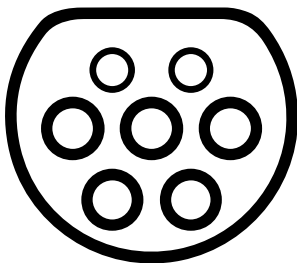

4. Relevant information prior to the installation



The installation must be carried out only by professional and qualified personnel.



Installation, commissioning, maintenance or retrofitting of the EV charger must be performed by professional and qualified personnel who are responsible for complying with existing standards and local installation regulations.



During the installation, ensure the equipment is powered off.

4.1 Tools required for the installation

To perform the installation, professional and qualified personnel should have the following tools:

- Spirit level
- Pencil
- Torx T-10 screwdriver
- Flat-head screwdriver
- Tongue-and-groove plier
- Drilling machine

4.2 Checking the box contents

The Green Motion Home EV charger box should contain the following parts:

- Green Motion Home EV charger
- Quick start guide
- Safety guidelines
- Drilling template
- Four adhesive gaskets
- Leaflet (white) containing factory hot spot details
- Leaflet (green) containing unique device identification code (UUID), required to pair the charger with mobile app
- Floor-mounted column (optional)
- Cable holder (optional)

4.3 Dimensions and weight

Table 4 shows the dimensions and weight of the Green Motion Home EV charger.

Table 4. Dimensions and weight of the Green Motion Home EV charger

EV charger	
Dimensions (W x H x D) in mm	285.5 x 264 x 116
Weight in kg with cables (max.)	8

4.4 Lifting, transportation and unloading instructions

Transportation and handling

Transportation of the equipment, especially on the road, must be carried out in such a way as to protect the system components (especially electronic components) from major impacts, humidity, vibrations, etc.

During handling, sudden or fast movements that could cause the system to sway dangerously must be avoided.

Lifting

Eaton packs and protects each component by using devices that ease its transportation and handling. These operations must be carried out by professional and qualified personnel specialized in loading and unloading components.

The ropes and vehicles used for lifting must be able to withstand the weight of the equipment.

Do not lift multiple units or parts of the equipment at the same time, unless otherwise advised.

The Green Motion Home EV charger is not equipped with specific lifting tools.



Do not underestimate the weight of the Green Motion Home EV charger; check the technical specifications.

Do not move or stop the hanging load above people or things.

Do not let it drop with too much force.

4.5 Unpacking



Remember that the packaging elements (cardboard, cellophane, staples, adhesive tape, straps, etc.) can cause cuts and/or injuries, if not handled with care. They must be removed with appropriate tools and must not be handled by non-responsible people (i.e. children).

The packaging components must be removed and disposed of in accordance with the local regulations and laws of the country of installation.

Check the integrity of the packaging before opening.

Open the packaging and remove the Green Motion Home EV charger carefully to avoid damaging the external casing or the internal electronic parts.

Before commissioning, ensure that the external casing of the Green Motion Home EV charger is in good condition and free from damage sustained during transportation.

5 Mounting and installation

5.1 Positioning the Green Motion Home EV charger

The installation position of the Green Motion Home EV charger must meet the following conditions:

- The EV charger must be installed in a place with relative humidity below 95 %.
- Optimal operation of the EV charger is in the temperature range -25 °C to +45 °C.
- Install the EV charger to ensure easy access to the controls and connections.
- The surface of the wall where the EV charger will be installed must be able to take its weight (max. 8 kg).
- The EV charger must be used below a maximum altitude of 2000 m above sea level.
- If the EV charger is targeted to be used by disabled people, refer to national requirements for charging station accessibility.
- If the user does not use a wheelchair, a height of 1500 mm from ground level is optimal.
- The power supply cable and the communication cable are introduced through the cable glands on the bottom of the EV charger.



Do not mount the EV charger above or under flammable building materials.
Do not install the EV charger in areas where highly flammable substances are present.
Do not install the EV charger in areas subject to explosion hazard.



To prevent the risk of electric shock or other injury, check that there are no electrical or hydraulic lines in the walls before drilling the mounting holes of the EV charger.



Make sure there is enough free space for air circulation around the EV charger. Local regulations may require larger clearances. It is also recommended that the Green Motion Home T2/T2S version of the charger be mounted with spacers when installed on the wall, to ensure free access to the charging socket.



Eaton is committed to minimizing the cybersecurity risk in its products and deploying cybersecurity best practices in its products and solutions, making them more secure, reliable and competitive for customers. For more information related to secure installation, please refer to product documentation at www.eaton.com

5.2 How to open/close the housing of the Green Motion Home EV charger



Before starting the connection operations, make sure that the charging cable is not connected to the vehicle, that the external AC-line main switch is turned off and that the circuit breakers are open.

Follow these steps to open the Green Motion Home EV charger housing.



When removing the front cover, be careful not to damage the cable connections.

Step 1. Unscrew the eight screws of the EV charger housing.

Figure 5. Location of the eight screws of the Green Motion Home EV charger housing

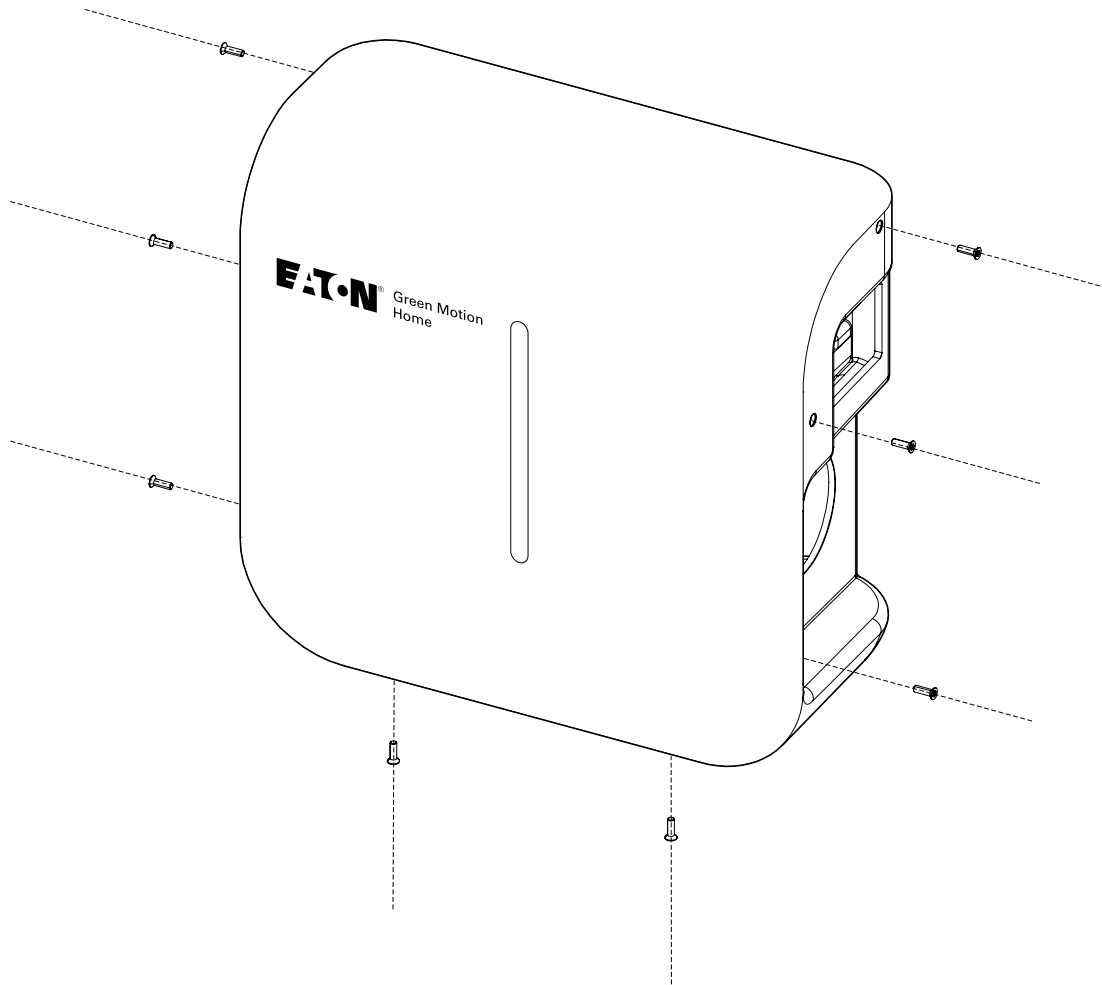

Step 2. Lift and carefully remove the front cover. Do not break any cables from the electrical board.

Step 3. Disconnect the connection cables from the front cover.

5.3 Mounting

The EV charger can be mounted directly onto the wall or on a floor-mounted column (optional).

Step 1. Use a spirit level to place the drilling template level on the wall. Make sure the template's top is at a height of 1500 mm from ground level, for optimal accessibility.¹

Step 2. Mark the holes with a pencil and remove the drilling template.

Step 3. Drill four holes in the wall as shown in Figure 6.

Step 4. Place four gaskets around the four slots on the outside of the unit, as shown in Figure 7.

Step 5. Fix the unit to the wall with four \varnothing 6-mm screws.



Please note that the appropriate type of plastic plugs and screws must be selected by a professional and qualified personnel, based on the following considerations:

- the installation location,
- the type of the wall on which the EV charger is to be mounted.

This is to ensure the safest possible mounting of the Green Motion Home EV charger.

The power supply cable is introduced through the cable gland on the bottom of the EV charger.

¹ Refer to national requirements to make the EV charger accessible to disabled people.

Figure 6. The Green Motion Home EV charger drilling template on wall

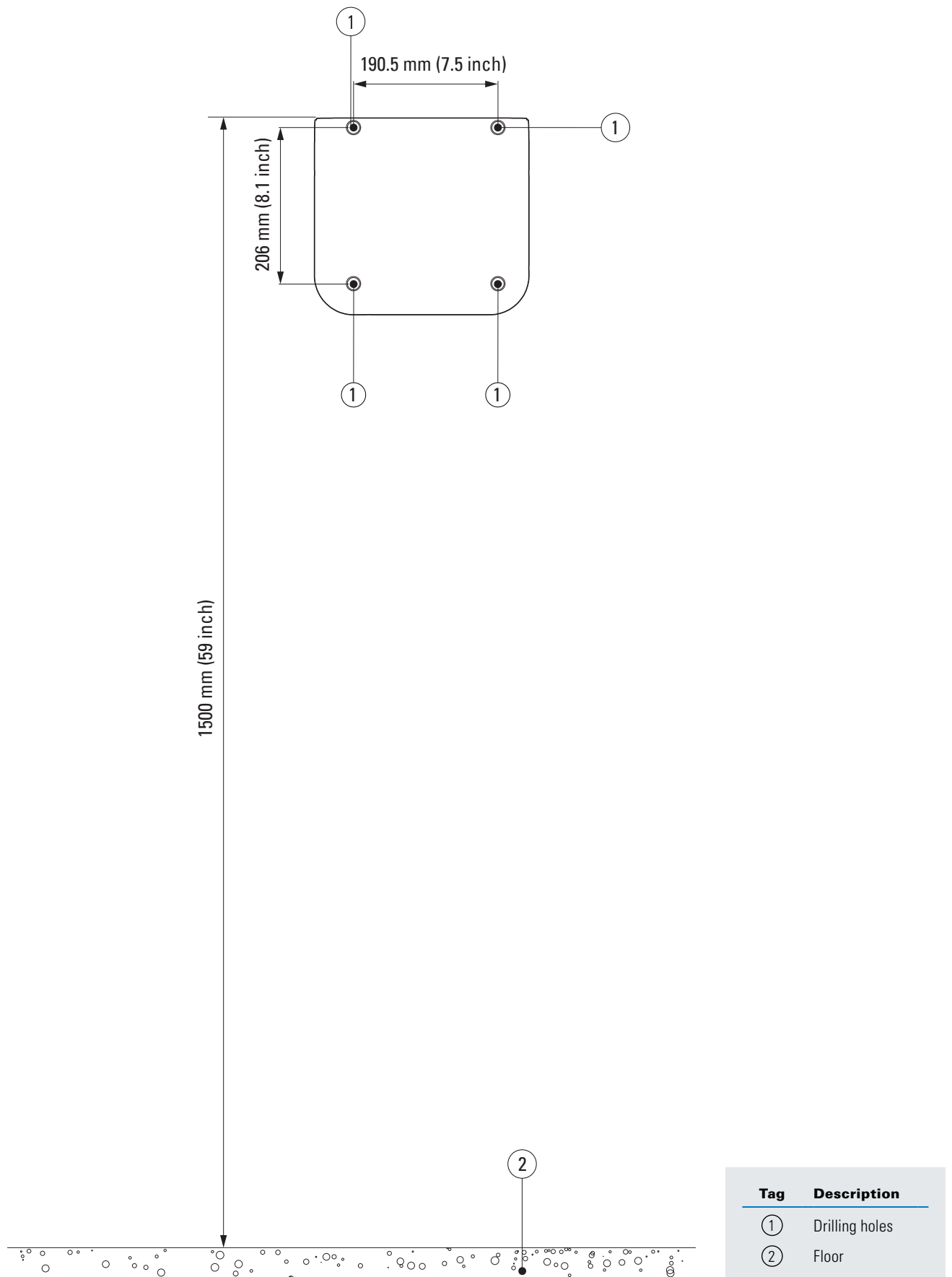
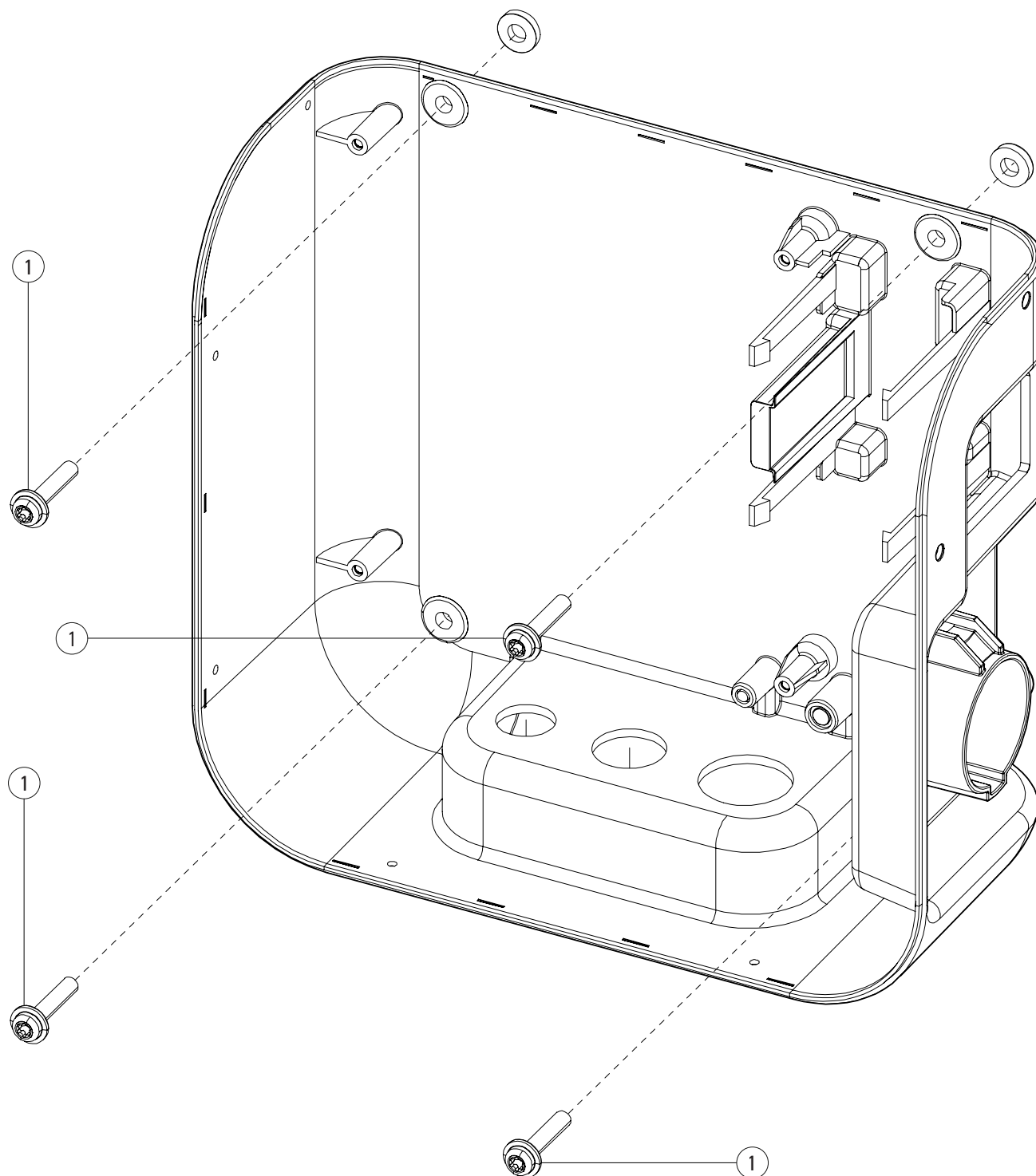

Figure 7. How to mount the Green Motion Home EV charger to a wall



Tag	Description
①	Ø6 mm screws



Electronic boards should not be removed for mounting the unit on the wall. The image is for illustration purposes only.

6. Electrical connections

6.1 Caution



Installation, commissioning, maintenance or retrofitting of the EV charger must be performed by professional and qualified personnel, who are responsible for complying with existing standards and local installation regulations.



For safety reasons, an appropriately rated input load disconnecter must be provided for each individual product. No load should be connected directly to the product during installation.



Connect only one EV charger for each circuit breaker and residual current device (RCD) (if required by local regulations). The circuit breaker serves as a mains disconnecter.



The protective earth conductor must have a cross-section at least equal to or greater than the cross-section of the cables for connection to the public grid (AC) and in accordance with the requirements of local regulations.



Before starting connection operations, ensure that the external AC-line main switch is disconnected, and circuit breakers are open.



Any operation requiring the main converter box to be opened can lead to electric shock hazards.

6.2 Standard wiring

To connect the EV charger to the electrical panel, professional and qualified personnel should consider the following guidelines and refer to Table 5.

Table 5. Overview of parameters for dimensioning of the protective devices and power supply line

Green Motion Home power range	3.7 kW	7.4 kW	11 kW	22 kW
Green Motion Home model	Green Motion Home 11 kW	Green Motion Home 22 kW	Green Motion Home 11 kW	Green Motion Home 22 kW
Input voltage	230 V (1P)	230 V (1P)	400 V (3P)	400 V (3P)
Power supply terminal block max. section (2)	10 mm ²	10 mm ²	10 mm ²	10 mm ²
Type A RCD protection at panel according to IEC 61851-1:2017	30 mA	30 mA	30 mA	30 mA
Rated current at panel	20 A	40 A	20 A	40 A

⁽²⁾ Rigid wires are recommended for the power supply. These cross sections must be re-assessed by professional and qualified personnel depending on the length of the wires.



The power losses on the power supply line must be less than +/- 10 percent of the rated power in accordance with IEC 60038 and local standards. Hence, the cable sections or line length must be reassessed by professional and qualified personnel in accordance with maximum power loss regulations. Also, when dimensioning the power supply line, observe the possible reduction factors and the increased environmental temperatures inside the connection area of the EV charger. See the temperature rating of the supply terminals. Under certain circumstances, this can increase the cable cross-section and change the temperature resistance of the power supply line.



Professional and qualified personnel must define the types of RCD and circuit breaker.



Each EV charger must be connected via a separate RCD/fault-current circuit breaker. No other consumers may be connected to this circuit.

The circuit breakers and the power cable minimal cross-sections should be defined by professional and qualified personnel.

During installation, other important issues such as "cascading" of RCDs and selection of a suitable line circuit breaker must be considered.



When dimensioning the line circuit breaker, the increased ambient temperatures in the control cabinet must also be considered. Under certain circumstances, this can make a reduction of the charging current specification necessary in order to increase the system availability.

The electrical connection is made on the power supply terminals located at the bottom of the charger. Refer to Figure 8 to wire the EV charger to the power supply.

Figure 8. The Green Motion Home EV charger wiring diagram

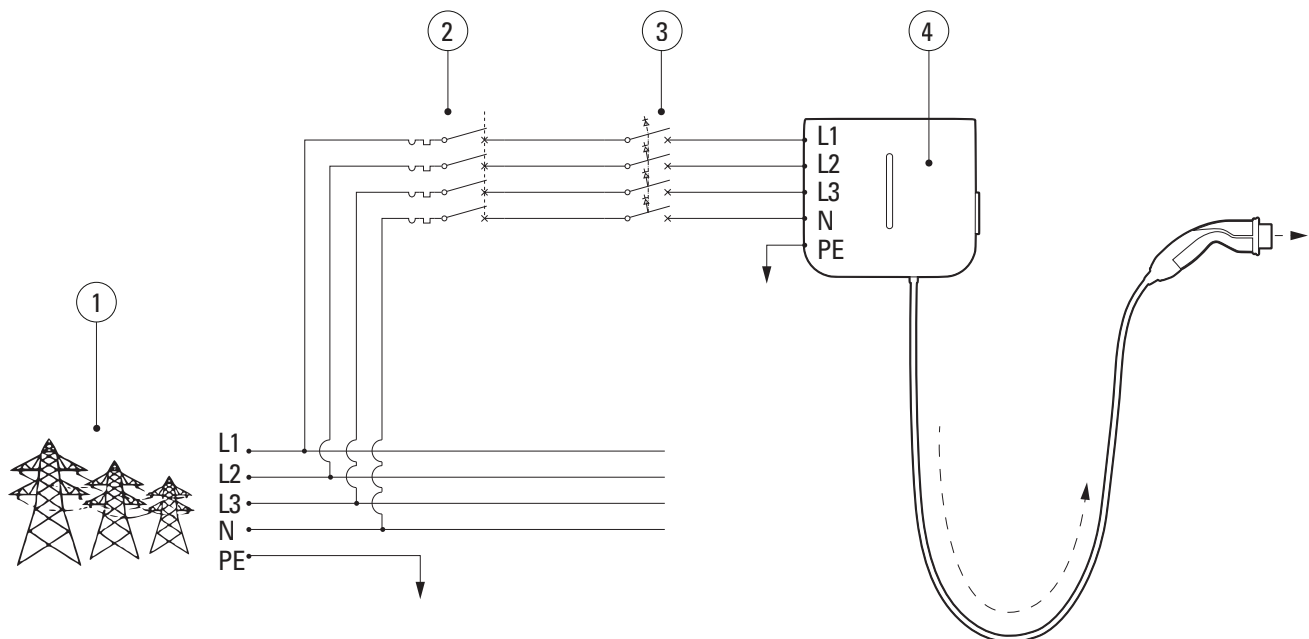

Tag	Description
①	Grid
②	Circuit breaker
③	Type A RCD according to IEC61851-1:2017
④	Green Motion Home EV charger

Eaton recommends the use of the following equipment as protective devices.

Table 6. Eaton recommendations for protective devices for the Green Motion Home EV charger

Type	Reference
40 A breaker for the three-phase 32 A charging current	PLSM-C40/3N-MW
20 A breaker for the three-phase 16 A charging current	PLSM-C20/3N-MW
RCD type A (if requested) for the three-phase 32 A charging current	PFIM-40/4/003-A-MW
RCD type A (if requested) for the three-phase 16 A charging current	PFIM-25/4/003-A-MW
20 A RCBO (MCB+RCD Type A) for the three-phase 16 A charging current	MRB4-20/3N/C/003-A
20 A breaker for single-phase 16 A charging current	EMCH120
40 A breaker for single-phase 32 A charging current	EMCH140



The installer should refer to local installation regulations to select the correct protection device.

6.3 Electrical connection and terminals



Before starting the connection operations, ensure that the external AC-line main switch is disconnected, and circuit breakers are open.

The electrical cable can reach the terminals from the top or from the bottom. Please refer to the appropriate section of this manual to open the Green Motion Home housing.

The power supply cable can be inserted through the cable gland on the bottom of the EV charger. Remove the cable glands, if necessary.



In case of three phases, connect the phase (L1, L2, L3), neutral (N) and earth (PE) wires of the AC (distribution) grid to the power supply terminal block in the Green Motion Home EV charger, respecting the (distribution) grid to the power supply terminal block, respecting the correct assignment:

- Phase (L1) → L1 terminal
- Phase (L2) → L2 terminal
- Phase (L3) → L3 terminal
- Neutral (N) → N terminal
- Earth (PE) → PE terminal



In case of single phase, connect the phase (L1 OR L2 OR L3), neutral (N) and earth (PE) wires of the AC (distribution) grid to the power supply terminal block, respecting the correct assignment:

- Phase (L1) OR Phase (L2) OR Phase (L3) → L1 terminal
- Neutral (N) → N terminal
- Earth (PE) → PE terminal



Be careful not to confuse the phases with the neutral. The device can malfunction in case of incorrect wiring.

It is prohibited to connect the unit terminals to a circuit with a 3-phase IT grid configuration.

Figure 9. Overview of power supply terminal block inside the Green Motion Home EV charger with connected phase (L1, L2, L3), neutral (N) and earth (PE) wires

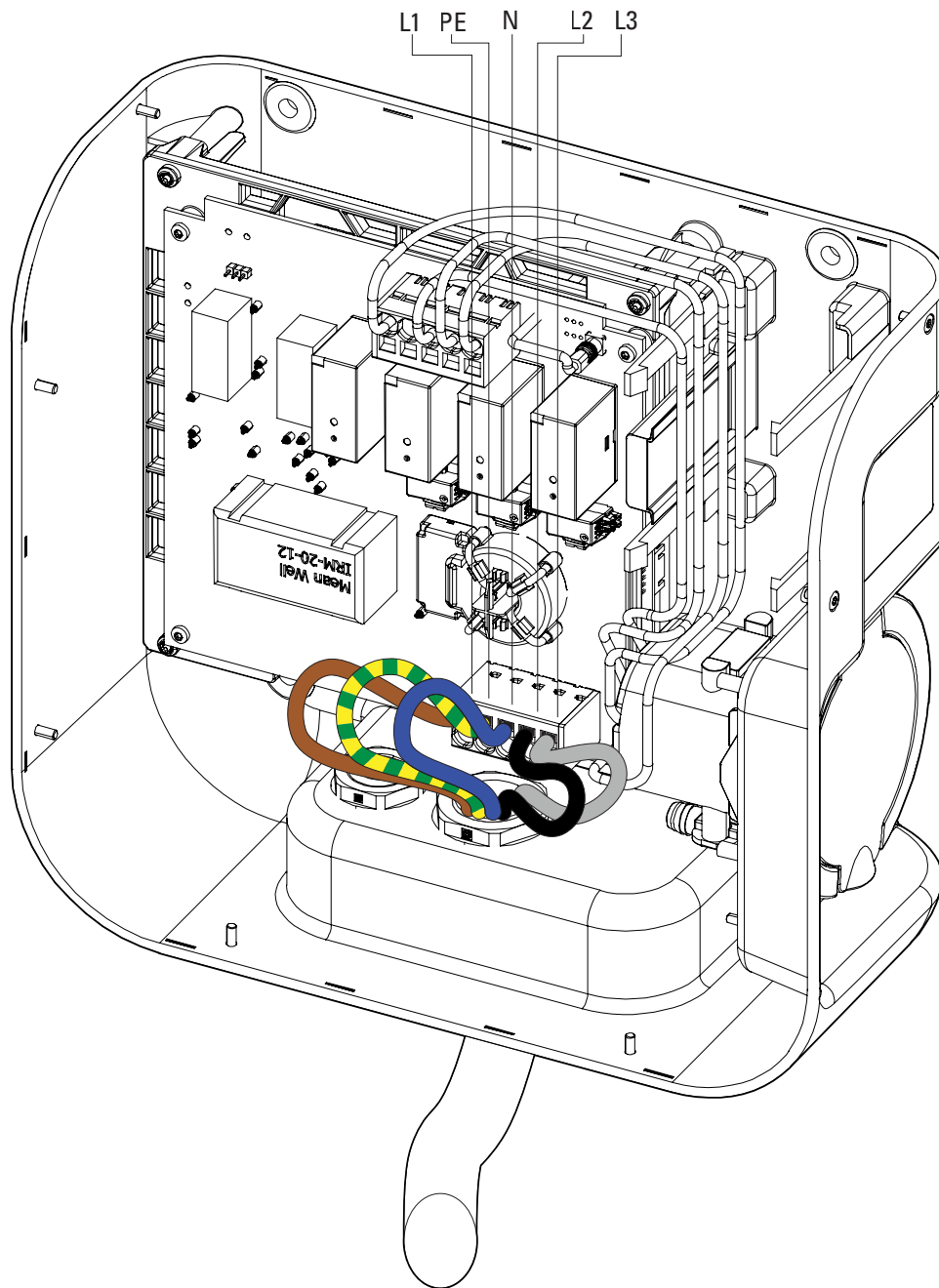
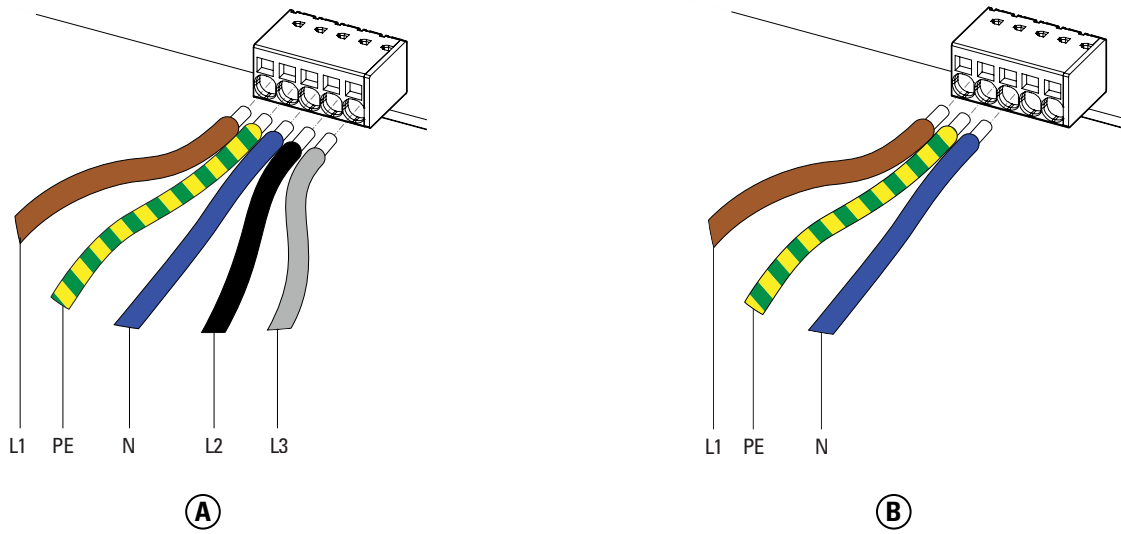

Figure 10. How to wire AC distribution grid wires to the power supply terminal of the Green Motion Home EV charger



Tag	Description
(A)	Three-phase terminals L1, L2, L3, N and PE
(B)	Single-phase terminals L1, N and PE

6.4 Charging current limitation



The charging current is limited to:

- 16 A for Green Motion Home 11 kW,
- 32 A for Green Motion Home 22 kW.

You can further limit this current through a switch located on the backside of the Green Motion Home front cover.

Figure 11. LED-Panel (PCB) located on the backside of the Green Motion Home EV charger front cover

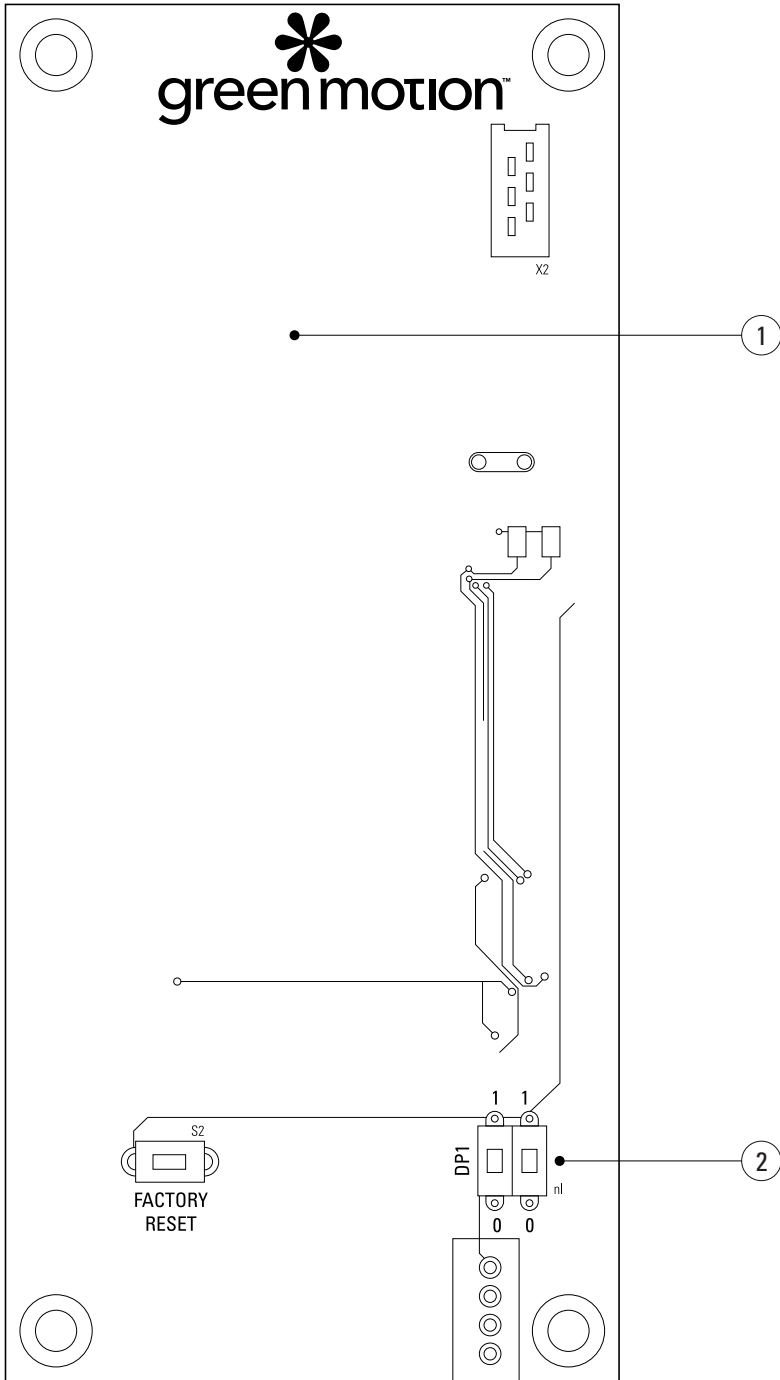

Tag	Description
①	LED Panel (PCB)
②	DIP Switch 1 to limit the output power

Refer to Table 7 to select the appropriate configuration of the unit depending on the maximum capacity of your electrical installation.



Please note: the switch positions in Table 7 are given for an orientation where the label DP1 is located on the left side of the switch.

Table 7. Configuration to limit maximum capacity of the Green Motion Home EV charger

Green Motion Home version: 11 kW	Green Motion Home version: 22 kW	Switch position
8 A	16 A	
10 A	20 A	
13 A	26 A	
16 A (Default factory configuration)	32 A (Default factory configuration)	

In the event of damage caused by improper current adjustment, the product warranty is void and no returns will be accepted. Eaton declines any responsibility for improper current adjustment and cannot be liable for any inappropriate operation.

6.5 Installation of an external switching device

EV-ready compliance requires that the EV charger can execute an emergency stop in case of contactor failure.

In Italy and Netherlands, it is also required by IEC61851-1 that EV chargers equipped with no-shutters outputs (cable or T2 socket) execute an emergency stop in case of contactor failure.

In order to execute an emergency stop, the circuit breakers of the Green Motion Home EV charger need to be equipped with a tripping coil/shunt trip, a device designed to switch the circuit breakers off remotely. The shunt trip should have a DC voltage rating of 24 V and should be connected on the supply lead control wire, connected to the E terminal of the EV charger. See the wiring diagram in Figure 12.

For EV-ready compliance the installation process should be done by an EV-ready certified installer and following the requirements listed in this section.

6.5.1 Grid connection

Connect the EV charger to the electrical panel with the protections as per Table 8.

Table 8. Recommendations for protections for the Green Motion Home EV charger

Power range	3.7 kW	7.4 kW	11 kW	22 kW
Model	Green Motion Home 11 kW	Green Motion Home 22 kW	Green Motion Home 11 kW	Green Motion Home 22 kW
Input voltage	230 V (1P)	230 V (1P)	400 V (3P)	400 V (3P)
Power supply terminal block max section (3)	10 mm ²	10 mm ²	10 mm ²	10 mm ²
RCD protection at panel according to IEC 61851-1:2017	30 mA type A	30 mA type A	30 mA type A	30 mA type A
Circuit breaker at panel	20 A	40 A	20 A	40 A

⁽³⁾ Rigid wires are recommended for the power supply. These cross sections must be re-assessed by professional and qualified personnel depending on the length of the wires.



Refer to Section 6.2 for recommendations regarding the connection to the grid.

If the earthing system is a TT or a TN, the ground resistance must not exceed 100 Ohms.

Power supply can be protected with a surge protection device type 2.

Figure 12. The Green Motion Home EV charger wiring diagram for EV-ready standards

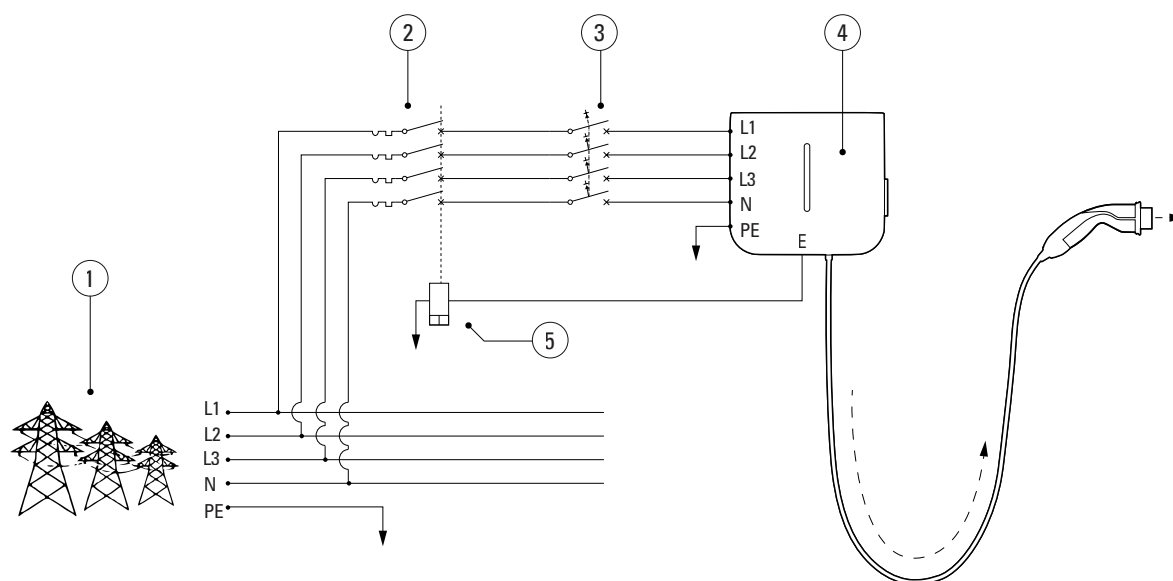

Tag	Description
①	Grid
②	Circuit breaker
③	Type A RCD according to IEC 61851-1:2017
④	Green Motion Home EV charger
⑤	Shunt trip

6.5.2 Installation of an external switching device

Eaton recommends the use of the following tripping coil/shunt trip:

Table 9. Recommended tripping coil/shunt trip

Type	Eaton reference
Tripping coil/Shunt Trip	ZP-ASA/24



Please be advised that the recommended tripping coil/shunt trip ZP-ASA/24 will not fit onto a one module sized, 1P+N circuit breaker.

The terminal E (Emergency) is located on the Control unit (CU). To connect your shunt trip to the Green Motion Home EV charger follow these steps:

Step 1. Ensure unit is powered off and load is dis-connected.

Step 2. Wire the mating connector. Mating connector reference:

- Manufacturer: Weidmuller (Pluggable Terminal Blocks B2L 3.50/20/180 SN BK BX)
- Manufacturer part number: 1727710000

Step 3. Locate the header J9.



The mating connector is not provided with the charger and is to be obtained separately.

Figure 13. J9 mating connector

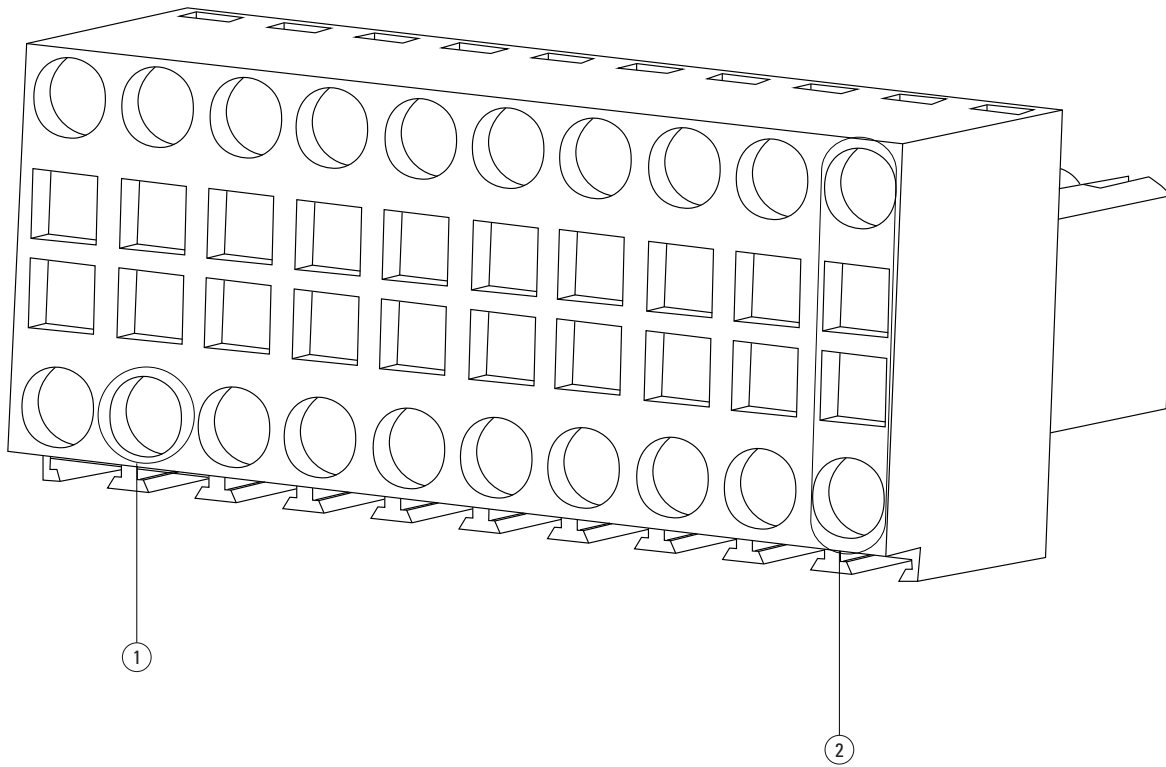

Tag	Description
①	Pin 4 → E
②	Pin 19 or 20 → GND

Step 3. Open the Green Motion Home EV charger. See section 5.2.

Step 4. Locate the header J9 on the electronic board (mounted on the inner side) from the top of the charger.

Figure 14. Location of the AC platform

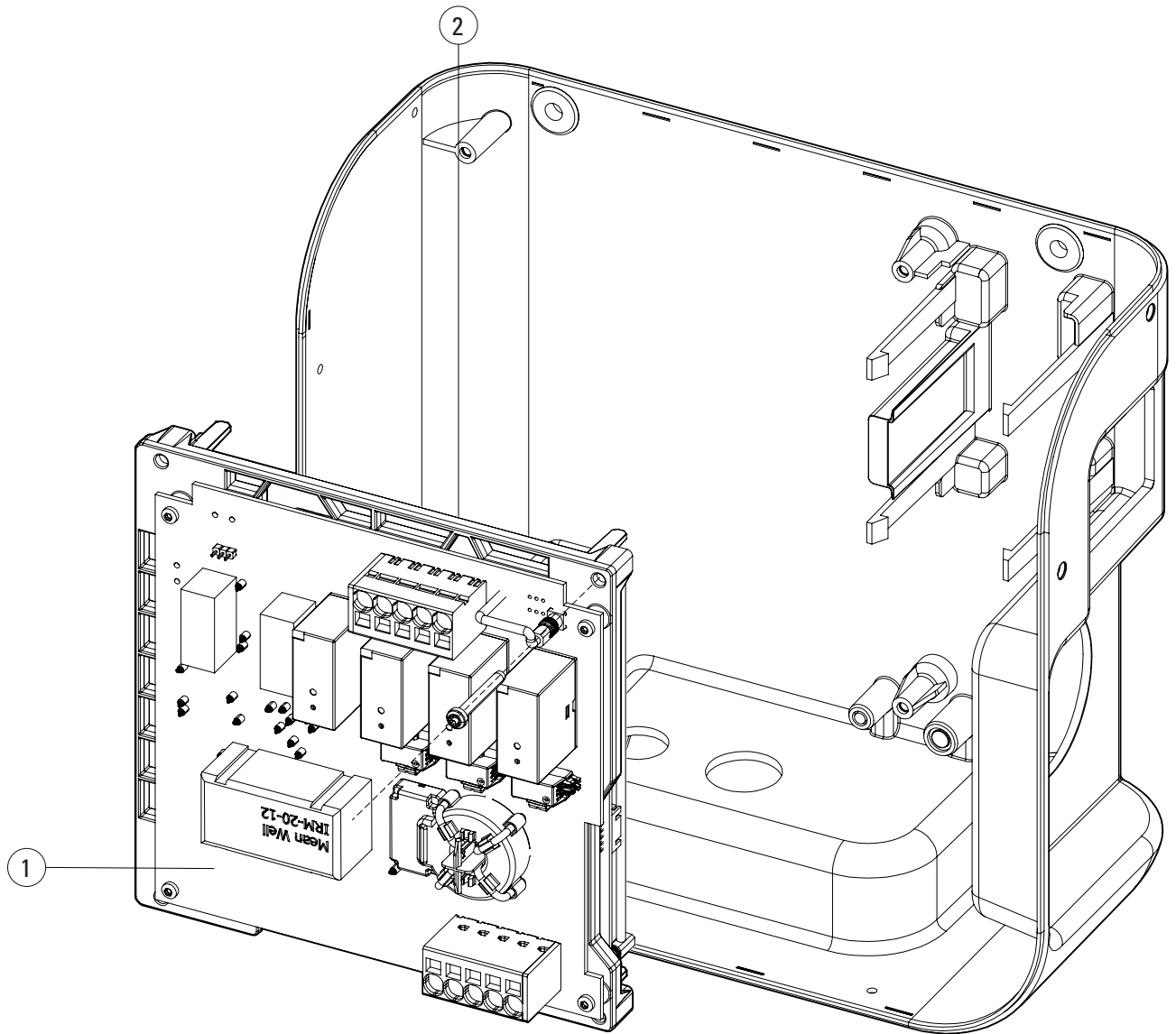

Tag	Description
-----	-------------

- | | |
|---|--|
| ① | AC platform |
| ② | Header J9 (on the backside of the AC platform) |



Electronic boards should not be removed. The image is for illustration purposes only.



Make sure to wear appropriate PPE to perform the operation.

Figure 15. Top view showing the position of the J9 connector on the AC platform

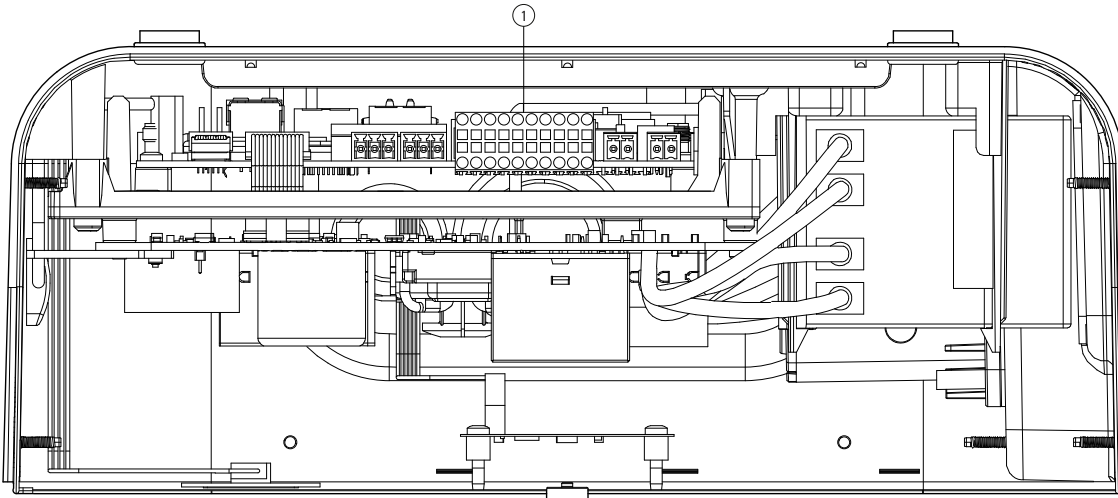

Tag	Description
①	J9 mating connector

Step 5. Correctly orient the connector with edge of the PCB. Plug in the mating connector carefully.

Figure 16. Proper alignment of the mating connector

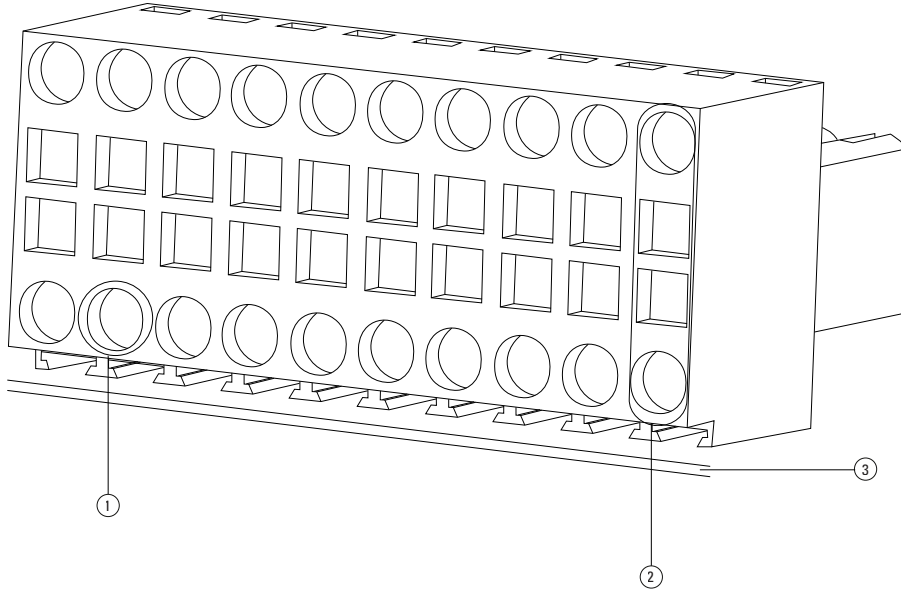

Tag	Description
①	Pin 4 → E
②	Pin 19 or 20 → GND
③	Edge of PCB



Take note of connector orientation with respect to the PCB edge. The device can malfunction in case of incorrect wiring.

Step 6. Connect the wires to the shunt trip by passing through the communication cable gland at the bottom of the EV charger. Carefully route the wires, making sure the wires do not touch the AC boards.

Figure 17. Bottom view of the Green Motion Home EV charger

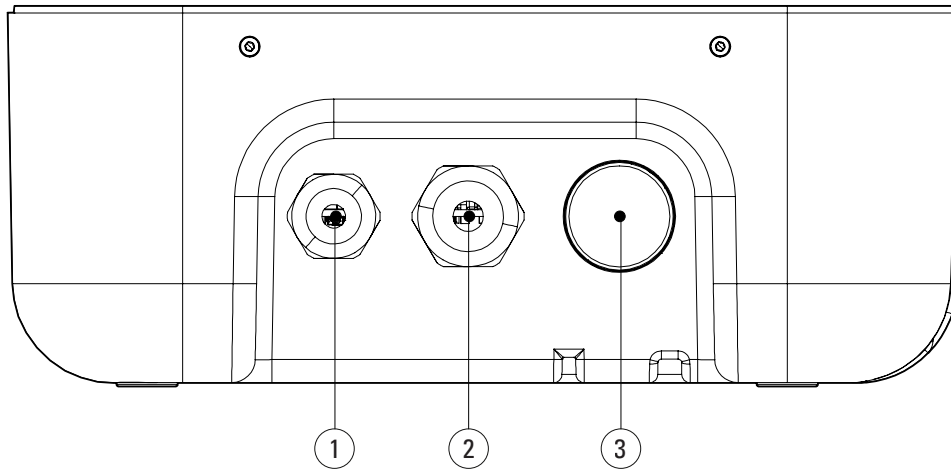

Tag	Description
①	Communication cable gland
②	Power input
③	Cable output

Step 7. Carefully reassemble the platform and close the Green Motion Home EV charger. If after installation of the shunt trip a contactor failure occurs in the EV charger, the EV charger enters a fault mode. The LED indicator on the front cover turns red. See Section 7.2. After a few seconds, the emergency output activates the shunt trip, switching off the circuit breakers.

6.5.3 Verification

Check the following points to provide evidence and to demonstrate the compliance of the EV charger with EV-ready standards:

Harmonic distortion and unbalanced loading on the electric power supply:

The electric power supply must imperatively comply with the international standards IEC 61000-2-1, 61000-2-2, EN 50160 § 4.2.4 and § 4.2.5.

Low frequency conducted disturbances in the power supply up to 150 kHz ‘supraharmonics’:

The noise level in the frequency band 0 kHz – 150 kHz (excluding harmonics) shall not exceed 4 % of the phase to neutral voltage.

If these points cannot be verified, the installation must be adapted to comply with the standards (additional filter, different electrical connection etc...).

If this condition is not met, then a separating transformer must be installed upstream of the EV charger.

6.5.4 Current settings for EV-ready compliance

To be EV-ready compliant, one of the requirements for an EV charger is that it can provide minimum charging current to the vehicle. The installer must ensure that the EV charger's maximum current limit settings (via DIP switch) respect the EV-ready minimum current requirements.

Please refer to Table 10 for the maximum current settings applicable to an EV-ready installation.

Table 10. Switch settings for EV-ready compliance

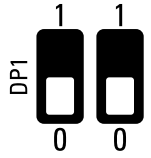
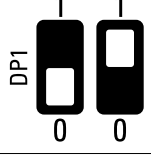
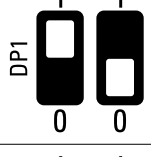
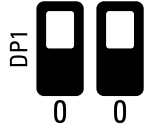
Green Motion Home version: 11 kW (1P)	Green Motion Home version: 11 kW (3P)	Green Motion Home version: 22 kW (1P)	Green Motion Home version: 22 kW (3P)	DIP switch
OK	Not OK	OK	OK	
OK	Not OK	OK	OK	
OK	OK	OK	OK	
OK	OK	OK	OK	

In the event of damage caused by improper current adjustment, the product warranty is void and no returns will be accepted. Eaton disclaims any responsibility for improper current adjustment and cannot be held liable for an inappropriate operation.

7. Commissioning



Professional and qualified personnel must be experts in the field and are therefore responsible for commissioning the system in accordance with the manufacturer's instructions and local legislation.

7.1 Green Motion Home switch-on



Before switching on the EV charger, check the effectiveness of the safety measure(s) of the system in accordance with the local regulations.

Electrical systems or devices must be checked by professional and qualified personnel before commissioning and switching on the unit.

Before switching on the unit, please perform the checks below:

- Step 1.** Check that the equipment is correctly fixed to the wall or to the floor in accordance with local regulations.
- Step 2.** Check that the AC grid connections have been made correctly in accordance with local regulations.
- Step 3.** Perform checks on the continuity of the connections of the protective conductor, insulation resistance, RCD triggering current, triggering time, etc., in accordance with local regulations.
- Step 4.** Check that the maximum current limit has been set correctly as per the installation requirements.
- Step 5.** Check that the connection cover is closed and secured with the fixing screws.



If the checks listed above were satisfactory, proceed as follows:

- Step 1.** Turn on the AC grid circuit breakers.
- Step 2.** Wait for the LED light to come on.
- Step 3.** Please visit the link or scan the QR code to fill out the installation checklist form at: <https://content.eaton.com/en-gb-installation-checklist-ev-chargers>

Figure 18. QR code for installation checklist online form



7.2 LED indicator

The list below summarizes the possible LED indications and their significance during operation of the Green Motion Home EV charger.

Figure 19. LED indicator of the Green Motion Home EV charger

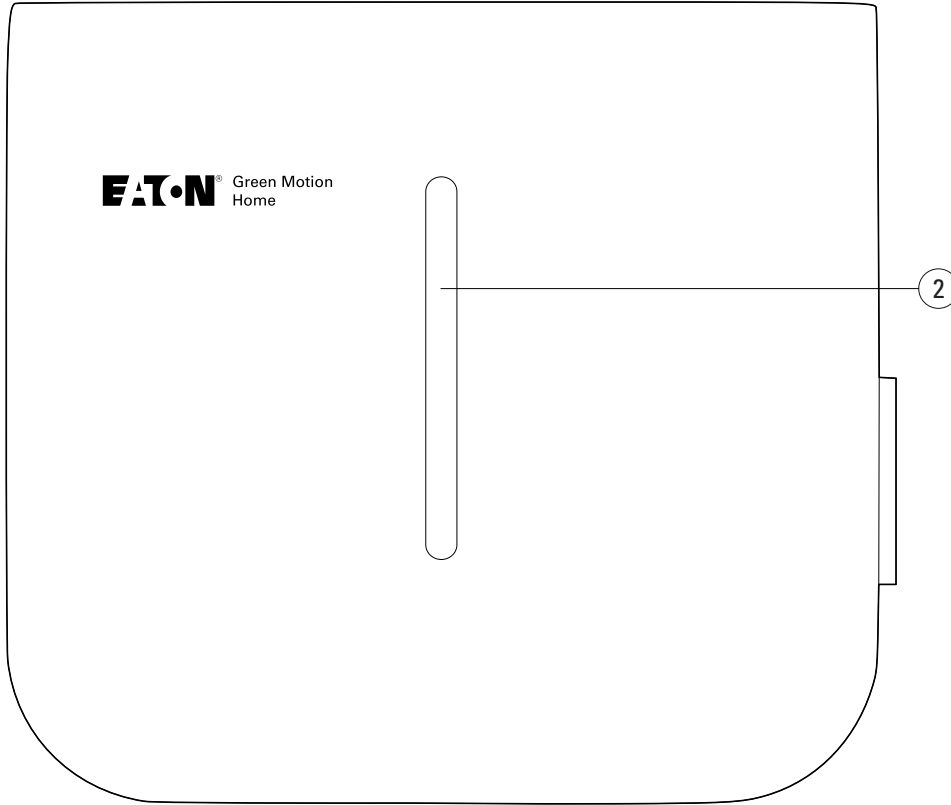

Tag	Description
①	LED indicator

Table 11. LED indication

LED Color	LED state	Description
Green	Solid	EV charger ready for use
Green	Pulsing	EV charger is waiting for user command to start via app
Blue	Solid	The vehicle is fully charged/vehicle charging limit reached
Blue	Pulsing	Charging session is initializing
Blue	Progress	Charging in progress
Red	Solid	Charging error or mechanical fault. Try restarting from the fuse box. Contact technical support if the issue persists
Red	Flashing	Action failed, try again. Contact technical support if the issue persists
White + Red dot	Flashing	Network error. EV charger cannot connect to the Internet/back-end. Check that the Wi-Fi is connected and the password has not been changed.
Orange	Pulsing	An update is in progress
No Light	N/A	EV charger has no power

7.3 Eaton Green Motion Charger controller application

Download the Eaton Green Motion Charger controller application using the QR code shown in Figure 20 to control the Green Motion Home EV charger remotely and take advantage of additional features.

Figure 20. QR code for iOS app and Android app download

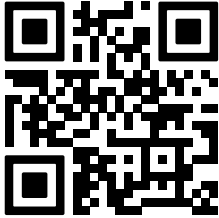

After pairing with the Green Motion Home EV charger, the application enables the EV user, among others, to:

- Start a charging session,
- Stop a charging session,
- Monitor energy consumption during charging,
- And more.

For more information on how to use the application, please refer to the instructions in the application or consult the product documentation on www.eaton.com

7.4 Removing the plug

To remove the plug from the holder you need to pull it first vertically then horizontally. See Figure 21.

Figure 21. Removing the plug from the Green Motion Home EV charger

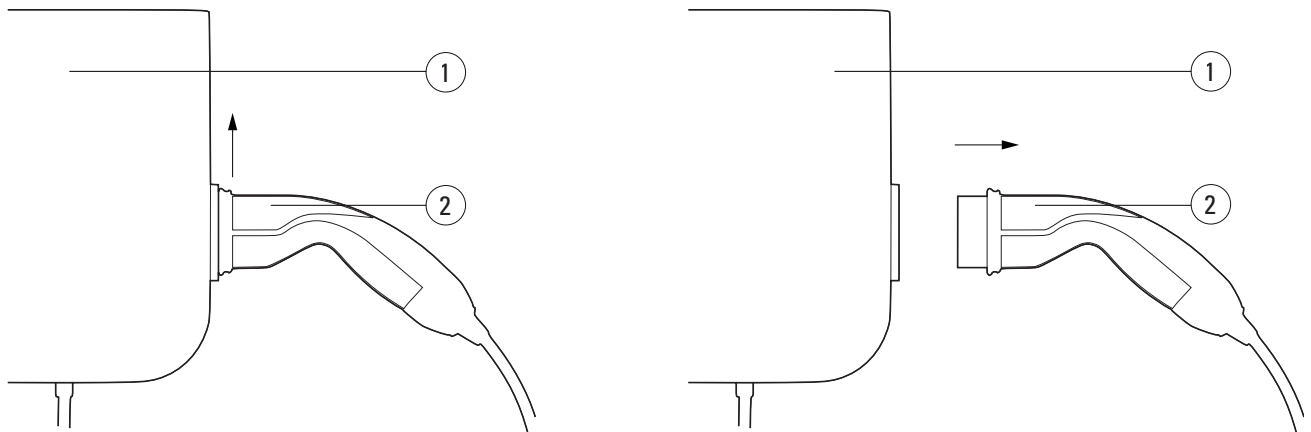

Tag	Description
①	Green Motion Home EV charger
②	Type 2 connector

8. Maintenance



Installation, commissioning, maintenance or retrofitting of the EV charger must be performed by professional and qualified personnel, who are responsible for complying with existing standards and local installation regulations.



Before starting connection operations, ensure that the external AC-line main switch is disconnected, and circuit breakers are open.



Any operation requiring the main converter box to be opened can lead to electric shock hazards.

The opening of the EV charger as well as any configuration changes must be carried out by professional and qualified personnel in accordance with the local safety and electrical regulations and laws.

Wait at least 10 minutes before removing the Green Motion Home EV charger. The enclosure could overheat during its operation or be heated by direct sunlight. To avoid burns from an overheated surface caused by sunlight, please use suitable PPE or wait for the equipment to cool down before accessing it.

8.1 Factory reset

The Green Motion Home EV charger provides the ability to restore the charger to its default factory configuration. It can be used to erase logs from the charger's memory when decommissioning the unit.



Since the unit will be opened in the powered state to perform the factory reset, only qualified personnel (trained according to IEC 60050-826:2004, 826-18-01), using appropriate personal protective equipment, may perform the operation.

Steps to perform the factory reset:

- Step 1.** Power off the unit. Disconnect any load.
- Step 2.** Wait at least 10 minutes for the unit to cool down.
- Step 3.** Open the housing by removing the fixing screws. Refer to Section 5.2 for details
- Step 4.** Remove the front cover safely. Do not remove any wiring
- Step 5.** Locate the push button on the LED board.
- Step 6.** Power on the unit.
- Step 7.** Wait for the LED indicator on the unit to turn green.
- Step 8.** Press and hold the Factory Reset button for 10 seconds until the charger reboots.
- Step 9.** Power off the unit.
- Step 10.** Close the front cover.

Figure 22. LED-Panel (PCB) located on the backside of the Green Motion Home EV charger front cover

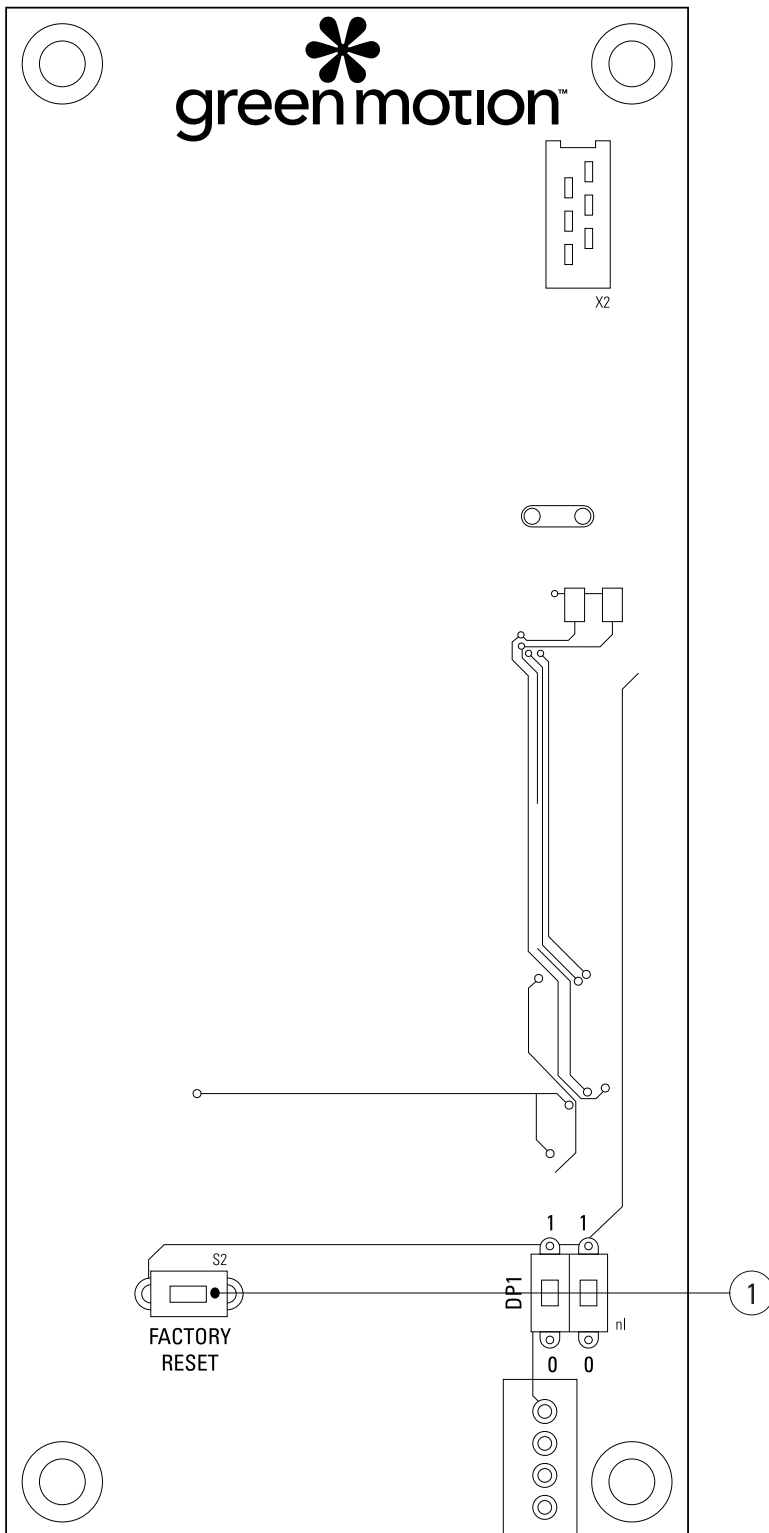

Tag	Description
-----	-------------

- | | |
|---|----------------------|
| ① | Factory reset button |
|---|----------------------|

8.2 Uninstall



Before starting the connection operations, make sure that the charging cable is not connected to the vehicle, that the external AC-line main switch is turned off and that the circuit breakers are open.

Wait at least 10 minutes before removing the Green Motion Home EV charger.

The enclosure could overheat during its operation, or be heated by direct sunlight, and it can cause burns on contact. To avoid burns from a hot surface caused by sunlight, please use suitable PPE or wait for the equipment to cool down before accessing it.

To uninstall the unit:



Step 1. Disconnect any load.

Step 2. Open the housing by removing the fixing screws.

Step 3. Perform factory reset operation on the charger.

Step 4. Disconnect the AC grid connectors.

Step 5. Unscrew the mounting screws.

Step 6. Close the front cover to avoid any injuries from sharp edges.

8.3 EV charger updates



It is mandatory to install and maintain the unit with the latest system update to enable new features and bug fixes. Failure to do so will void the warranty.

For chargers in online mode (connected to the Internet), the EV charger will update automatically when an update is available.

For chargers in offline mode (not connected to the Internet), the mobile application will inform about the availability and update process.



EV charger will not perform an upgrade while an active charge session is in progress.

EV charger will be unavailable for charging while downloading the upgrade package and upgrading the system.

Please contact an Eaton technical support representative for any queries using the email address:

support@greenmotion.ch

8.4 Disposal

When disposing of the EV charger, the end user should contact professional and qualified personnel for disposal instructions. Please refer to www.eaton.com for further details.



The EU Directive on Waste Electrical and Electronic Equipment (WEEE) (Directive 2012/19/EU) establishes common rules on the management of electrical and electronic equipment to minimize its impact – from design until disposal – on the environment. As a manufacturer of electrical and electronic equipment, Eaton actively supports the requirements of the WEEE Directive.

In compliance with the EU standard EN 50419 for marking of electrical and electronic equipment, we include the crossed-out wheeled bin symbol on our products. This symbol alerts users that these products should be recycled in accordance with local environmental regulations and not discarded with household waste. When end users recycle WEEE they are helping to ensure that these products are neither incinerated nor sent to landfill, minimizing the potential negative impact on human health and the environment.

Any device that is no longer needed must therefore be returned to the distributor or disposed to an authorized collection point or recycling center in the area. Eaton encourages all its customers and end users to make responsible decisions when it comes to disposing products.

Eaton is not responsible for the transportation of the device to the collection point or recycling center.

9. Troubleshooting



This section contains information and procedures for solving possible problems that may occur with the Green Motion Home EV charger.

If the problem persists, contact your Eaton technical support representative using the email address support@greenmotion.ch

Possible problems	Solutions
The EV charger is unresponsive; nothing happens when connecting it to a vehicle.	Check that the EV charger is correctly connected to a power supply. The LED indicator should be solid green.
The EV charger LED indicator is solid red.	There is an error or fault preventing a charging session to either start or resume. Attempt to reinitiate the charging session by unplugging the charging cable from the vehicle and reinserting it. If the problem persists, check any control messages displayed in the vehicle.
The EV charger LED indicator is green, but the vehicle does not charge.	Check that the charging cable connector is adequately plugged into the vehicle. When charging with a Type 2 connector, ensure that it is pushed in until an audible click is heard. Some vehicles need to be locked before a charging session is allowed to start. Try locking the vehicle. Visually inspect the condition of the cable used for charging, its connector and sockets, the vehicle socket as well as the EV charger socket if using a Green Motion Home EV charger with a Type 2 female socket. Stop usage immediately if you see physical damage to any of these parts. Check that the vehicle does not have scheduled/delayed charging set up. In such cases it will only charge at certain hours of the day.
The charging cable connector will not release from the vehicle or the EV charger.	In most cases the charging cable must first be released/unlocked by the vehicle to prevent injuries, accidental disconnection and misuse. Try unlocking the vehicle first. Alternatively, refer to the vehicle instruction manual.
The plug for the 22 kW model does not release.	Due to the weight of the 22 kW connector cable, it is possible that the latch on your vehicle will not release. In this case, firmly hold the plug slightly upwards as you disconnect the plug from the vehicle.

10. Technical data

10.1 Rating plate



To locate the rating plate on the equipment, refer to Figure 23.

The technical specifications shown in this manual do not replace those that appear on the rating plate attached to the equipment.



The labels attached to the equipment must NEVER be removed, damaged, soiled or hidden for any reason.

The labels must NOT be hidden by foreign objects (rags, boxes, equipment, etc.).

They must be cleaned periodically and always kept clearly visible.

Information reported on the rating plate:

1. Manufacturer
2. Model
3. Serial number
4. Ratings
5. Warnings and usage instructions

Figure 23. Location of the rating plate on the bottom of the Green Motion Home EV charger

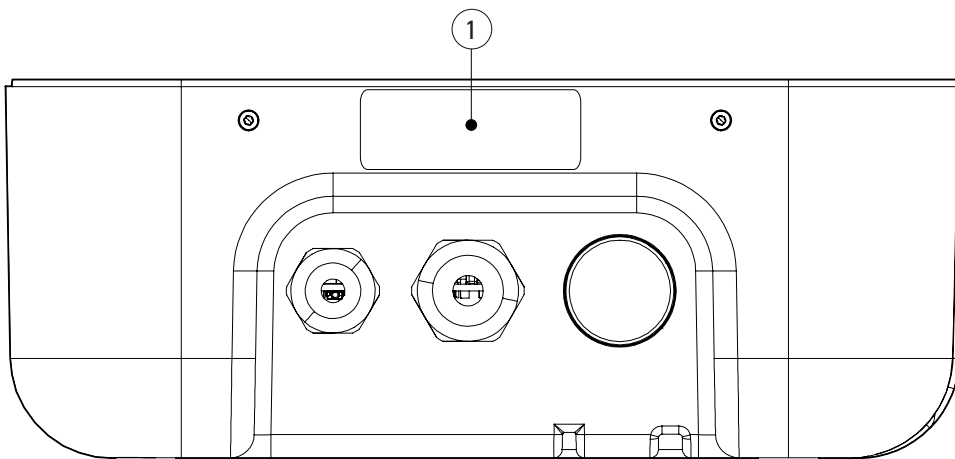

Tag	Description
①	Rating plate

Figure 24. Example of the Green Motion Home rating plate

Electric Vehicle Charging Station

xCIH V2 3.7-22 kW Cable Type 2 On-Line

Catalogue Nb:XCI3272221-03000

S/N:TH33M34001

Rated Voltage: AC 230 - 400V 50 Hz 3L + N + PE

Rated current: AC 32A

Rated temperature: -25°C to +45°C IP 54



CE COMPLIANCE CONTACT:

Eaton I.F.

110 rue Blaise Pascal

38330 Montbonnot St Martin

France



ENGINEERED IN SWITZERLAND
MADE IN SWITZERLAND

10.2 Technical datasheet

The latest version of the technical datasheet for the Green Motion Home EV charger as well as its CE Certification document are available for download on www.eaton.com.

Table 12. List of standards Green Motion Home EV charger complies with

Certifications and standards	
Product Safety	Mode 3 in accordance with EN/IEC 61851-1 AC charging
Cable	Type 2 cable: up to 32 A/400 V AC in accordance with EN/IEC 62196-1 and EN/IEC 62196-2
Electromagnetic compatibility	EN 61851-21-2, EN 61000-6-1, EN 61000-6-3, EN 61000-3-3, EN 61000-3-11, EN 61000-3-12

11. Warranty and technical support

For technical issues that arise during the warranty period for the Green Motion Building EV Charger, contact your local installer or Eaton Technical Support via the following email address: support@greenmotion.ch.

Green Motion's telephone support is available Monday through Friday from 8 a.m. to noon and from 1 p.m. to 5 p.m. (4 p.m. on Friday) CET. Tel: +41 21 544 04 46 "

The following information should be provided when contacting the Eaton technical support representative:

- Product model and serial number
- Any fault messages or error codes displayed in the Eaton Green Motion Charger controller application

