

Installation guide:
**EV single and
dual pedestals**

Scan here for
Spanish translations



Powering Business Worldwide

Green Motion EV smart breaker chargers

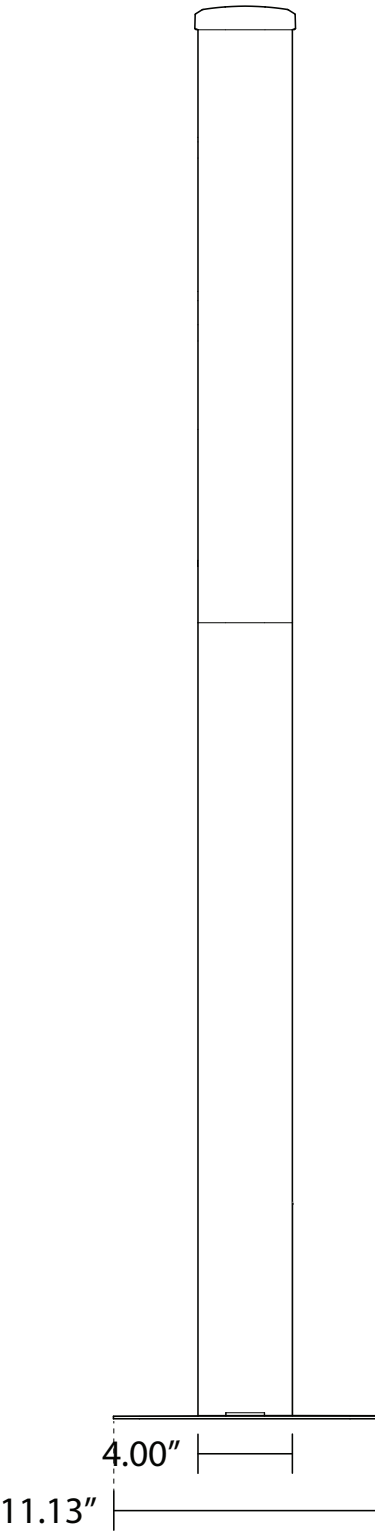
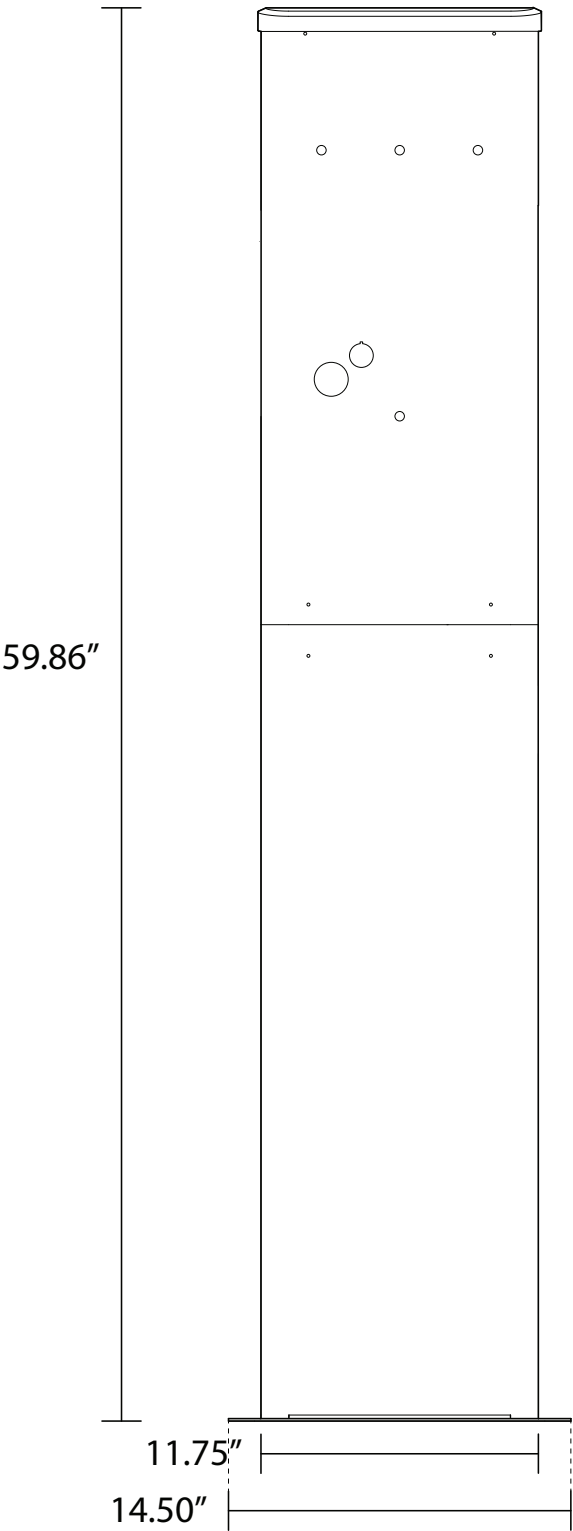

Contents

- PRODUCT INTRODUCTION 2
 - EV single port and dual port pedestals..... 2
- PACKAGE CONTENTS..... 3
 - EV single port pedestal kit 3
 - EV dual port pedestal kit 3
- INSTALLATION 4-12
 - Safety information 4
 - General reference 5
 - EV single port and dual port pedestal installation 6-12
 - A - Pour concrete pad and install anchors 6-8
 - B - Install base plate 9
 - C - Remove cover panels 10
 - D - Install EV pedestal 11
 - E - Replace cover plates 12
- TECHNICAL SPECIFICATIONS 13

EV single port and dual port pedestals



Package contents

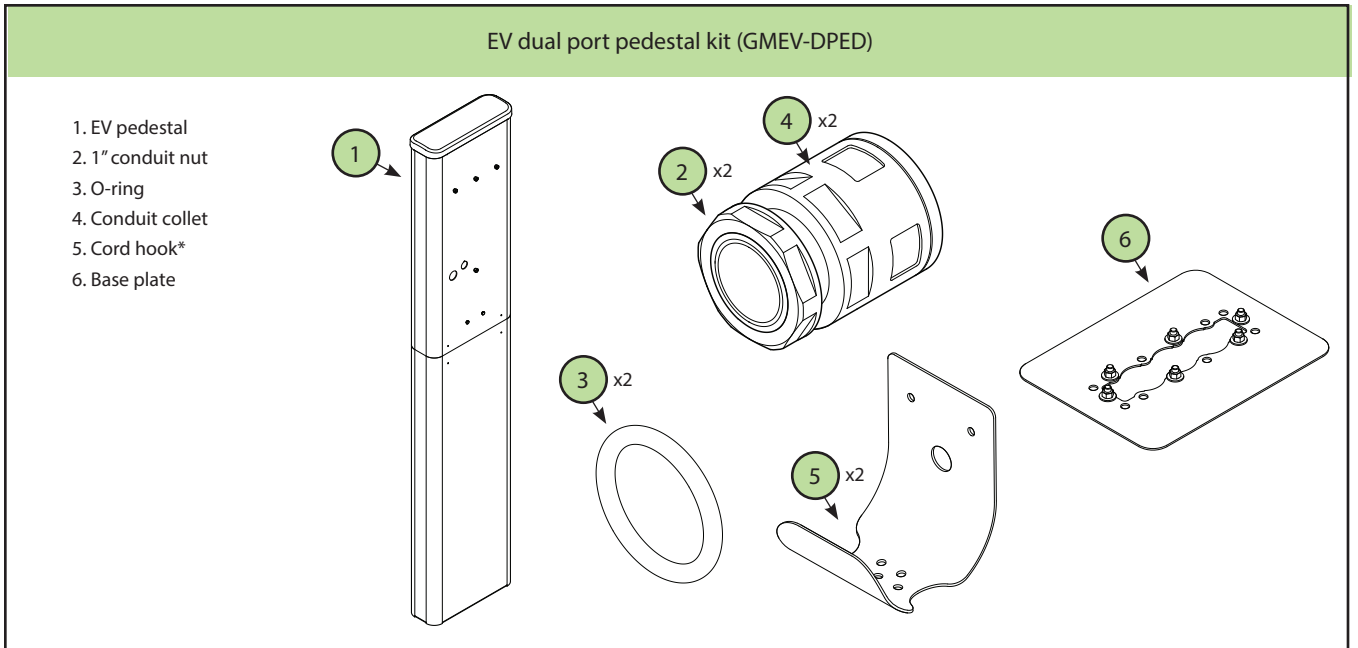
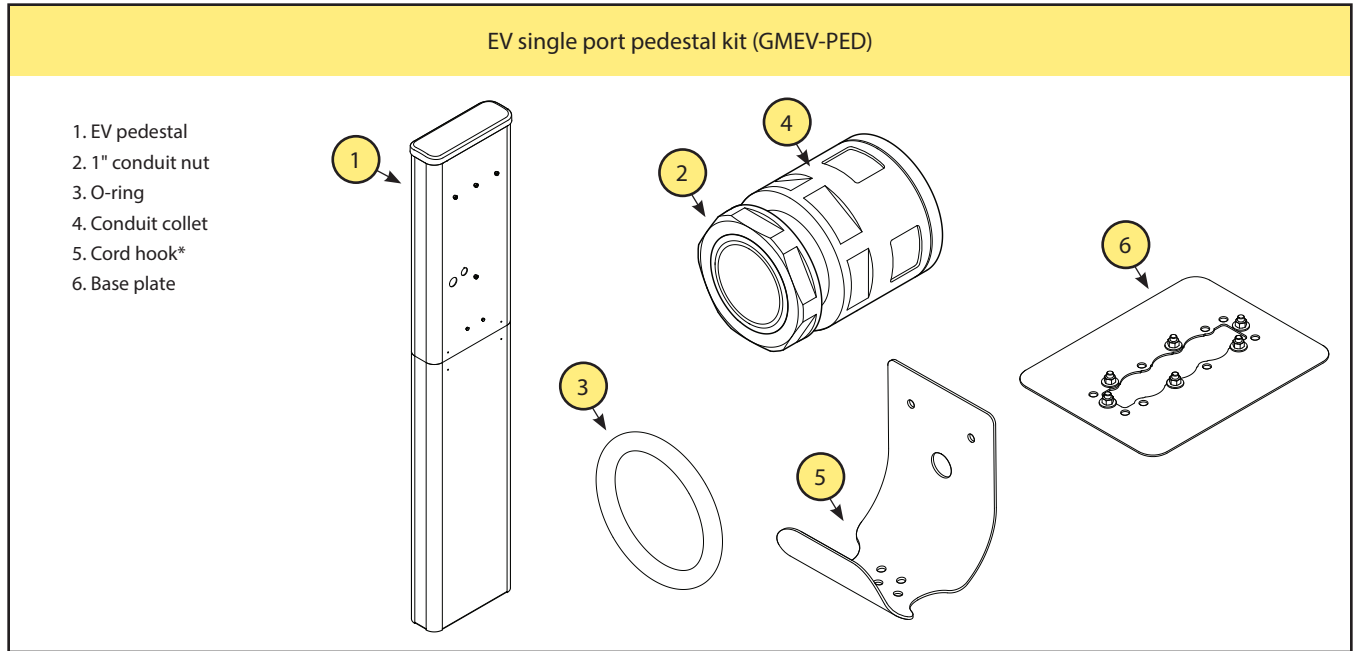

Required items not included:

- Hardware (i.e. studs or tapcons) for attaching EV pedestal to concrete - x8
- PVC pipes for running wire through concrete - x3
- Ground rod

- Wire
- Concrete
- Tools

* If your commercial EV charger comes with a premium cord holster (GMEV32HSTR-BKR) discard the cord hook provided and install the premium cord holster in its place.

Installation

Important safety instructions

DANGER

FAILURE TO FOLLOW THESE INSTRUCTIONS COULD RESULT IN DEATH, PERSONAL INJURY, OR PROPERTY DAMAGE. CIRCUIT BREAKERS MUST BE INSTALLED AND SERVICED BY A QUALIFIED ELECTRICIAN. REMOVE ALL POWER SOURCES TO THE PANEL BEFORE STARTING INSTALLATION OR MAINTENANCE.

WARNING

THIS EQUIPMENT SHOULD BE INSTALLED, ADJUSTED, AND SERVICED BY QUALIFIED ELECTRICAL PERSONNEL FAMILIAR WITH THE CONSTRUCTION AND OPERATION OF THIS TYPE OF EQUIPMENT AND THE HAZARDS INVOLVED. FAILURE TO OBSERVE THIS PRECAUTION COULD RESULT IN DEATH OR SEVERE INJURY.

READ THIS MANUAL THOROUGHLY AND MAKE SURE YOU UNDERSTAND THE PROCEDURES BEFORE YOU ATTEMPT TO OPERATE THIS EQUIPMENT. THE PURPOSE OF THIS MANUAL IS TO PROVIDE YOU WITH INFORMATION NECESSARY TO SAFELY OPERATE, MAINTAIN, AND TROUBLESHOOT THIS EQUIPMENT. KEEP THIS MANUAL FOR FUTURE REFERENCE.

DO NOT USE THIS PRODUCT IF THE EV CONNECTOR CORD IS FRAYED, HAS DAMAGED INSULATION, OR HAS ANY OTHER INDICATION OF DAMAGE.

DO NOT USE THIS PRODUCT IF THE EV SMART BREAKER CHARGER, THE EV CONNECTOR, OR THE LOADCENTER IS BROKEN, CRACKED, OPEN, OR SHOWS ANY OTHER INDICATION OF DAMAGE.

INTENDED FOR USE WITH PLUG-IN ELECTRIC VEHICLES ONLY. PREMISE VENTILATION NOT REQUIRED.

THIS DEVICE SHOULD BE SUPERVISED WHEN USED AROUND CHILDREN.

WARNING

TURN OFF OR DISCONNECT THE POWER SUPPLYING THIS EQUIPMENT BEFORE BEGINNING WORK. THIS MAY REQUIRE THAT YOU CONTACT YOUR ELECTRIC UTILITY TO DISCONNECT POWER TO AN EXISTING LOADCENTER. THE LINE SIDE OF THE MAIN BREAKER IS ENERGIZED UNLESS POWER IS DISCONNECTED UPSTREAM. EATON WILL NOT ASSUME RESPONSIBILITY FOR PROPERTY DAMAGE OR PERSONAL INJURY RESULTING FROM MISUSE OF THE INFORMATION IN THIS PUBLICATION.

NOTICE

INSTALL EQUIPMENT IN CONFORMANCE WITH CODES.

Grounding instructions

WARNING

IMPROPER CONNECTION OF THE EQUIPMENT-GROUNDING CONDUCTOR IS ABLE TO RESULT IN A RISK OF ELECTRIC SHOCK. CHECK WITH A QUALIFIED ELECTRICIAN OR SERVICEMAN IF YOU ARE IN DOUBT AS TO WHETHER THE PRODUCT IS PROPERLY GROUNDED.

For a permanently connected product

This product must be connected to a grounded, metal, permanent wiring system, or an equipment-grounding conductor must be run with the circuit conductors and connected to the equipment grounding terminal or lead on the product.

REFERENCE THE QR CODE ON THE EV PEDESTAL FOR LATEST DOCUMENTATION AS THE INFORMATION CONTAINED IN THIS MANUAL IS SUBJECT TO CHANGE.

This product must be installed in accordance with the National Electrical Code® (NEC®) and any applicable local codes. Before installing equipment, check with your local electrical inspector for requirements and information. If you have questions or need assistance, contact a qualified electrical contractor.

SAVE THESE INSTRUCTIONS.

Definitions

EVSE—Electric Vehicle Supply Equipment. EVSE is a general term used for all of the equipment used to supply electricity to the car.

ADA—Americans with Disabilities Act.

UL—Underwriters Laboratories. UL is an accredited standards developer in the U.S. and Canada.

Moving, transporting, and storage instructions

Store the equipment indoors and in its original packaging until it is ready to be installed. Storage temperature should be between -40°C and $+60^{\circ}\text{C}$. Never attempt to lift, move, or carry the equipment by the EV connector cord or power cord. Improper storage or handling may cause damage to the equipment.

| ⚠ WARNING |
|---|
| ONLY QUALIFIED PERSONNEL FAMILIAR WITH THE OPERATION AND CONSTRUCTION OF THIS EQUIPMENT SHOULD INSTALL, ADJUST, MODIFY, AND SERVICE THIS EQUIPMENT. FAILURE TO FOLLOW THE INSTRUCTIONS COULD RESULT IN SEVERE BODILY INJURY OR DEATH. |

| NOTICE |
|--|
| THE USER IS RESPONSIBLE FOR CONFORMING TO ALL LOCAL AND NATIONAL ELECTRICAL CODES AND STANDARDS APPLICABLE IN THE JURISDICTION IN WHICH THIS EQUIPMENT IS INSTALLED. |

NEC Article 625 requires that the coupling means of the electric vehicle supply equipment shall be stored or located at a height of not less than 18 inches (450 mm) and not more than 4 ft (1.2 m) above the floor level for indoor locations and 24 inches (600 mm) above the grade level for outdoor locations.

Americans with Disabilities Act requirements to consider for workplace charging installation

The ADA and workplace charging

The Americans with Disabilities Act (ADA) is a federal civil rights law that prohibits discrimination in public places against individuals with disabilities. As an employer installing plug-in electric vehicle (PEV) charging stations, also known as electric vehicle supply equipment (EVSE), you need to follow special design guidelines to accommodate people with disabilities, as required by the ADA. Although the ADA does not provide design standards for charging station-equipped parking spots, several industry studies and PEV planning guides do. In addition, several plans developed under the U.S. Department of Energy's (DOE) Clean Cities EV Community Readiness projects describe best practices for installing ADA-compliant charging stations.

Best practices for designing ADA-compliant PEV charging stations

When designing ADA-compliant PEV charging stations, consider accessibility, ease of use, and safety for disabled drivers, including those using wheelchairs or other assistive equipment. Key considerations include ensuring adequate space for exiting and entering the vehicle, unobstructed access to the EVSE, free movement around the EVSE and connection point on the vehicle, as well as clear paths and close proximity to any building entrances.

For information about the ADA, including the revised 2010 ADA regulations, please visit the Department's website: <http://www.ada.gov>; or, for answers to specific questions, call the toll-free ADA information line at 800-514-0301 (voice) or 800-514-0383 (TTY).

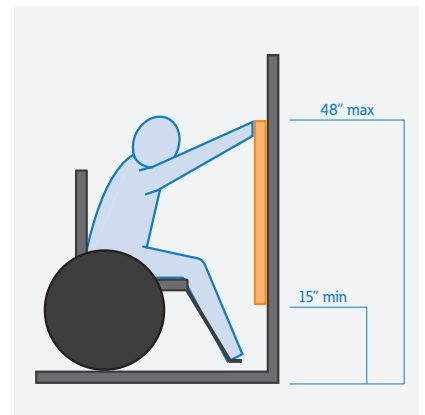
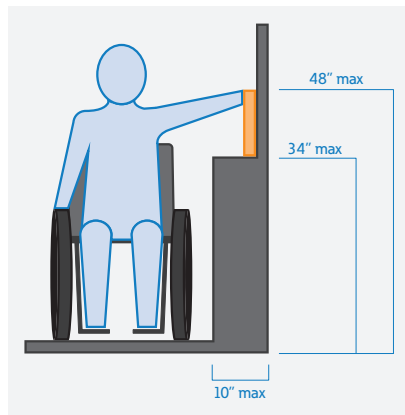
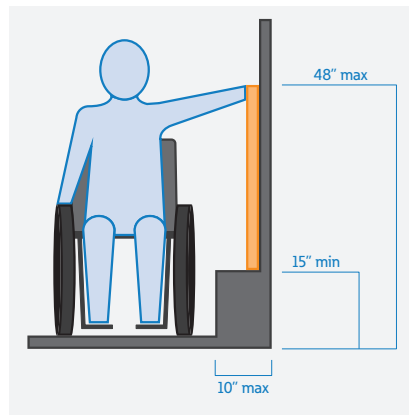

A

EV SINGLE PORT AND DUAL PORT PEDESTAL INSTALLATION

Pour concrete pad and install anchors

WARNINGS AND CAUTIONS

To avoid fire, shock, or death; turn off power at circuit breaker or fuse and test that power is off before wiring.

Read the instructions completely. Failure to follow installation instructions may result in property damage, injury, or death.

- If you have questions about the installation, contact your service representative. Do not attempt to perform a procedure you are unsure of.
- The EV pedestal must be wired per the National Electrical Code (NEC) and local codes.
- The EV wall charger and electrical wiring should be installed by an electrician in accordance with local electrical codes and regulations.
- The EV wall charger is to be connected to a grounded, metal, permanent wiring system. The EV pedestal is to be connected to a ground conductor run from the grounding stud at the bottom of the EV pedestal.
- To ensure that the EV wall charger and EV pedestal are installed per Americans with Disabilities Act (ADA) standards for accessible design guidelines, refer to Code of Federal Regulations document 28 CFR part 36, Sections 4.2 and 4.4
- All local building codes must be adhered to when locating, preparing, installing, and wiring the EV pedestal.
- Installer: Ensure these instructions are left with the user.
- User: Ensure these instructions are kept for future reference.

The following are minimum requirements for preparing the concrete pad and installing the the EV pedestal. Note that local building codes and applicable guidelines should be adhered to for determining the proper location, dimensions, and composition of the concrete pad.

STEP A-1

- Pour concrete pad, being sure to follow all local building codes and best workman practices. Note the following requirements for the pad:
 - » The concrete pad shall be 18 inches by 18 inches minimum
 - » The concrete pad shall be 24 inches deep minimum
- Install three 2-inch maximum PVC conduit sections (1). The PVC conduit shall protrude 3 inches minimum above the surface of the concrete pad.

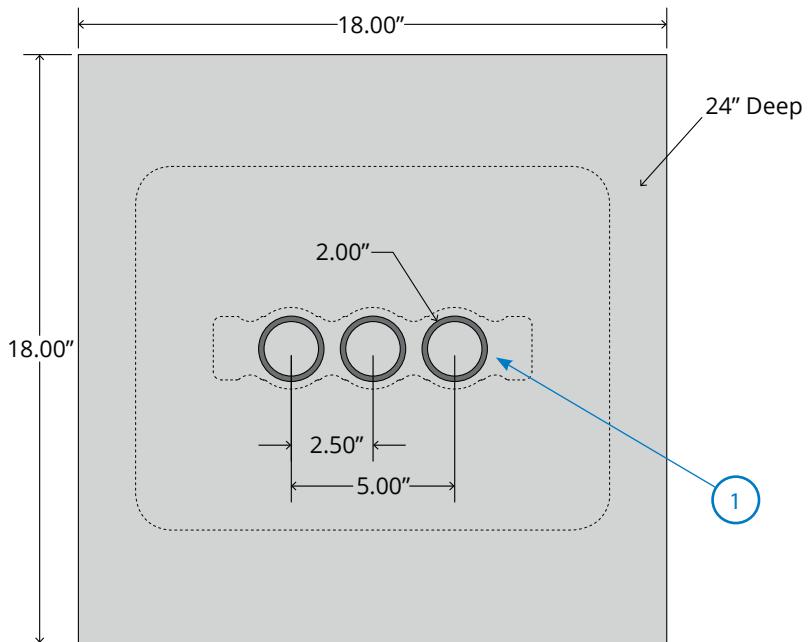

Reference:

- 1. 2-inch maximum PVC conduit sections - x3

Figure 1

A

EV SINGLE PORT AND DUAL PORT PEDESTAL INSTALLATION

Pour concrete pad and install anchors

Note that 3/8-16 stainless steel anchor bolts, L or J type, with a minimum overall length of 8 inches and a minimum threaded length of 2.5 inches, can be installed in the concrete instead of using Tapcon bolts for the four corner locations. Note the hardware type indicated on each illustration.

STEP A-2

Concrete anchors

- While the concrete is wet, insert four 3/8-16 stainless steel anchor bolts (1) (not included), L or J type, according to the illustrated pattern. The bolts shall have a minimum overall length of 8" and a minimum threaded length of 2.5". At least 2" of the threaded portion of the bolt shall protrude above the surface of the concrete.

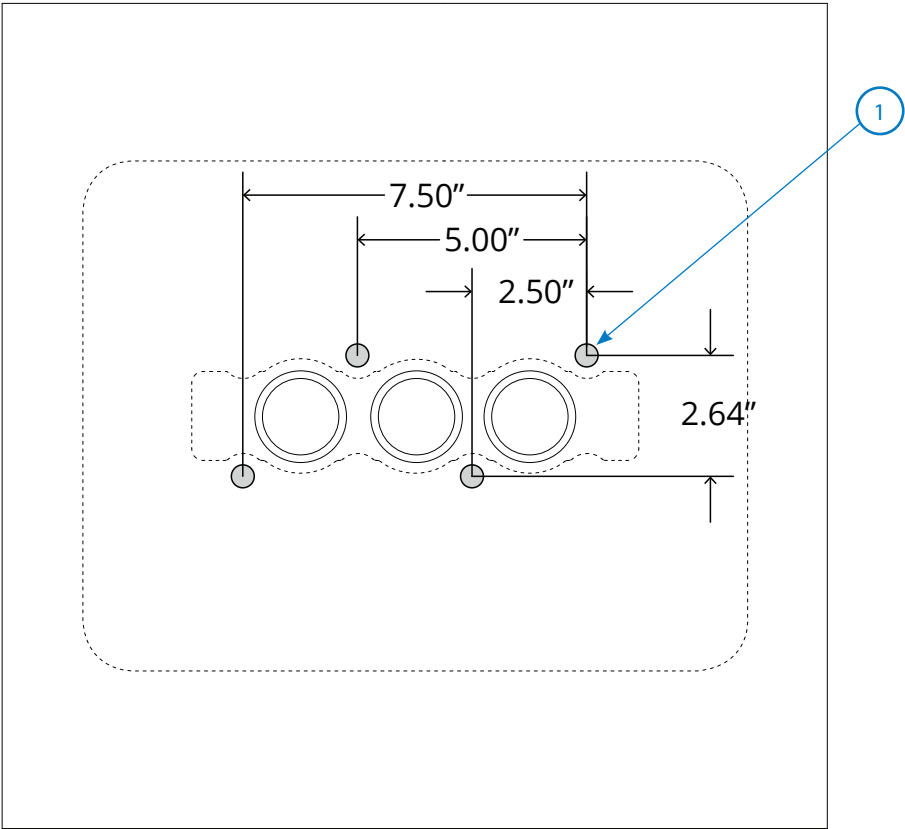

Reference:
1. 3/8-16 stainless steel anchor bolt (not included), L or J type - x4
Figure 2

A

EV SINGLE PORT AND DUAL PORT PEDESTAL INSTALLATION

Pour concrete pad and install anchors

STEP A-2

J type anchors

- While the concrete is wet, insert eight 3/8-16 stainless steel anchor bolts (1) (not included), L or J type, according to the illustrated pattern. The bolts shall have a minimum overall length of 8" and a minimum threaded length of 2.5". At least 2" of the threaded portion of the bolt shall protrude above the surface of the concrete.

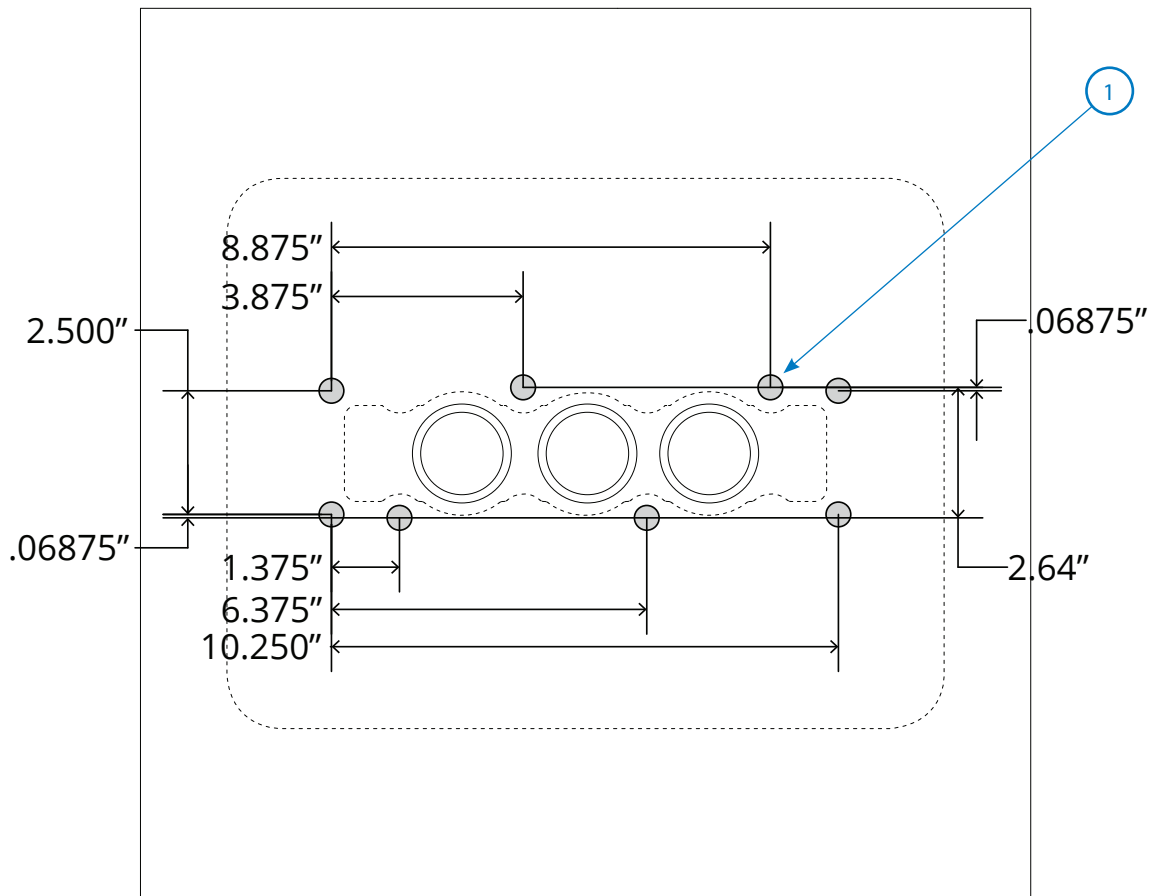

Reference:

1. 3/8-16 stainless steel anchor bolt (not included), L or J type - x8

Figure 3

B

EV SINGLE PORT AND DUAL PORT PEDESTAL INSTALLATION

Install base plate

After the concrete pad preparation has been completed and the concrete has completely set and dried, proceed with the following steps.

| STEP B-1 | Concrete anchors |
|--|------------------|
| <ul style="list-style-type: none"> Place the base plate (1) over the installed anchor bolts. Mark the four corner spaces, remove the base plate, and drill out holes for Tapcon-style concrete anchors (2). The concrete anchors shall be 3/8" diameter. The concrete anchors shall have a minimum lengths of 4". Use 3/8" stainless steel washers (3) when installing the concrete anchors. <p>Reference:</p> <ol style="list-style-type: none"> EV pedestal base plate 3/8-inch diameter Tapcon concrete anchor - x4 3/8 stainless steel washer - x4 <p>Figure 4</p> | |

| STEP B-1 | J type anchors |
|--|----------------|
| <ul style="list-style-type: none"> Place the base plate (1) over the installed anchor bolts. Using 3/8" stainless steel nuts and washers (2), secure the base plate ONLY at the four anchor bolts. <p>Reference:</p> <ol style="list-style-type: none"> EV pedestal base plate 3/8-inch stainless steel nut and washer - x8 <p>Figure 5</p> | |

C

EV SINGLE PORT AND DUAL PORT PEDESTAL INSTALLATION

Remove cover panels

STEP C-1 Concrete & J type anchors

- Retrieve the EV pedestal wrap. Remove the bottom cover panel located on the rear of the unit (1).

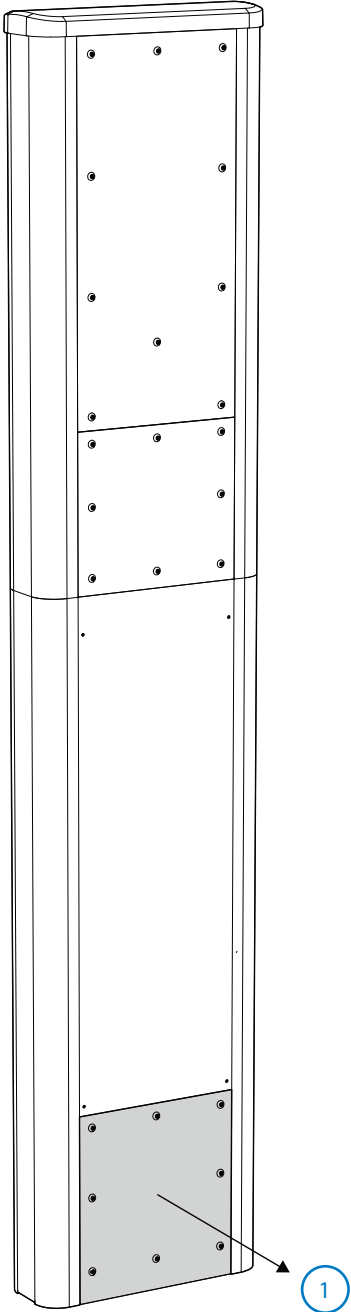

Reference:
1. Bottom cover panel
Figure 6

D

EV SINGLE PORT AND DUAL PORT PEDESTAL INSTALLATION

Install EV pedestal

STEP D-1 Concrete & J type anchors

- Position EV pedestal wrap lower section (1) onto the EV pedestal base plate (2) such that the six 3/8-16 studs and four 3/8-16 anchors protruding from the EV pedestal base plate align with the holes on the EV pedestal wrap lower section.
- Use 10 washers and 3/8-16 nylon locknuts (3) to secure the EV pedestal wrap lower section to the studs (4) protruding from the EV pedestal base plate.

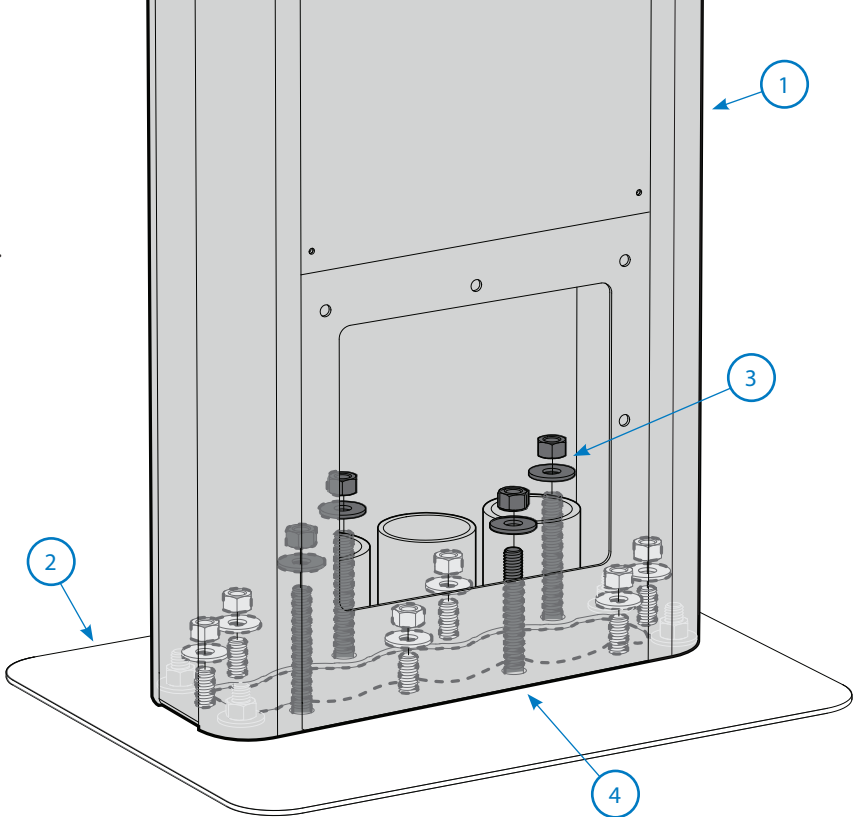

- Reference:
1. EV pedestal wrap lower section
 2. EV pedestal base plate
 3. 3/8-16 hex nut and 3/8 washer - x10
 4. EV pedestal base plate studs - x4

Figure 7

STEP D-2 Concrete & J type anchors

- The EV pedestal wrap lower section (1) has a grounding lug (2) located approximately 3 inches up from the bottom of the EV pedestal. A grounding wire (3) should be run from a ground rod and terminated on the grounding lug. All applicable local building codes and electrical codes should be followed.

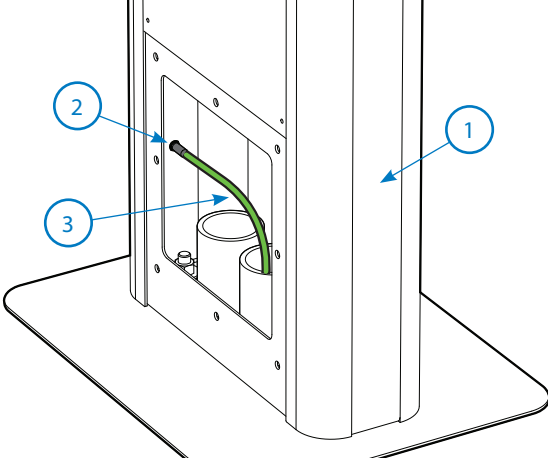

- Reference:
1. EV pedestal wrap lower section
 2. Grounding lug
 3. Grounding wire

Figure 8

To continue, refer to the installation guide included with your EV charger. If you are not ready to install an EV wall charger at this time, please proceed to Step E-1 to re-attach the cover panel.

E

EV SINGLE PORT AND DUAL PORT PEDESTAL INSTALLATION

Replace cover plates

STEP E-1 Concrete & J type anchors

- Replace cover plate

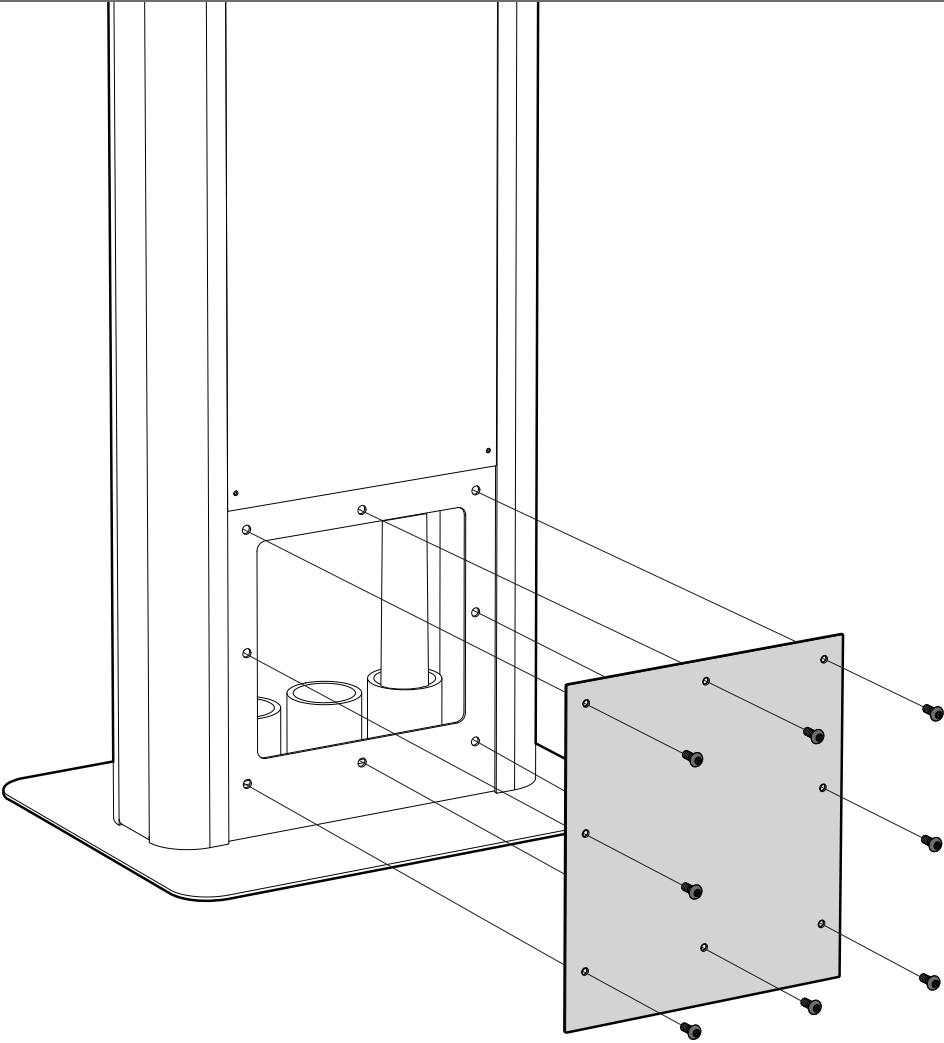

Figure 9

Technical specifications

| Description | Specification |
|----------------|--|
| Catalog number | GMEV-PED, GMEV-DPED |
| Installation | EV wall chargers hard wired through pedestal |
| Warranty | <p>Seller warrants that the Products manufactured by it will conform to Seller's applicable specifications and be free from failure due to defects in workmanship and material for three (3) years from the date of original purchase, installation of the Product, or from the date of shipment of the Product, whichever occurs first. In the event any Product fails to comply with the foregoing warranty, Seller will, at its option, either (a) repair or replace the defective Product, or defective part or component thereof, F.O.B. Seller's facility freight prepaid, or (b) credit Buyer for the purchase price of the Product. All warranty claims shall be made in writing. Seller requires all non-conforming Products be returned at Seller's expense for reevaluation unless specifically stated otherwise in writing by Seller. This warranty does not cover failure or damage due to storage, installation, operation or maintenance not in conformance with Seller's recommendations, including asset for theft in these Terms and Conditions of Sale, and industry standard practice or due to accident, misuse, abuse, or negligence. This warranty does not cover breach of data or system security, including that of information technology infrastructure, computers, software, hardware, databases, electronics systems (including database management systems), and networks. This warranty does not cover reimbursement for labor, gaining access, removal, installation, temporary power or any other expenses, which may be incurred in connection with repair or replacement. This warranty does not apply to equipment not manufactured by Seller. Seller limits itself to extending the same warranty it receives from the third-party supplier, to the extent such third party permits assignment of its warranty. For other general terms and conditions of sale, please refer to Eaton's selling policy 25-000.</p> |
| Certifications | UL 1773 - Mounting Posts and Pedestals for Distribution Equipment |



Eaton
1000 Eaton Boulevard
Cleveland, OH 44122
United States
Eaton.com

© 2022 Eaton
All Rights Reserved
Printed in USA
Publication No. IL191010EN
August 2022

Eaton is a registered trademark.

All trademarks are property
of their respective owners.