

Digital Proportional Power Plug

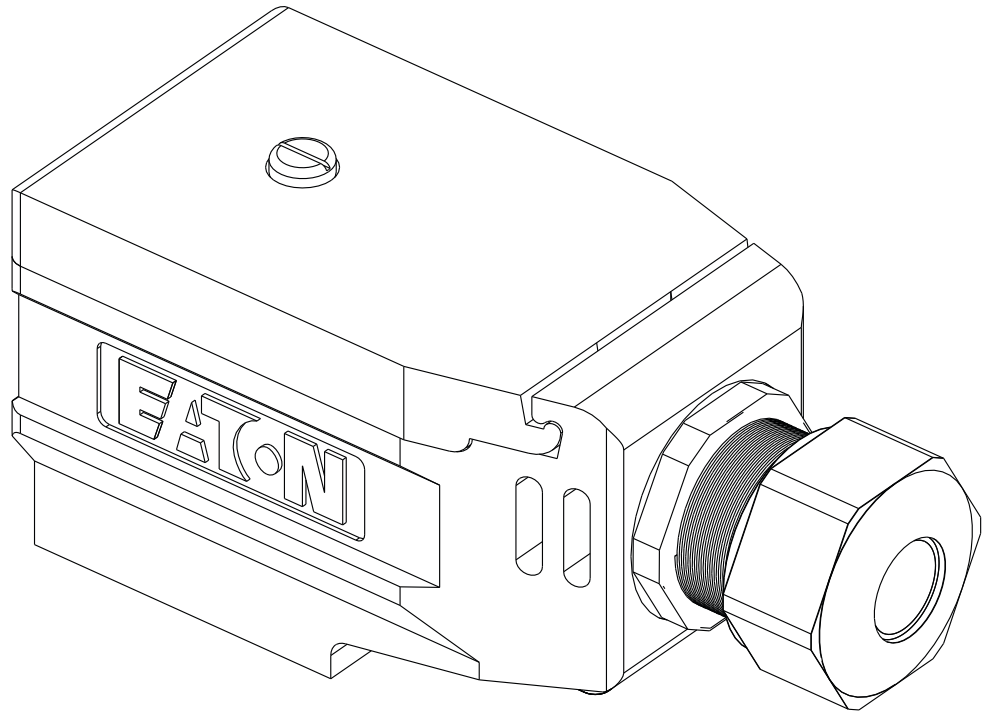

Installation and startup guideline for Digital Power Plug for proportional valves

EHH-AMP-702-D/C/K-R-P-1-30
EHH-AMP-712-D/G-R-P-1-30
EHH-AMP-702/712-N-C-N-3-30
EHH-AMP-702-D-R-P-2-30
EHH-AMP-702/712-P-R-P-1-30
EHH-AMP-702-N-S-N-4-30
EU3E-SWD-X1H-1



Article No:
6024153-XXX
6035904-001

EATON

Powering Business Worldwide

Introduction

All plugs except the EHH-AMP-702-N-S-N-4-30 and the EU3E-SWD-X1H-1 are suitable with the following Eaton products, when fitted with the appropriate coil: KD/TG4V-3(S), KD/TG4V-5, KCG-3/6/8, KX(C)G-6/8, KDG5V-5/7/8, CMX, EPV, ERV1/2, EPFR1. The EHH-AMP-702-N-S-N-4-30 and the EU3E-SWD-X1H-1 are suitable with the following Eaton products when fitted with the appropriate coil: KDG4V-3(S), KDG4V-5, KTG4V-3(S), KTG4V-5, KCG-3/6/8, KX(C)-6/8, KDG5V-5/7/8.

The operation of this plug has been factory checked before dispatch.

The plug is ready for use as supplied, but it must be properly installed by a qualified person using the machine designer's wiring diagrams.

Pre installation checks

1. Check for any damage received in transit.
2. Ensure that the model code on this plug is correct one for the application.
3. Check that the DC power supply is within the specification for the plug.
20-30VDC including $\pm 10\%$ peak to peak ripple for EHH-AMP-702
10-16VDC including $\pm 10\%$ peak to peak ripple for EHH-AMP-71
20.4-28.8 VDC including -15%/+20% peak to peak ripple for EHH-AMP-702-N-S-N-4-30 (SmartWire-DT.)
4. Ensure that the power is switched OFF before installing it on to the valve. (Never fit or remove the amplifier while the power is switched ON).

- B.** For EHH-AMP-702-D-R-P-2-30
EHH-AMP-702/712-P-R-P-1-30
EHH-AMP-702-D/C/K-R-P-1-30
EHH-AMP-712-D-R-P-1-30 and
EHH-AMP-712-G-R-P-1-30 with internal 5V reference for joystick

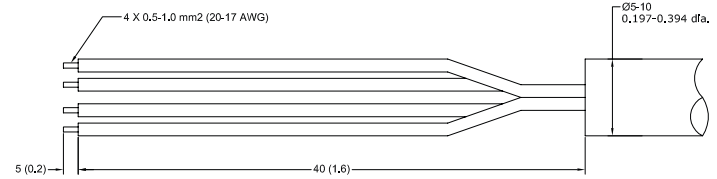

Figure 2

- C.** EHH-AMP-702/712-N-C-N-3-30

M12-5 PIN FEMALE CONNECTOR WITH CABLE

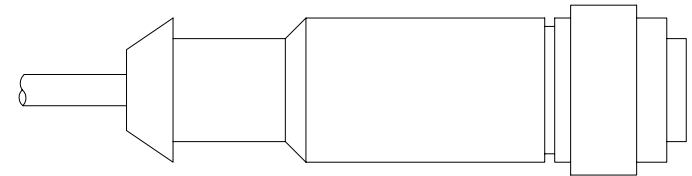

Figure 3

- D.** EHH-AMP-702-N-S-N-4-30/EU3E-SWD-X1H-1
Use Eaton SmartWire-DT round cable SWD4-..LR5-2S to the SWD IN and SWD OUT connectors.

Wiring preparation

- A.** For EHH-AMP-712-G-R-P-1-30 for external 5V command with Common supply ground

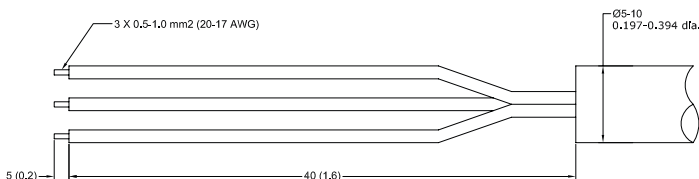

Figure 1



This product has been designed and tested to meet specific standards outlined in the European Electromagnetic Compatibility Directive (EMC) 89/336/EEC, amended by 91/263/EEC, 92/31/EEC and 93/68/EEC, article 5. For instructions on installation requirements to achieve effective protection levels, see this leaflet and the Installation Wiring Practices for Vickers Electronic Products leaflet 2468. Wiring practices relevant to this Directive are indicated by Electromagnetic Compatibility (EMC).

Electrical Block Diagrams

EHH-AMP-702/712-D/C/K -R-P-1/2-30

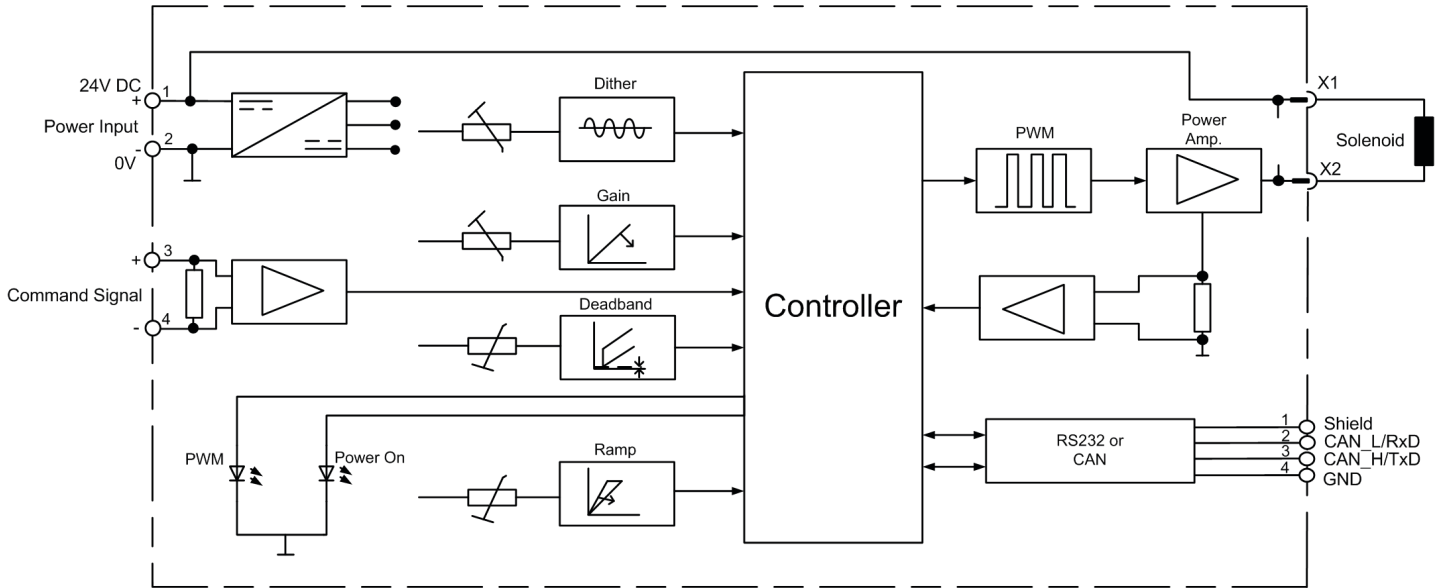

Figure 4

EHH-AMP-702/712-P-R-P-1-30

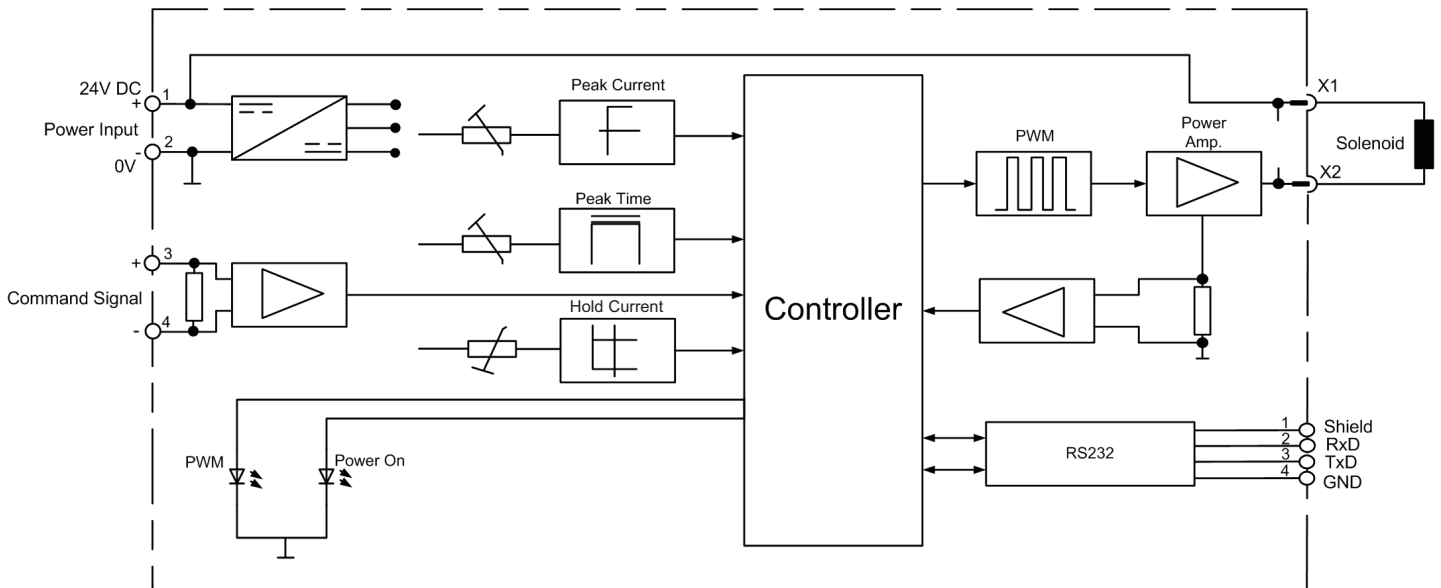
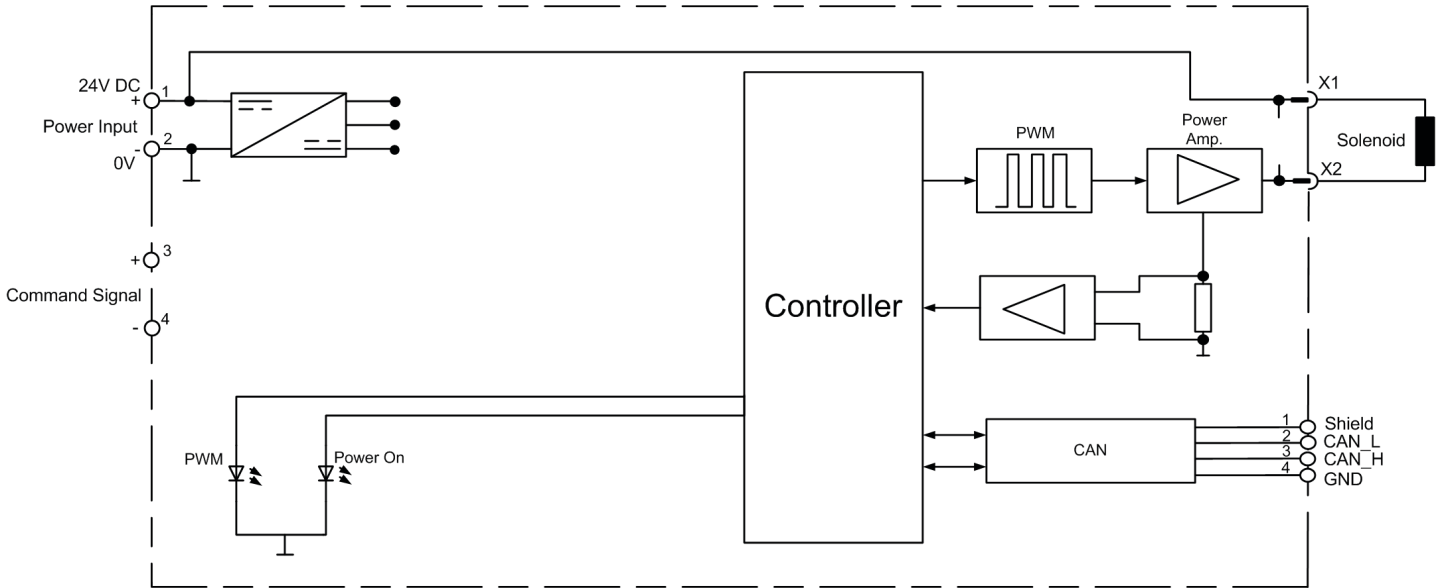

Figure 5

Electrical Block Diagrams

EHH-AMP-702/712-N-C-N-3-30



*Command and Setting parameter are through CAN communication

Figure 6

EHH-AMP-712-G-R-P-1/2-30

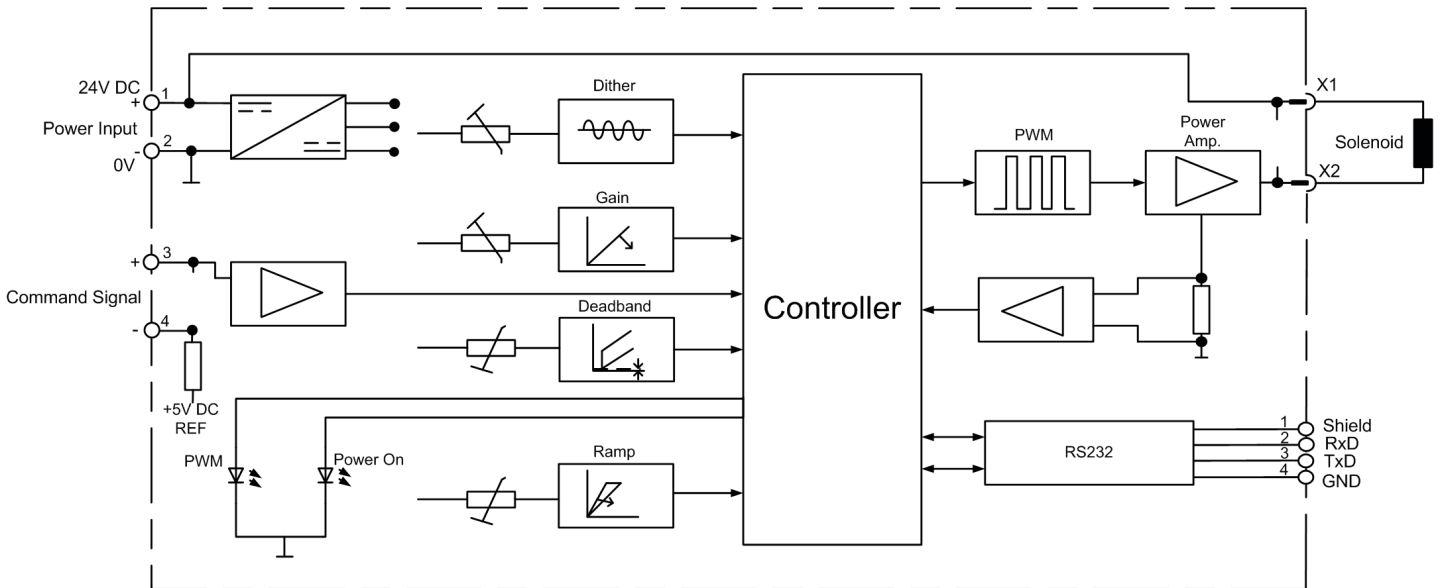
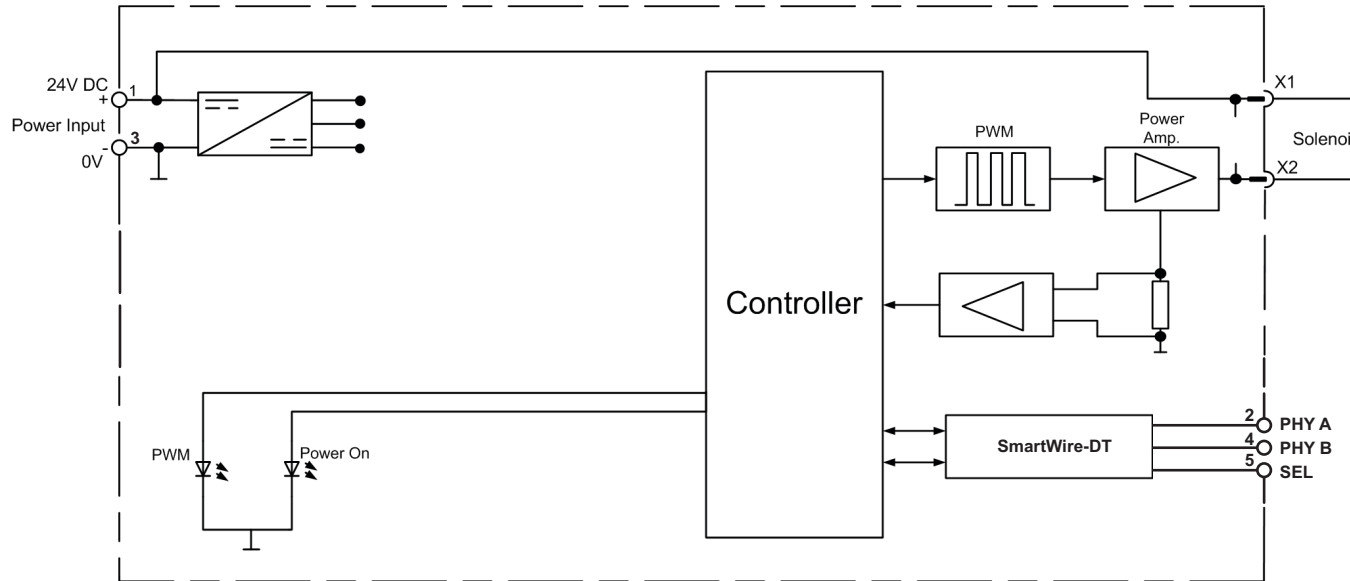

Figure 7

Electrical Block Diagrams

EHH-AMP-702-N-S-N-4-30



*Command and Setting parameter are through CAN communication

Figure 8

Installation Wiring Options

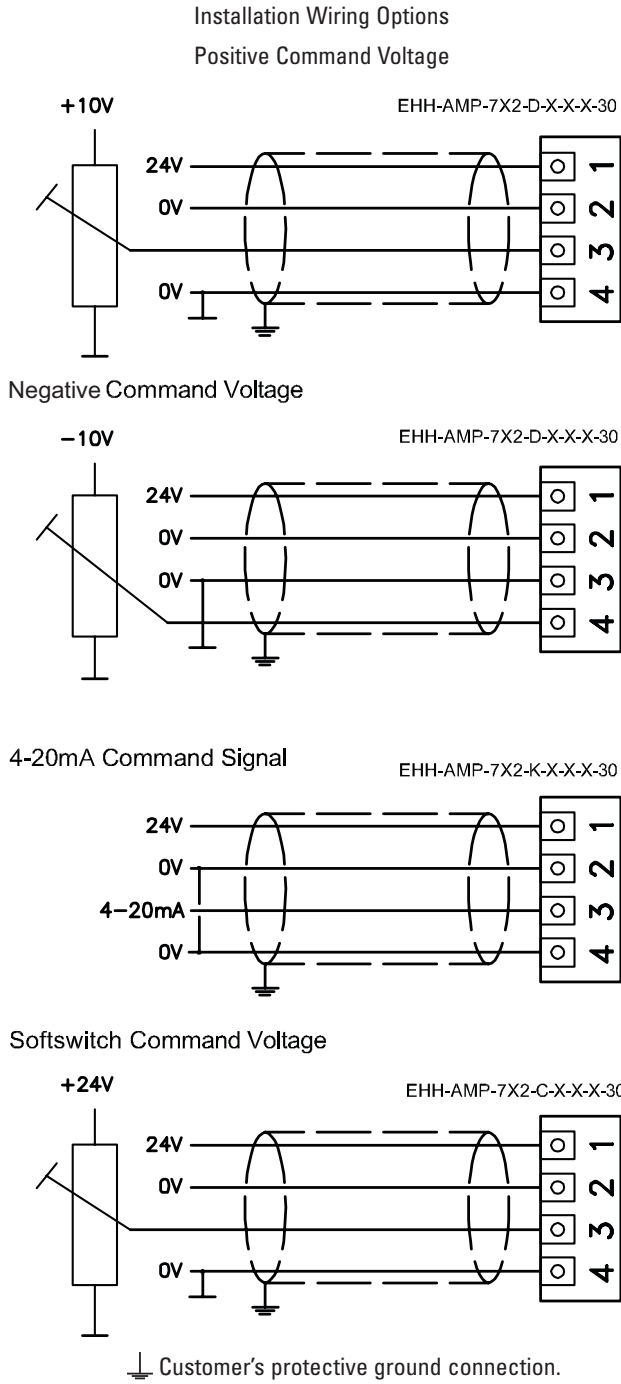

Figure 9



Warning: Electromagnetic Compatibility (EMC)

Screened cables should be used and particular attention paid to the grounding of the screens as shown in the above diagrams.

Bi-polar Command Voltage for Operating
Two Solenoids for One Signal

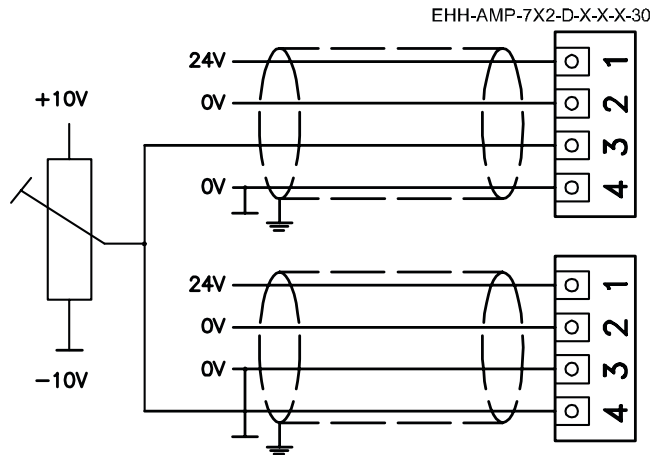

Internal 5V Command Signal

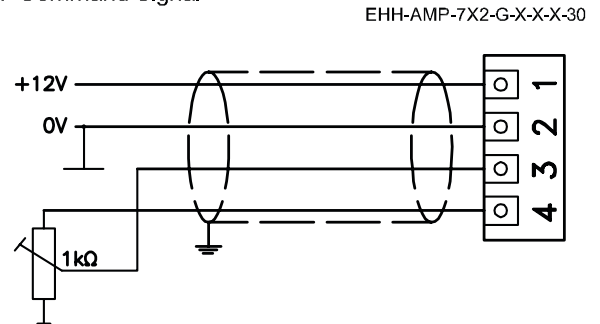

External 5V Command Signal

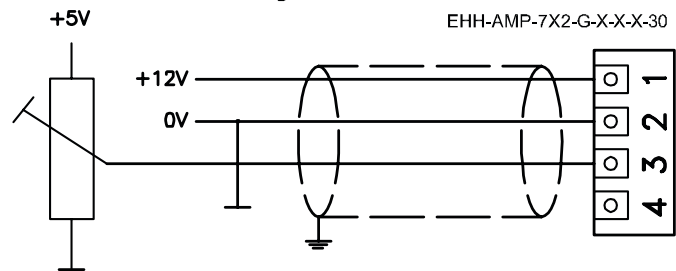

Note: For EHH-AMP-7X2-N-C-N-3-30 wiring diagram please refer the connection diagram for the same

Installation Wiring Options

Standard CAN (EHH-AMP-702/712-N-C-N-30)

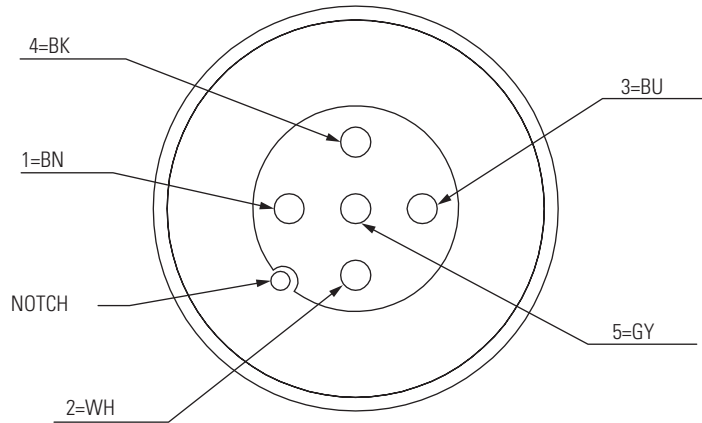

SmartWire-DT (EHH-AMP-702-N-S-N-4-30, EU3E-SWD-X1H-1)

| Pin number | Color | Description |
|------------|---------------|--|
| 1 | Brown | 24 V supply voltage for smartWire-DT modules + sensors/actuators |
| 2 | White | Data cable A |
| 3 | Blue | 0 V |
| 4 | Black | Data cable B |
| 5 | Yellow/ Green | Select cable for automatic addressing of the SWD slaves |

Connector Pinout

| Pin number | Description |
|------------|-----------------|
| 1 | CAN Shield |
| 2 | Supply Positive |
| 3 | Supply GND |
| 4 | CAN H |
| 5 | CAN L |

Figure 10

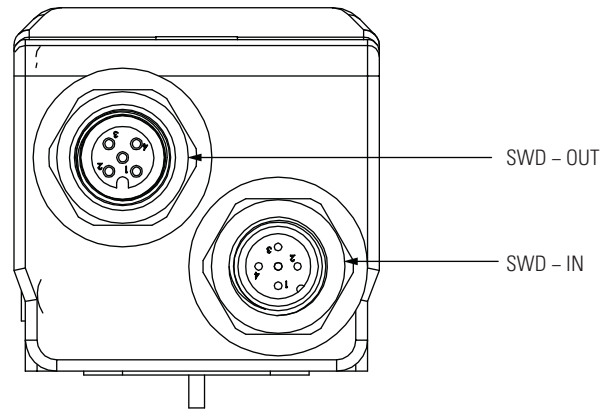

EHH-AMP-7X2-D/C/K/G/P-R-P-X-30 Connectors pin out

| Connector | Pin number | Description |
|--------------------------------------|------------|--|
| Supply connector | 1 | Supply positive |
| | 2 | Supply GND |
| | 3 | Command + (For G type - Joystick I/P) |
| | 4 | Command - (For G type - +5V reference) |
| RS232 serial communication connector | 1 | NC |
| | 2 | RXD |
| | 3 | TXD |
| | 4 | GND |

Supply connector is wire to board connector. Mating part for communication connector is MOLEX / WALDOM 51021-0400 (See Figure 11).

Adjustment

EHH-AMP-702/712-D/G/C/K-R-P-1/2-30

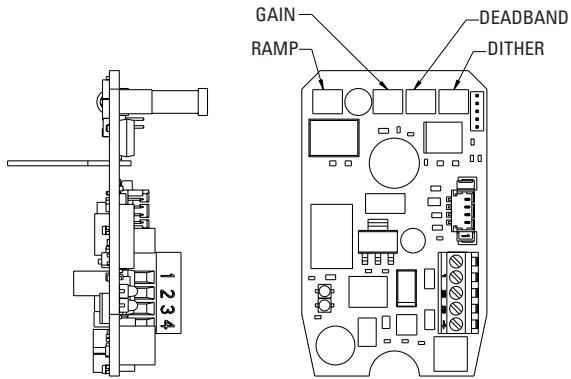

Turn clockwise to increase the value of parameter.

Figure 11

EHH-AMP-702/712-P-R-P-1-30

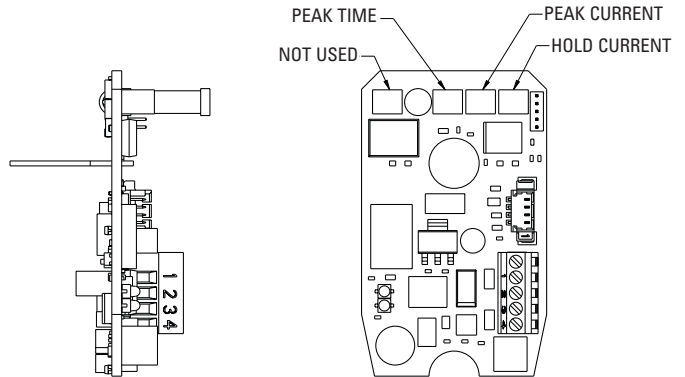

EHH-AMP-702/712-D/C/K-R-P-1/2-30

Connection diagram for RS232 Versions (EHH-AMP-7XX-)

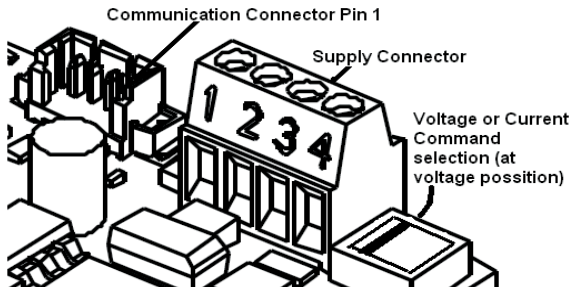

Figure 12

RS232 Serial Communication connector, Supply connector and Voltage/Current switch location

The Switch position shown in the diagram is for Voltage or Soft Switch command. Change the switch position to right for current command.

Note: Switch is preset depending on the model code selected.

Assemblies

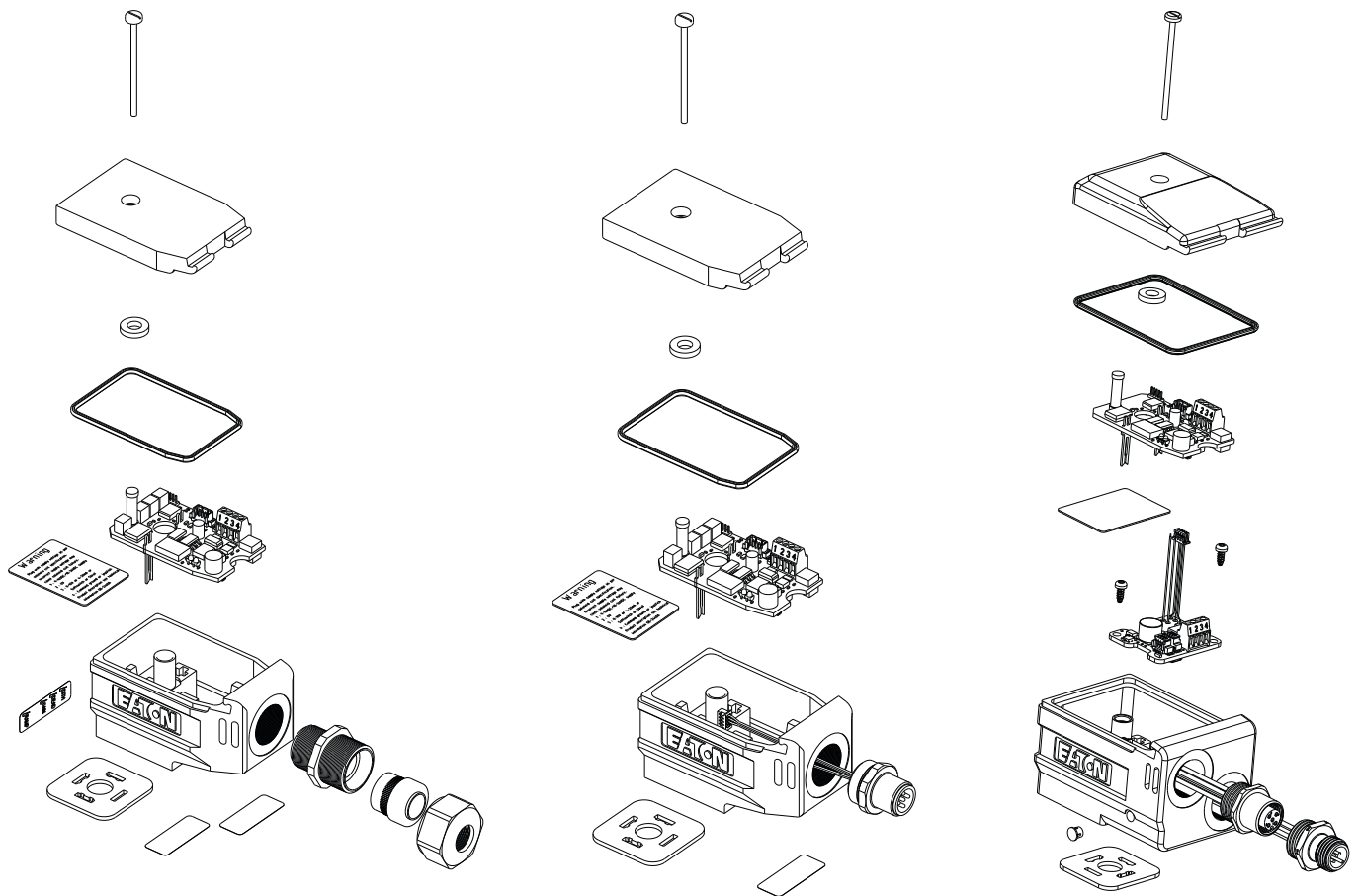

Warning:

- Ensure cable clamp nut is adequately tightened to secure the cable.
- Do not connect, or disconnect, the plug while power is on.
- Do not mount, or dismount, the plug while power is on.

Start-up

1. With the plug correctly wired but not mounted to the load provide with a DC power supply (See table).

| Power Plug type | 702-D-R-P | 702-C-R-P | 702-K-R-P | 712-G-R-P | 712-D-R-P | 702-N-C-N | 702-D-R-P | 712-N-C-N | 712-P-R-P | 702-P-R-P |
|----------------------|-----------|-----------|-----------|------------|------------|-----------|-----------|------------|------------|-----------|
| Supply/Signal | | | | | | | | | | |
| DC Power Supply | 20 – 30V | 20 – 30V | 20 – 30V | 10.2 – 16V | 10.2 – 16V | 20 – 30V | 20 – 30V | 10.2 – 16V | 10.2 – 16V | 20 – 30V |
| Command signal (ON) | 0.2 – 10V | 11 – 24V | 4-20mA | 0.2 – 5V | 0.2 – 10V | Software | 0.2 – 10V | Software | 0.2 – 10V | 0.2 – 10V |
| Command Signal (OFF) | <0.1V | <5V | <4mA | <0.1V | <0.1V | Software | <0.1V | Software | <0.1V | <0.1V |

2. Apply the command signal (ON) and check the Power ON LED (RED) illuminates. Reduce the signal to the Command signal (OFF) level and check the LED (RED) goes out.
3. If there is malfunction to the LED replace the plug.
4. Switch off the power supply and command signal and connect the plug to the load. Ensure that the interface seal is correctly fitted and clamped between the mounting faces (essential for IP65 protection). Tighten the retaining screw.
5. Ensure that no damage or injury will occur on the machine when the valve is operated.
6. Switch on the power supply. Apply the command signal.
 - (a) Observe Power On LED (RED) is ON.
 - (b) Observe PWM LED (Orange) is ON.
 If LED is not operated then there is short circuit in the load. Replace the load/load coil.
7. Successful completion of these steps means that the plug and load are ready for normal use

Note: The Graphical User Interface software's executable files (part number: 6024157-001) for RS232 and CAN interface (With ValueCAN adaptor) with PC can be used to check, operate and set the parameters like RAMP, GAIN, DEADBAND and DITHER for the plug. For more detail information please refer GUI help menu.

Data rate for communication:

For CAN bus communication, the standard baud rate is 125Kbit. Default address is ID=1.

For RS232 communication, the standard baud rate is 9600bps, 8bit data, No Parity, 1stop bit.

Schematic for a M12 (female) to SubD9 (female) CAN bus Interface:

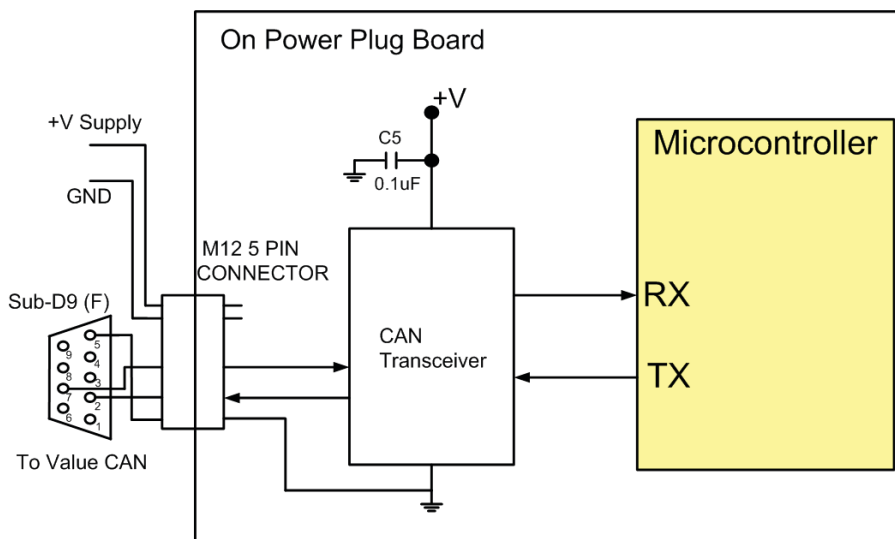

There is no bus termination resistor on the power plug board internally.

Start-up

| M12 Female connector pin no | Subd9 Female (For ValueCAN) connector pin no |
|-----------------------------|---|
| 1 | Pin 5 (Optional) |
| 2 | Not connected to this connector (For Supply Positive) |
| 3 | Not connected to this connector (For Supply Ground) |
| 4 | 7 (CAN H) |
| 5 | 2 (CAN L) |

Schematic for the RS232 communication, with Molex connector to SubD9 female interface:

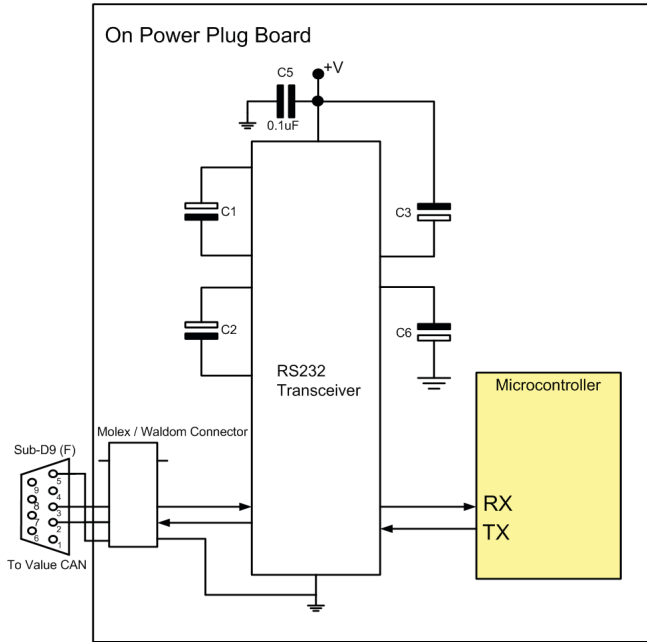

| Molex/Waldom 51021-0400 Female connector pin no | Subd9 Female (For Computer) connector pin no |
|---|--|
| 1 (NC) | |
| 2 (RxD) | 3 (TxD) |
| 3 (TxD) | 2 (RxD) |
| 4 (GND) | 5 (GND) |

EHH-AMP-702 N-S-N-4-30/EU3E-SWD-X1H-1 SmartWire-DT Startup.

This module requires commissioning using the SWD-Assist software. This software can be downloaded at <http://www.eaton.com/>.

For more information on this SmartWire-DT module as well as for general information on SmartWire-DT, please refer to the following manual:

“SmartWire-DT The system” - MN05006002Z-EN

This document can be downloaded in the form of a PDF file at <http://www.eaton.com/>.

Spare Parts

The only part available is the interface seal, part number 732 100.

Eaton
Hydraulics Group USA
14615 Lone Oak Road
Eden Prairie, MN 55344
USA
Tel: 952-937-9800
Fax: 952-294-7722
www.eaton.com/hydraulics

Eaton
Hydraulics Group Europe
Route de la Longeraie 7
1110 Morges
Switzerland
Tel: +41 (0) 21 811 4600
Fax: +41 (0) 21 811 4601

Eaton
Hydraulics Group Asia Pacific
Eaton Building
No.7 Lane 280 Linhong Road
Changning District,
Shanghai 200335
China
Tel: (+86 21) 5200 0099
Fax: (+86 21) 2230 7240