

# Din Rail Module Amplifier for Proportional Valves



## Introduction

Din Rail module amplifier is a cabinet mount electronic that will drive two solenoids to position the spool of open or closed loop valve or pump. It has a CANOpen and RS232 communication for command, feedback, status parameter setup. Feedback sensors like Hall effect sensor (0- 5 V), LVDT sensor (4-20 mA), or external sensor (4-20 mA) can be connected to the amplifier. The valve can be calibrated through the graphical user interface (GUI) provided by EATON which has the connectivity with computer through CANopen.

## EHH-PAM-600-A-10

E	electronics amplifier
H	with housing
H	hybrid (digital and analog) electronics
PAM	power amplifier
600	for the generic version
601	to 699 for specific versions for specific valves (613 / 671...)
A	standard version
10	design number, first design

## Application

Primary applications are in the control of directly operated, non-feedback/ feedback proportional valves where the cost of more complex electronic controls can be avoided.

To be used with the following valves:  
KDG\*, KCG\*, EPRV\*, EPV\*

## Features and Benefits

- Integral amplifier provides essential functions for control of proportional valves
- Configuration of the valve through CANopen and serial communication
- Adjustable ramp time, gain, dead band, dither compensation through CANopen communication
- Ease of installation, with reduced cost
- Fully short-circuit and reverse-polarity protected
- Differential voltage command signal.
- EMC to latest European standards
- 12V or 24V operation



*Powering Business Worldwide*

# Electrical Block Diagram:

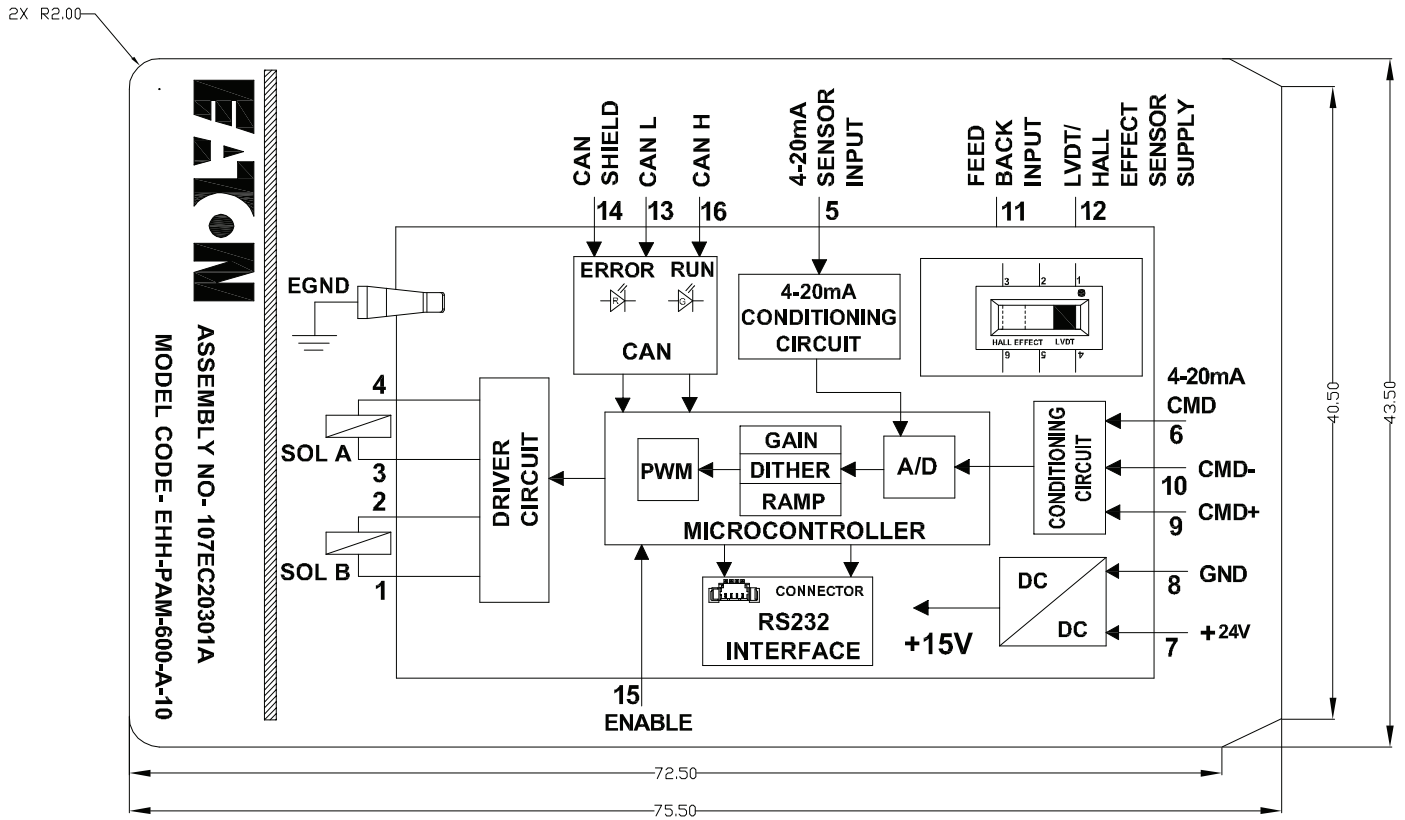

## Connection diagram

Pin Number	Description
1	SOLB+
2	SOLB-
3	SOLA+
4	SOLA-
5	4-20mA Sensor Input
6	4-20mA current command
7	+24V/+12V
8	GND
9	COM+
10	COM-
11	FB_INPUT
12	LVDT Supply
13	CAN_L
14	CAN_SHIELD
15	Enable
16	CAN_H

# Operating Data:

## Electrical:

Description	Limits	
Connections	See the connection diagrams above	
Power (input) Supply	9 to 16Vdc (+/- 10 %) for 12V nominal	18 to 36Vdc (+/- 10 %)for 24V nominal
Reverse polarity protected	Yes	
Short circuit protected	Yes	
Maximum output current	3A for 12V supply	3A for 24V supply
Max. output voltage typical (3.5A output current)	Typically 1.5V below supply voltage	
Command signal	Voltage Command (+/-10V) (+/- 10 %) Current Command (4 to 20mA) (+/- 10 %) CAN Command (Digital Command 0 to +/-16384) Command via RS232 ( digital command 0 to +/-1000)	
Dead band triggering	0.2 V to 10 V	12.2 mA to 20 mA
For output	-0.2 V to -10V	11.8 mA to 4 mA
For no output	-0.2 V to 0.2 V	11.8 mA to 12.2mA
Dead band adjustment range	0 to 16384 Count ( 0 to 3 A) (+/- 5 %)	
Gain adjustment range	0 to 16384 count (+/- 5 %) For Current control (0 to 100 %) For Single stage Control (0 to 145%)	
Dither adjustment range	0 to 3000 Count (0 to . 1.2 A) (+/-10 %)	
Ramp time	0 to 9 seconds +/- 10 %)	
PWM frequency	1200 Hz _(+/-10%)	
Dither frequency	120 Hz _(+/-10%)	
Protection	Fully short-circuit and reverse-polarity protected	
Communication	RS232 – 19200 Kbps for 50 meters	CAN – Baud rate supported 20K, 50K, 125K, 250K, 500K, 800K and 1000K. Supported profile: DS408 state machine.

## Mechanical:

Description	Limits
Housing	Phoenix ME 22.5 Connector pins: 16 Max. current: 4A Max. voltage: 250V
Temperature, ambient range	-20°C to +70°C
Mass	0,118 kg (0.260 lbs.)

# Serial Connector Placement on Amplifier PCB:

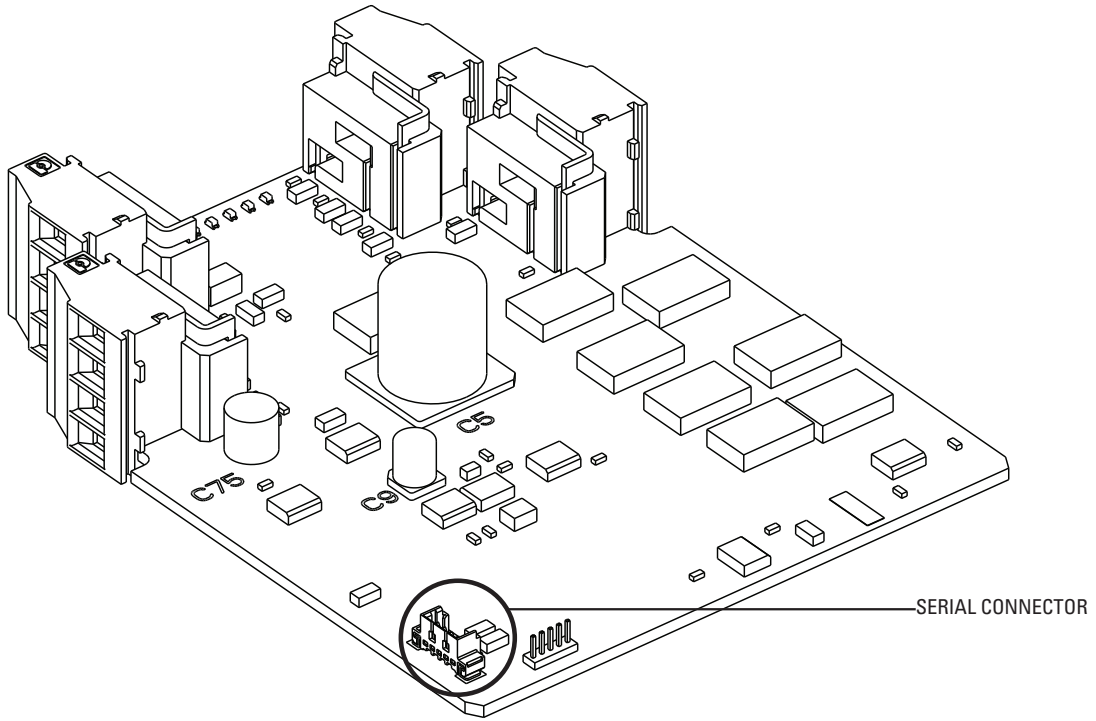

## Installation Dimensions in mm:

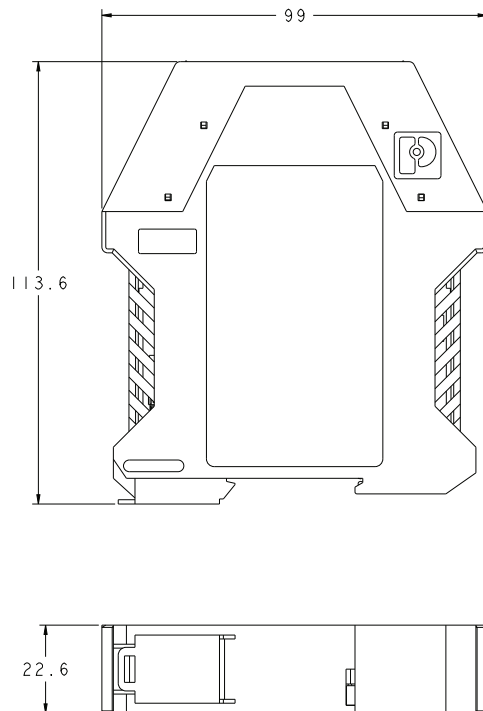

## Wiring Diagrams:

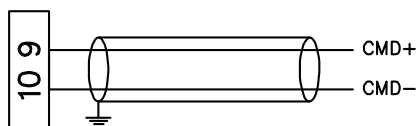
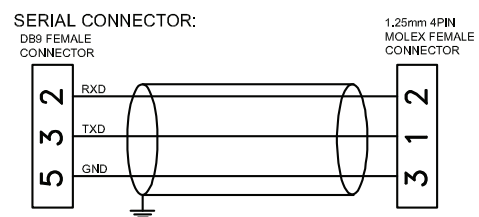
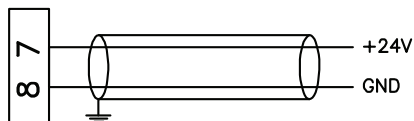
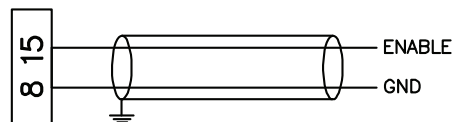
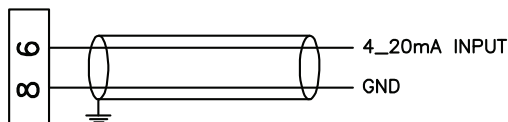
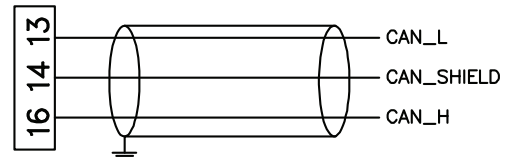
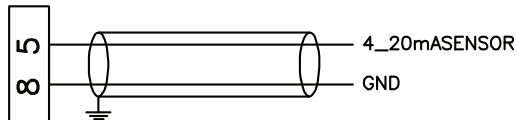
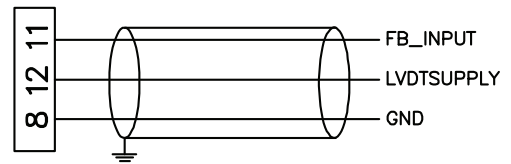
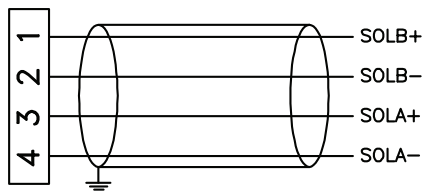

⏚ CUSTOMER'S PROACTIVE GROUND CONNECTION

## Start-Up Procedure:

- Correctly wire the amplifier before mounting it with the valve solenoid. Apply supply voltage to the "power input" terminals.
- Check for correct amplifier function by illumination/non-illumination of the LEDs. The RUN LED (green) should illuminate when the correct supply is given. The +VE CMD/-VE CMD (green) should illuminate when demand applied to the "signal input" terminal is correct and within limit. If there is a malfunction, a new amplifier must be fitted.
- Switch off power supply and command/input signal and then install amplifier with solenoid. Ensure that all connections are fitted correctly.
- Ensure that the hydraulic system will not cause any erratic movement of actuators, then:
- Switch on power supply again. Repeat LED/function check.
- Successful completion of these checks means that the amplifier and load are ready for use.

# Configuration Software for CANbus:

“Pro-Fx: Configure” is intended to use with Din Rail Module amplifier. It is a PC-based tool used for advanced electronic product set-up, configuration, and diagnostics and troubleshooting over CAN bus.

Installation Guide and Software is available at

[http://www.eaton.com/Eaton/ProductsServices/Hydraulics/ElectronicsSoftware/PCT\\_258653](http://www.eaton.com/Eaton/ProductsServices/Hydraulics/ElectronicsSoftware/PCT_258653)

## Available part numbers:

Model Code :EHH-PAM-600-A-10

Assembly No: 107EC20301A

Eaton  
Hydraulics Group USA  
14615 Lone Oak Road  
Eden Prairie, MN 55344  
USA  
Tel: 952-937-9800  
Fax: 952-294-7722  
[www.eaton.com/hydraulics](http://www.eaton.com/hydraulics)

Eaton  
Hydraulics Group Europe  
Route de la Longeraie 7  
1110 Morges  
Switzerland  
Tel: +41 (0) 21 811 4600  
Fax: +41 (0) 21 811 4601

Eaton  
Hydraulics Group Asia Pacific  
Eaton Building  
4th Floor, No. 3 Lane 280 Linhong Rd.  
Changning District  
Shanghai 200335  
China  
Tel: (+86 21) 5200 0099  
Fax: (+86 21) 5200 0400