

# LTA1V

## 10BASE-T/100BASE-TX Automotive LAN transformer

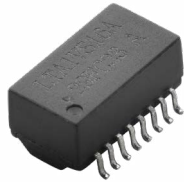

Photo is representative

### Product features

- IEEE 802.3u compliant
- AEC-Q200
- 1500 Vac isolation between primary and secondary
- Single port
- Weight 0.74 g typical
- Moisture sensitivity level (MSL): 1

### Applications

- T-Box
- 10BASE-T/100BASE-TX Interface
- Infotainment
- ADAS
- Battery management systems

### Environmental compliance and general specifications

- Operating ambient temperature range: Single -40 °C to +125 °C
- Storage temperature (component): -40 °C to +125 °C



Product specifications (+25 °C)

Part number <sup>5</sup>	Port	Pins	Inductance <sup>1,6</sup> ( $\mu$ H)	Leakage inductance <sup>2,6</sup> ( $\mu$ H)	DCR <sup>4,6</sup> ( $\Omega$ )	CWW <sup>2,6</sup> (pF)	Turns ratio <sup>3</sup>	Insertion loss <sup>3,6</sup> (dB)	Return loss <sup>3,6</sup> (dB)	Cross talk <sup>6</sup> (dB) (between each channel)	CMRR <sup>3,6</sup> (dB)
LTA1VS16A-351-R	Single	16	350	0.5	1.2	35	1CT:1CT, $\pm 2\%$	-1.1@ 1-100 MHz  -3.0@ 125 MHz	-18 @ 5 MHz  -16+26log(f/30)@ 30-80 MHz	-62 @ 1 MHz  -45+21*log(f/30) @ 5-100 MHz	-50+17log(f/5) @ 5-200MHz
LTA1VS16B-351-R	Single	16	350	0.5	1.2	35	1CT:1CT, $\pm 2\%$	-1.1@ 1-100 MHz	-18@0.5-30 MHz  -18+20log(f/30)@ 30.1-60 MHz -12@ 60.1-80 MHz	-35 @ 0.5-40 MHz  -30 @ 40.1-100 MHz	-30 @ 0.5-100MHz
LTA1VS16C-351-R	Single	16	350	0.5	1.2	35	1CT:1CT, $\pm 2\%$	-1.1@ 0.5-100 MHz	-18@0.5-30 MHz  -18+20log(f/30)@ 30.1-60 MHz -12@ 60.1-80MHz	-35 @ 0.5-40 MHz  -30 @ 40.1-100 MHz	-30@0.5-100MHz

- Inductance (Transformer side): Test parameters: 100 kHz, 0.2 V, 8 mA DC Bias for LTA1VS16A-351-R and LTA1VS16C-351-R), 0.1 V for LTA1VS16B-351-R)
- Leakage Inductance (Transformer side, short CMC side), Test parameters: 100 kHz, 0.2 V for LTA1VS16A-351-R and LTA1VS16C-351-R), 0.1 V for LTA1VS16B-351-R, CWW (Interwinding capacitance), Pri to Sec: Test parameters: 100 kHz, 0.2 V, for LTA1VS16A-351-R and LTA1VS16C-351-R), 0.1 V for LTA1VS16B-351-R
- Turns ratio, Insertion loss and CMRR (Common mode rejection ratio): Primary to secondary: Polarity pin 1 side in phase
- DCR: CMC side,

- Part number definition: LTA1VS16x-351-R  
LTA1V=Product code  
S16 =Single port  
x: Internal code  
-351: inductance value in  $\mu$ H, third character = # of zeros--351= 350  $\mu$ H  
-R: Rohs compliant
- DCR, CWW, Leakage inductance and Insertion loss values are maximum; Inductance, Return loss, CMRR and Cross talk values are minimum

Mechanical parameters (mm)

LTA1VS16A-351-R/LTA1VS16B-351-R

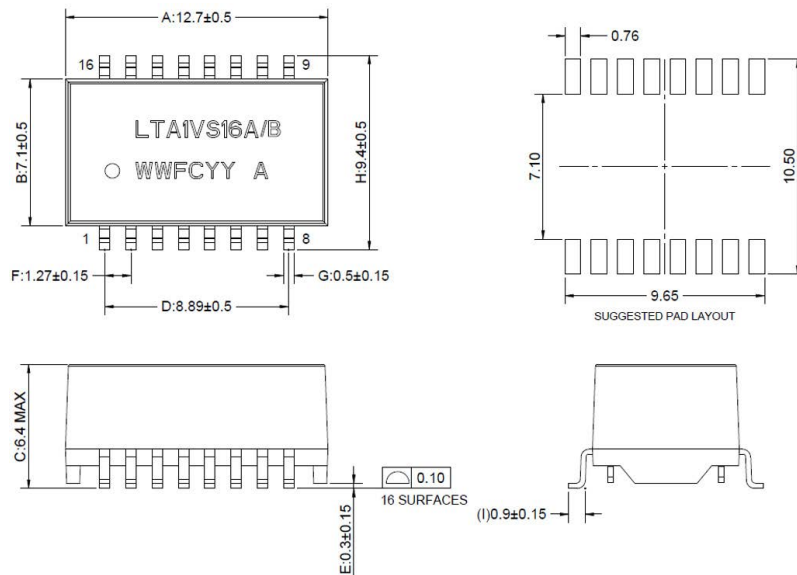

Schematic

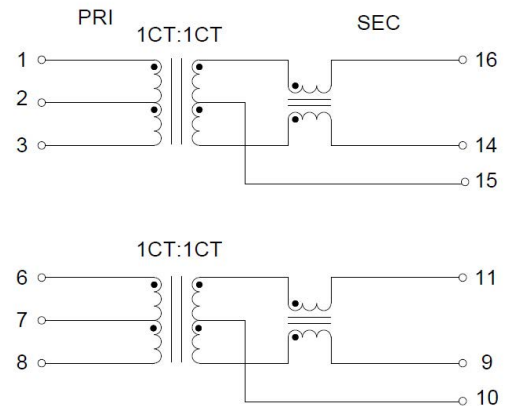

Part marking: LTA1VS16A (LTA1VS16A-351-R), LTA1VS16B (LTA1VS16B-351-R), WWFCYY A = Lot code, Dot indicates pin 1

Pin length does not include include solder point

Silkscreen thickness: 0.1 mm to 0.15 mm

Traces or vias underneath the transformer is not recommended

**Mechanical parameters (mm)**

**LTA1VS16C-351-R**

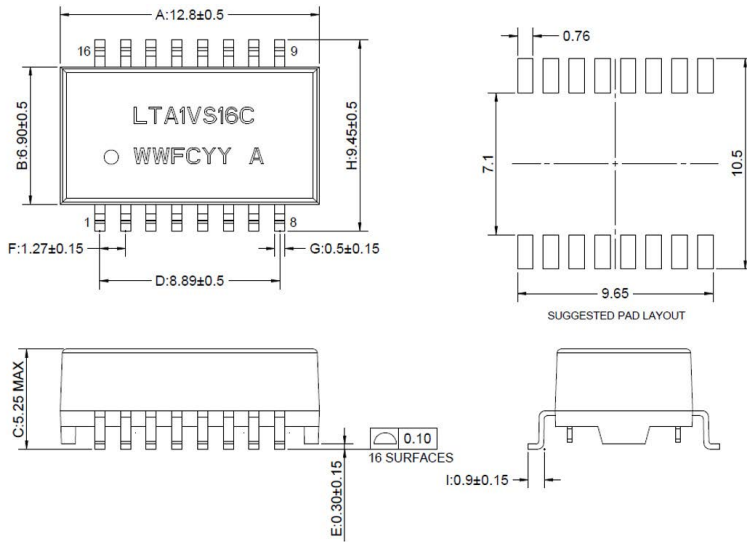

Part marking: LTA1VS16C, WWFCYY A = Lot code, Dot indicates pin 1

Pin length does not include solder point

Silkscreen thickness: 0.1 mm to 0.15 mm

Traces or vias underneath the transformer is not recommended

**Schematic**

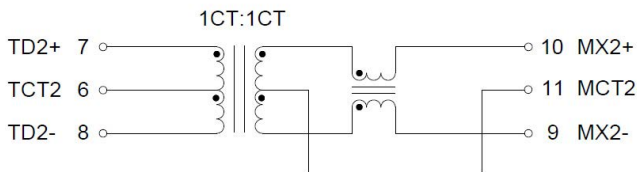
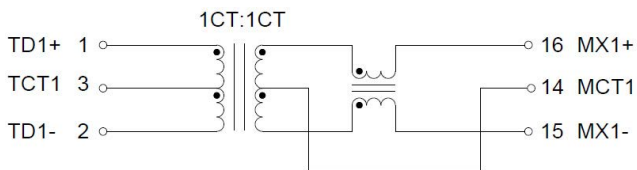

### Packaging information (mm)

Drawing not to scale

Supplied in tape and reel packaging on a 13" diameter reel, EIA-481 compliant

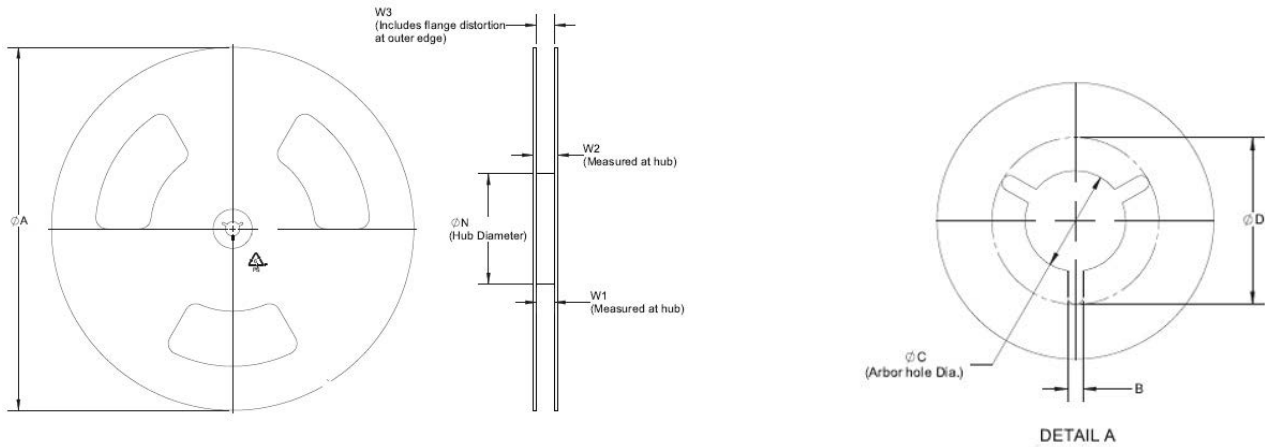

### Reel dimension (mm)

ØA	B	ØC	ØD	ØN	W1	W2	W3
330±1	2.3±0.5	13.3	20±1	100	24.4+2/-0	31 maximum	N/A

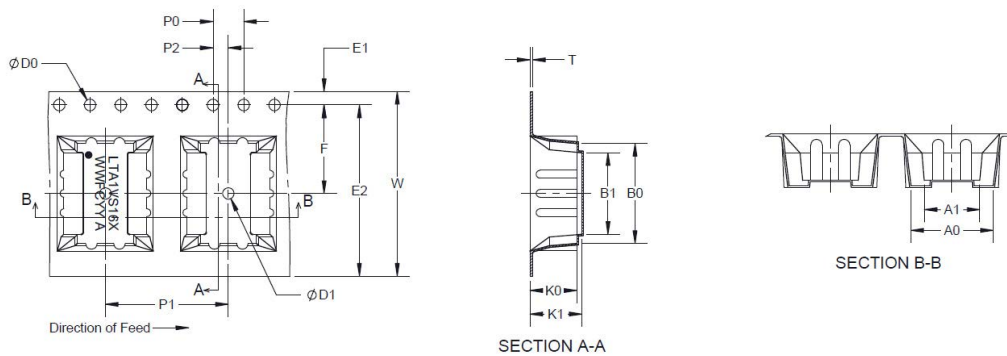

### Tape dimension (mm)

Part number	Ao	A1	Bo	B1	Ko	K1	T	W	F	E1	E2	P0	P1	P2	ØD0	ØD1
LTA1VS16A/B-351-R	10.8 ±0.1	7.3 ref	13.1 ±0.1	11.66 ref	6.1 ±0.1	6.75 ±0.1	0.4 ±0.05	24 ±0.3	11.5 ±0.1	1.75 ±0.1	N/A	4.0 ±0.1	16 ±0.1	2.0 ±0.1	1.5 +0.1/-0	1.5 +0.1/-0
LTA1VS16C-351-R	10.45 ±0.1	7.2 ref	13.1 ±0.1	10.45 r ef	5.1 ±0.1	5.7 ±0.1	0.4 ±0.05	24 ±0.3	11.5 ±0.1	1.75 ±0.1	N/A	4.0 ±0.1	16 ±0.1	2.0 ±0.15	1.5 +0.1/-0	1.5 +0.1/-0

### Packaging quantity

Reel	Bag	Box	Carton
600	600	1200	4800

Solder reflow profile

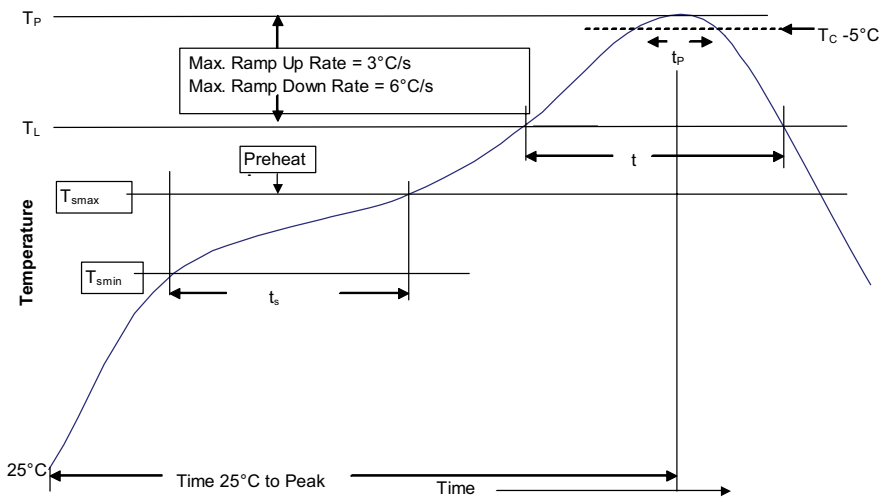

Table 1 - Standard SnPb solder (T<sub>c</sub>)

Package thickness	Volume mm <sup>3</sup> <350	Volume mm <sup>3</sup> ≥350
<2.5 mm	235 °C	220 °C
≥2.5 mm	220 °C	220 °C

Table 2 - Lead (Pb) free solder (T<sub>c</sub>)

Package thickness	Volume mm <sup>3</sup> <350	Volume mm <sup>3</sup> 350 - 2000	Volume mm <sup>3</sup> >2000
<1.6 mm	260 °C	260 °C	260 °C
1.6 - 2.5 mm	260 °C	250 °C	245 °C
>2.5 mm	250 °C	245 °C	245 °C

Reference J-STD-020

Profile feature	Standard SnPb solder	Lead (Pb) free solder
Preheat and soak		
• Temperature min. (T <sub>smin</sub> )	100 °C	150 °C
• Temperature max. (T <sub>smax</sub> )	150 °C	200 °C
• Time (T <sub>smin</sub> to T <sub>smax</sub> ) (t <sub>s</sub> )	60-120 seconds	60-120 seconds
Ramp up rate T <sub>L</sub> to T <sub>P</sub>	3 °C/ second max.	3 °C/ second max.
Liquidous temperature (T <sub>L</sub> )	183 °C	217 °C
Time (t <sub>l</sub> ) maintained above T <sub>L</sub>	60-150 seconds	60-150 seconds
Peak package body temperature (T <sub>P</sub> )*	Table 1	Table 2
Time (t <sub>p</sub> )* within 5 °C of the specified classification temperature (T <sub>c</sub> )	20 seconds*	30 seconds*
Ramp-down rate (T <sub>P</sub> to T <sub>L</sub> )	6 °C/ second max.	6 °C/ second max.
Time 25 °C to peak temperature	6 minutes max.	8 minutes max.

\* Tolerance for peak profile temperature (T<sub>p</sub>) is defined as a supplier minimum and a user maximum.

Life Support Policy: Eaton does not authorize the use of any of its products for use in life support devices or systems without the express written approval of an officer of the Company. Life support systems are devices which support or sustain life, and whose failure to perform, when properly used in accordance with instructions for use provided in the labeling, can be reasonably expected to result in significant injury to the user.

Eaton reserves the right, without notice, to change design or construction of any products and to discontinue or limit distribution of any products. Eaton also reserves the right to change or update, without notice, any technical information contained in this bulletin.

**Eaton**  
Electronics Division  
1000 Eaton Boulevard  
Cleveland, OH 44122  
United States  
Eaton.com/electronics

© 2023 Eaton  
All Rights Reserved  
Printed in USA  
Publication No. ELX1396 BU-ELX22268  
December 2023

Eaton is a registered trademark.

All other trademarks are property of their respective owners.

Follow us on social media to get the latest product and support information.

