

# LD2-HV

## High-voltage metalized drum core inductor



### Product features

- Metalized drum core design utilizes less board space
- Isolation voltage up to 1000 V
- High  $I_{sat}$  rating
- 8.1 mm x 7.3 mm footprint surface mount package in a 5.3 mm height
- Current range from 0.25 A to 6.0 A
- Inductance range from 1.0  $\mu$ H to 2200  $\mu$ H
- Ferrite core material
- Moisture sensitivity level (MSL): 1

### Applications

- Computing
- Laptops, workstations
- LAN /WAN applications
- Game consoles
- Industrial IoT equipment, sensors, power supplies
- Battery backup
- Wireless TX/RX modules
- LED lighting
- Renewable energy products: solar/wind generators, inverters, charger controllers
- Medical equipment: displays, backup power
- High tech consumer products
- Wearables
- Consumer electronics

### Environmental compliance and general specifications

- Storage temperature range (component): -25 °C to +125 °C
- Operating temperature range: -25 °C to +125 °C (ambient plus self-temperature rise)
- Solder reflow temperature: J-STD-020 (latest revision) compliant



Product specifications

Part number <sup>4</sup>	OCL <sup>1</sup> ( $\mu$ H)	FLL <sup>2</sup> ( $\mu$ H) minimum	I <sub>avg</sub> <sup>3</sup> (A) typical	I <sub>rms</sub> <sup>5</sup> (A) typical	DCR (m $\Omega$ ) @ +20 °C maximum	Impulse test voltage (Pin 1 to Pin 2) V	Hi-pot test voltage (Winding to core)
LD2-1R0-HV	1.0 $\pm$ 30%	0.56	6.0	NA	15	1100	1000 Vac ; 60 s ; 3 mA
LD2-1R5-HV	1.5 $\pm$ 30%	0.84	5.5	NA	17	1100	1000 Vac ; 60 s ; 3 mA
LD2-2R2-HV	2.2 $\pm$ 20%	1.41	5.0	NA	20	1100	1000 Vac ; 60 ss 3 mA
LD2-3R3-HV	3.3 $\pm$ 20%	2.11	4.5	NA	28	1100	1000 Vac ; 60 s ; 3 mA
LD2-4R7-HV	4.7 $\pm$ 20%	3.0	4.0	NA	36	1100	1000 Vac ; 60 s ; 3 mA
LD2-6R8-HV	6.8 $\pm$ 20%	4.35	3.5	NA	40	1100	1000 Vac ; 60 s ; 3 mA
LD2-100-HV	10 $\pm$ 20%	6.4	2.5	NA	60	1100	1000 Vac ; 60 s ; 3 mA
LD2-150-HV	15 $\pm$ 20%	9.6	2.2	NA	85	1100	1000 Vac ; 60 s ; 3 mA
LD2-220-HV	22 $\pm$ 20%	14.1	2.0	NA	100	1100	1000 Vac ; 60 s ; 3 mA
LD2-330-HV	33 $\pm$ 20%	21.1	1.5	NA	150	1000	1000 Vac ; 60 s ; 3 mA
LD2-470-HV	47 $\pm$ 20%	30.1	1.2	NA	200	1000	1000 Vac ; 60 s ; 3 mA
LD2-680-HV	68 $\pm$ 20%	43.5	1.0	NA	270	1000	1000 Vac ; 60 s ; 3 mA
LD2-820-HV	82 $\pm$ 20%	52.5	0.9	NA	300	1000	1000 Vac ; 60 s ; 3 mA
LD2-101-HV	100 $\pm$ 20%	64.0	0.8	NA	380	900	1000 Vac ; 60 s ; 3 mA
LD2-221-HV	220 $\pm$ 20%	140.8	0.5	NA	750	800	1000 Vac ; 60 s ; 3 mA
LD2-331-HV	330 $\pm$ 20%	211.2	0.4	NA	1420	700	1000 Vac ; 60 s ; 3 mA
LD2-471-HV	470 $\pm$ 20%	300.8	0.53	0.67	1900	700	1000 Vac ; 60 s ; 3 mA
LD2-561-HV	560 $\pm$ 20%	358.4	0.5	0.61	2000	700	1000 Vac ; 60 s ; 3 mA
LD2-681-HV	680 $\pm$ 20%	435.2	0.44	0.53	2500	600	1000 Vac ; 60 s ; 3 mA
LD2-821-HV	820 $\pm$ 20%	524.8	0.41	0.5	3200	600	1000 Vac ; 60 s ; 3 mA
LD2-102-HV	1000 $\pm$ 20%	640.0	0.36	0.44	4000	600	500 Vac ; 60 s ; 3 mA
LD2-122-HV	1200 $\pm$ 20%	768.0	0.33	0.4	4500	600	500 Vac ; 60 s ; 3 mA
LD2-152-HV	1500 $\pm$ 20%	960.0	0.31	0.36	5500	600	500 Vac ; 60 s ; 3 mA
LD2-222-HV	2200 $\pm$ 20%	1408.0	0.25	0.3	10000	300	500 Vac ; 60 s ; 3 mA

1. Open circuit inductance (OCL) test parameters: 100 kHz, 0.25 V<sub>rms</sub>, 0.0 Adc, +25 °C

2. Full load inductance (FLL) test parameters: 100 kHz, 0.25 V<sub>rms</sub>, I<sub>avg</sub>, +25 °C

3. I<sub>avg</sub>: Peak current for approximately 20% rolloff @ +25 °C

4. Part number definition: LD2-xxx-HV

LD2 = Product code

xxx= Inductance value in  $\mu$ H, R=decimal point

-HV suffix = High voltage capability

5. I<sub>rms</sub>: DC current for an approximate temperature rise of 40 °C without core loss. Derating is necessary for AC currents. PCB layout, trace thickness and width, air-flow, and proximity of other heat generating components will affect the temperature rise. It is recommended that the temperature of the part not exceed +125 °C under worst case operating conditions verified in the end application

**Dimensions-mm**

**LD2-HV**

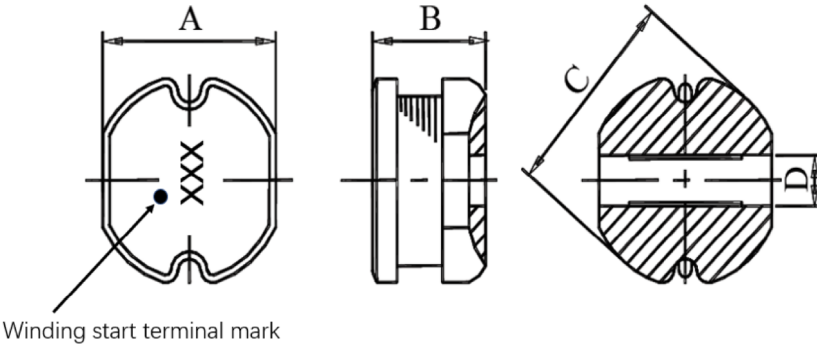

**Pad layout**

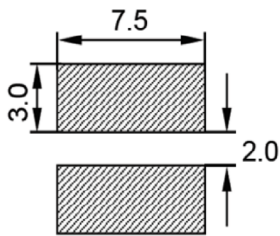

**Schematic**

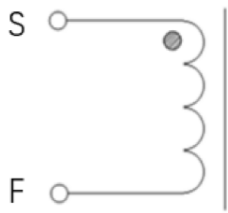

Dimension	Value
A	7.0 ± 0.3
B	5.0 ± 0.3
C	7.8 ± 0.3
D	2.5 reference

Part marking: xxx= inductance value in  $\mu\text{H}$ , R= decimal point. If no R is present then last character equals number of zeros.  
 Tolerances are  $\pm 0.2$  millimeters unless stated otherwise  
 All soldering surfaces to be coplanar within 0.1 millimeters  
 Pad layout tolerances are  $\pm 0.1$  millimeters unless stated otherwise  
 Traces or vias underneath the inductor is not recommended

**Packaging information- mm**

**LD2-HV**

Supplied in tape and reel packaging, 1000 parts per 13" diameter reel (EIA-481 compliant)

Drawing not to scale

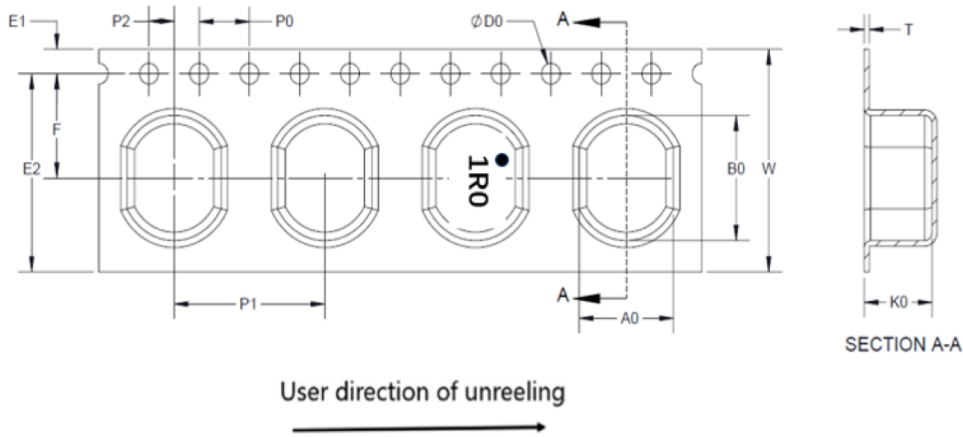

Dimension	Value
W	16.00 ± 0.30
F	7.50 ± 0.10
E1	1.75 ± 0.10
E2	N/A
P0	4.00 ± 0.10
P1	12.00 ± 0.10
P2	2.00 ± 0.10
$\phi D0$	1.50 ± 0.10
$\phi D1$	N/A
A0	7.50 ± 0.10
B0	9.00 ± 0.10
K0	5.40 ± 0.10
T	0.40 ± 0.05

Inductance and temperature rise vs current

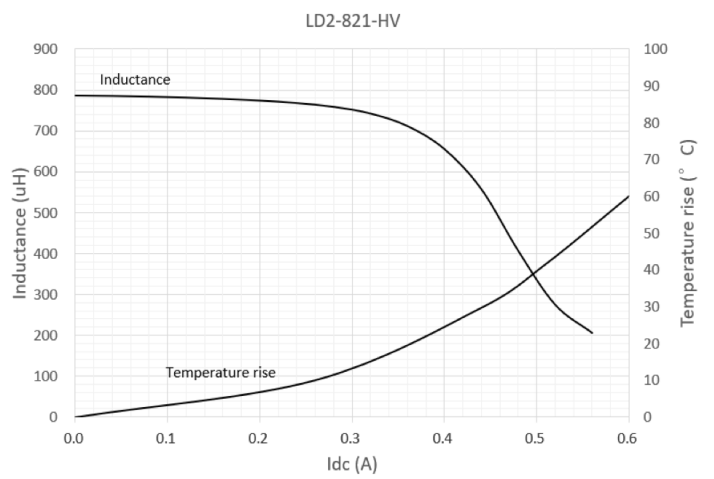
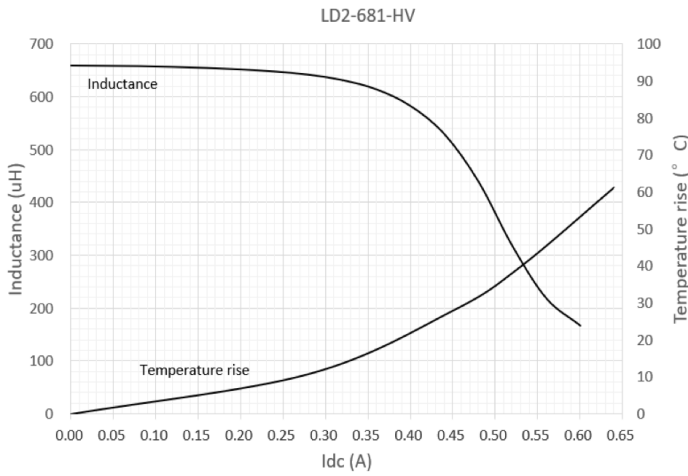
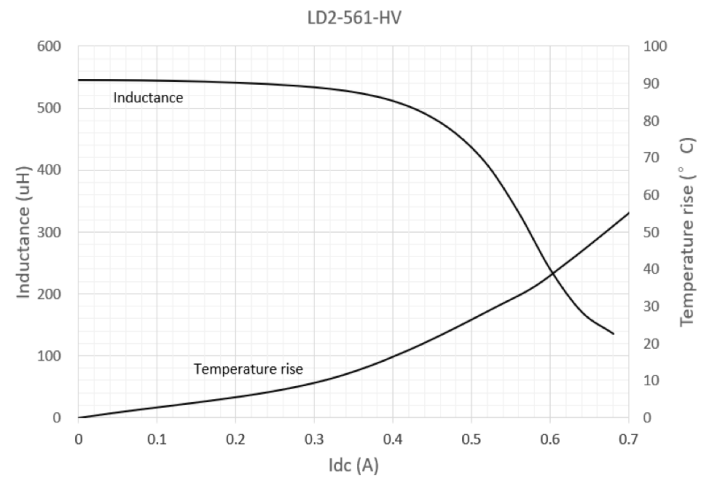
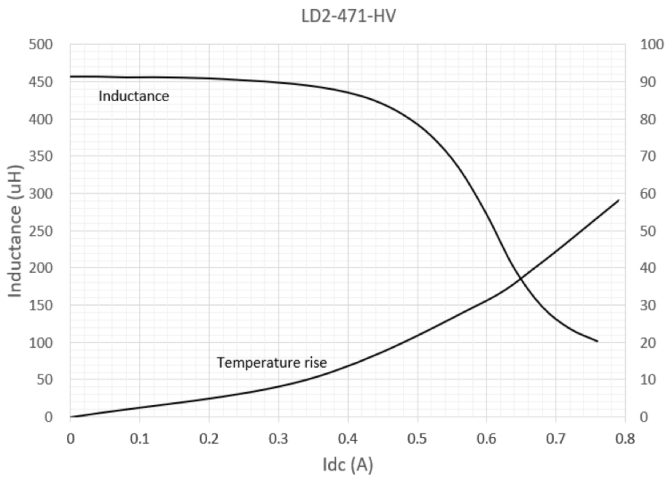

Inductance and temperature rise vs current

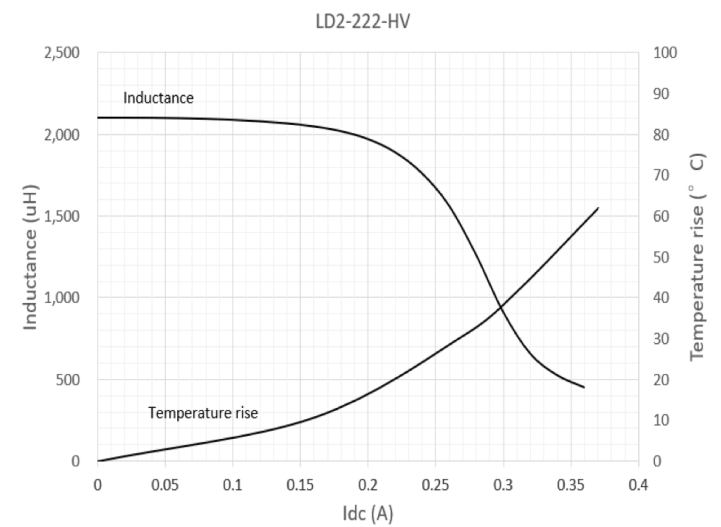
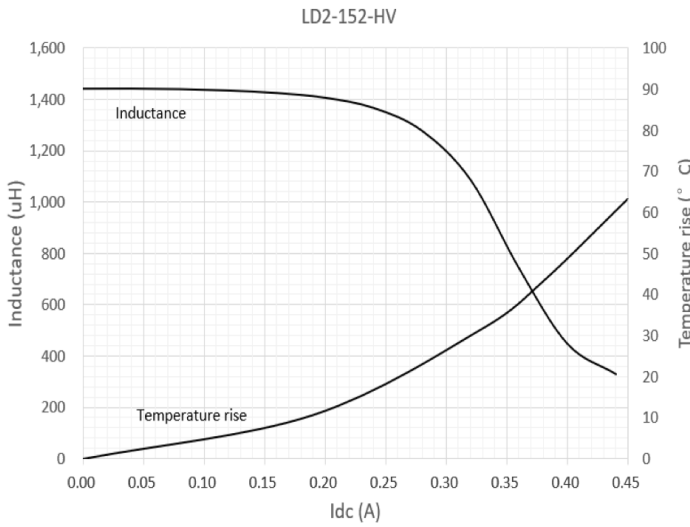
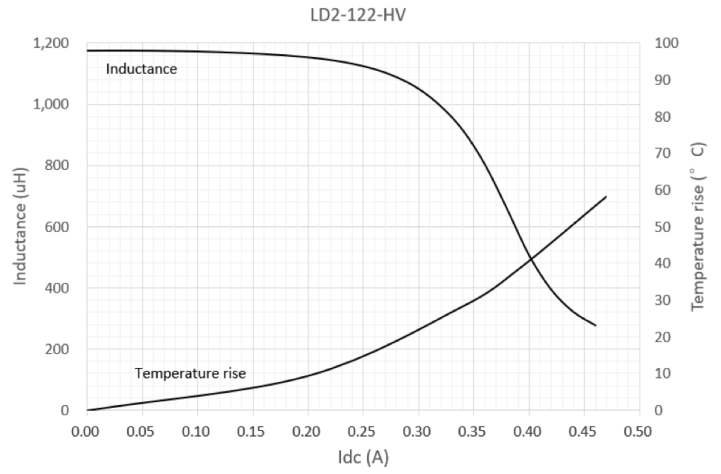
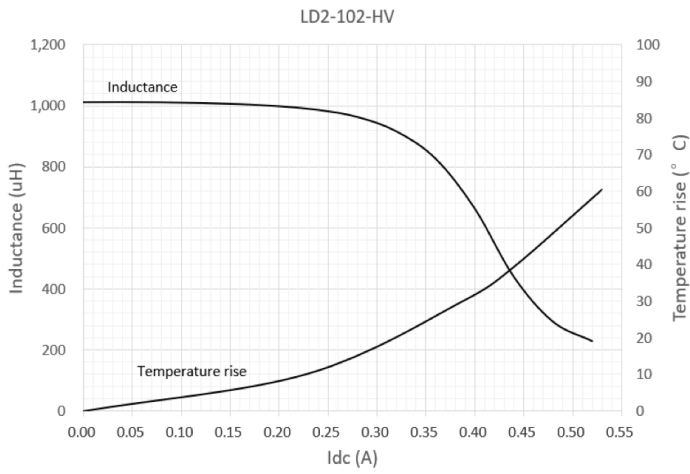

Solder reflow profile

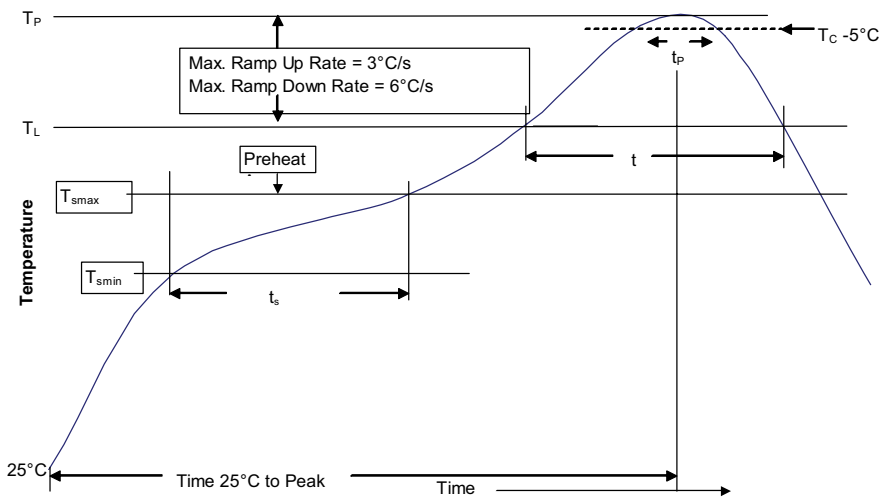

Table 1 - Standard SnPb solder (T<sub>C</sub>)

Package thickness	Volume mm <sup>3</sup> <350	Volume mm <sup>3</sup> ≥350
<2.5 mm	235 °C	220 °C
≥2.5 mm	220 °C	220 °C

Table 2 - Lead (Pb) free solder (T<sub>C</sub>)

Package thickness	Volume mm <sup>3</sup> <350	Volume mm <sup>3</sup> 350 - 2000	Volume mm <sup>3</sup> >2000
<1.6 mm	260 °C	260 °C	260 °C
1.6 – 2.5 mm	260 °C	250 °C	245 °C
>2.5 mm	250 °C	245 °C	245 °C

Reference J-STD-020

Profile feature	Standard SnPb solder	Lead (Pb) free solder
Preheat and soak		
• Temperature min. (T <sub>smin</sub> )	100 °C	150 °C
• Temperature max. (T <sub>smax</sub> )	150 °C	200 °C
• Time (T <sub>smin</sub> to T <sub>smax</sub> ) (t <sub>s</sub> )	60-120 seconds	60-120 seconds
Ramp up rate T <sub>L</sub> to T <sub>p</sub>	3 °C/ second max.	3 °C/ second max.
Liquidous temperature (T <sub>L</sub> )	183 °C	217 °C
Time (t <sub>L</sub> ) maintained above T <sub>L</sub>	60-150 seconds	60-150 seconds
Peak package body temperature (T <sub>p</sub> )*	Table 1	Table 2
Time (t <sub>p</sub> )* within 5 °C of the specified classification temperature (T <sub>C</sub> )	20 seconds*	30 seconds*
Ramp-down rate (T <sub>p</sub> to T <sub>L</sub> )	6 °C/ second max.	6 °C/ second max.
Time 25 °C to peak temperature	6 minutes max.	8 minutes max.

\* Tolerance for peak profile temperature (T<sub>p</sub>) is defined as a supplier minimum and a user maximum.

Life Support Policy: Eaton does not authorize the use of any of its products for use in life support devices or systems without the express written approval of an officer of the Company. Life support systems are devices which support or sustain life, and whose failure to perform, when properly used in accordance with instructions for use provided in the labeling, can be reasonably expected to result in significant injury to the user.

Eaton reserves the right, without notice, to change design or construction of any products and to discontinue or limit distribution of any products. Eaton also reserves the right to change or update, without notice, any technical information contained in this bulletin.

**Eaton**  
Electronics Division  
1000 Eaton Boulevard  
Cleveland, OH 44122  
United States  
Eaton.com/electronics

© 2022 Eaton  
All Rights Reserved  
Printed in USA  
Publication No. ELX1200 BU-ELX22060  
June 2022

Eaton is a registered trademark.  
All other trademarks are property of their respective owners.

Follow us on social media to get the latest product and support information.

