

EREC0502K

Hyperfast soft recovery rectifier

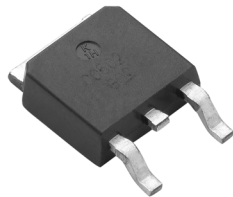

Product features

- Plastic package UL 94V-0
- Low reverse leakage current
- Hyperfast recovery time and soft recovery characteristics
- Low recovery loss

Mechanical data

- Case: TO-252 molded plastic
- Terminals: Tin plated
- Weight: 0.329 grams typical

Package diagram/size and schematic



TO-252

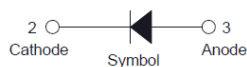

| | |
|---|---------------|
| 1 | No connection |
| 2 | Cathode |
| 3 | Anode |

Applications

- Switching mode power supplies (SMPS)
- Inverters
- Freewheeling diodes
- DC/DC converters
- Other power switching application

Environmental data



Part numbering system

| | | | | | | |
|---|---|---|---|----|----|---|
| E | R | E | C | 05 | 02 | K |
| 1 | 2 | 3 | 4 | 5 | 6 | 7 |

| | |
|---|-----------------------|
| 1 | E=Eaton |
| 2 | R=Rectifier |
| 3 | E=Epitaxial process |
| 4 | C=Hyperfast |
| 5 | 05= $I_{F(AV)}$: 5 A |
| 6 | 02= V_{RRM} : 200 V |
| 7 | K=Package: TO-252 |

Absolute maximum rating

(Rating at +25 °C ambient temperature unless otherwise specified)

| Parameter | Symbol | Value | Unit |
|--|----------------|-------------|------|
| Maximum repetitive peak reverse voltage | V_{RRM} | 200 | V |
| Maximum RMS voltage | V_{RMS} | 140 | V |
| Maximum DC blocking voltage | V_{DC} | 200 | V |
| Average forward current at $T_c = +120$ °C | $I_{F(AV)}$ | 5 | A |
| Peak forward surge current: 8.3 ms single half sinewave superimposed on rated load | I_{FSM} | 65 | A |
| Operating junction and storage temperature range | T_j, T_{stg} | -55 to +150 | °C |

Electrical characteristics

(Rating at +25 °C ambient temperature unless otherwise specified)

| Parameter | Test condition | Symbol | min | typ | max | Unit |
|--|---|----------|-----|-----|------|------|
| Forward voltage @ $I_F=5$ A | $T_j=25$ °C | V_F | - | - | 0.95 | V |
| Reverse current at rated DC blocking voltage | $T_j=25$ °C | I_R | - | - | 5 | μA |
| | $T_j=125$ °C | I_R | - | - | 200 | μA |
| Reverse recovery time | $I_F=0.5$ A, $I_R=1.0$ A, $IRR=0.25$ A, $T_j=25$ °C | t_{rr} | - | - | 25 | ns |

Thermal resistances

| Symbol | Parameter | min | typ | max | Unit |
|---------------|--|-----|-----|-----|-------|
| $R_{th(j-c)}$ | Thermal resistance from junction to case | - | - | 14 | °C /W |

Mechanical drawing, pad layout, marking-mm

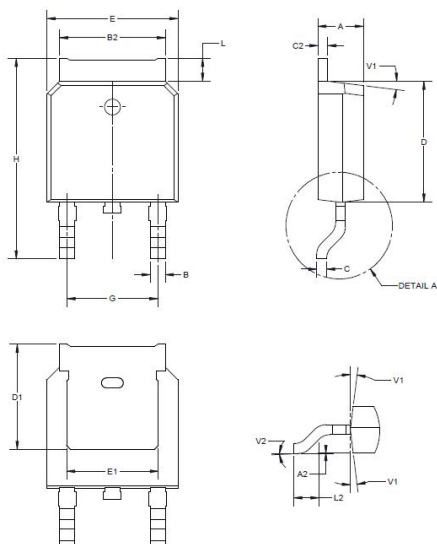

| Dimension | min | typ | max |
|-----------|------|---------|-------|
| A | 2.10 | | 2.50 |
| A2 | - | | 0.10 |
| B | 0.66 | | 0.86 |
| B2 | 5.18 | | 5.48 |
| C | 0.40 | | 0.60 |
| C2 | 0.44 | | 0.58 |
| D | 5.90 | | 6.30 |
| D1 | - | 5.30REF | - |
| E | 6.40 | | 6.80 |
| E1 | 4.63 | | - |
| G | 4.47 | | 4.67 |
| H | 9.50 | | 10.70 |
| L | 1.09 | | 1.21 |
| L2 | 1.35 | | 1.65 |
| V1 | - | 7° | - |
| V2 | - | | 6° |

Marking



Product information

| | |
|-----|-------------------|
| C | Hyperfast |
| 05 | $I_{F(AV)}$: 5 A |
| 02 | V_{RRM} : 200 V |
| K | Package: TO-252 |
| F35 | Date code |

Packaging information-mm (EIA-481 compliant)

| Unit weight (g/pcs) typ. | Reel (pcs) | Per carton (pcs) | Reel diameters (mm) |
|--------------------------|------------|------------------|---------------------|
| 0.329 | 2,500 | 25,000 | 330 |

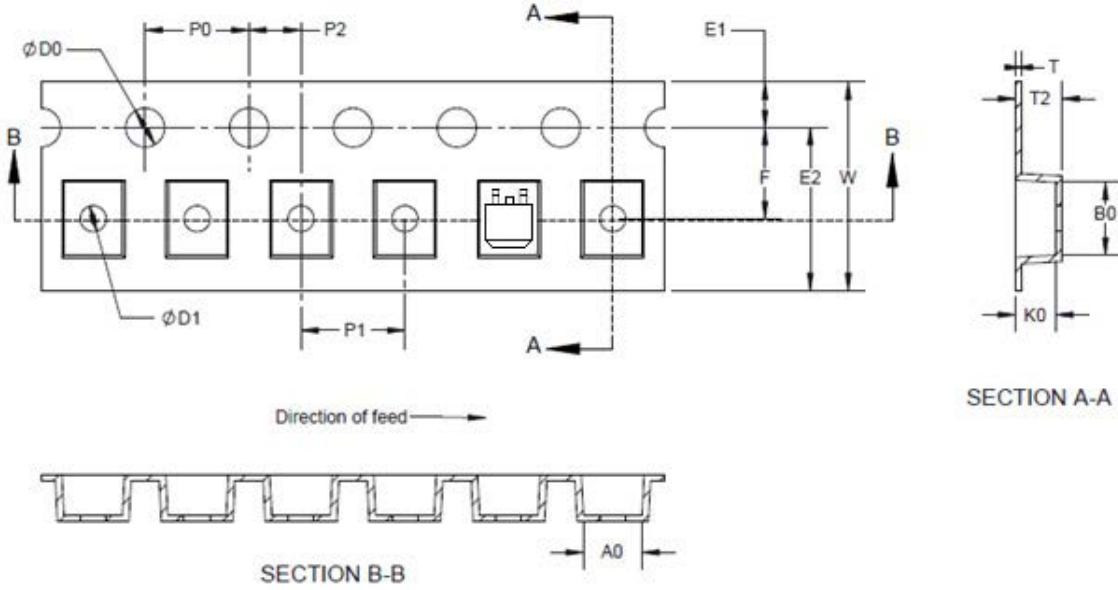

| Dimension | Tolerance | Value |
|-----------|------------|-------|
| W | ± 0.20 | 16 |
| F | ± 0.10 | 7.5 |
| E1 | ± 0.10 | 1.75 |
| P0 | ± 0.10 | 4 |
| P1 | ± 0.10 | 8 |
| P2 | ± 0.10 | 2 |
| D0 | $+0.1/-0$ | 1.5 |
| D1 | $+0.1/-0$ | 1.5 |
| A0 | ± 0.10 | 6.9 |
| B0 | ± 0.10 | 10.5 |
| K0 | ± 0.10 | 2.7 |
| T | ± 0.10 | 0.3 |
| T2 | ± 0.20 | 3 |

Typical characteristics

Typical forward characteristics (+25 °C)

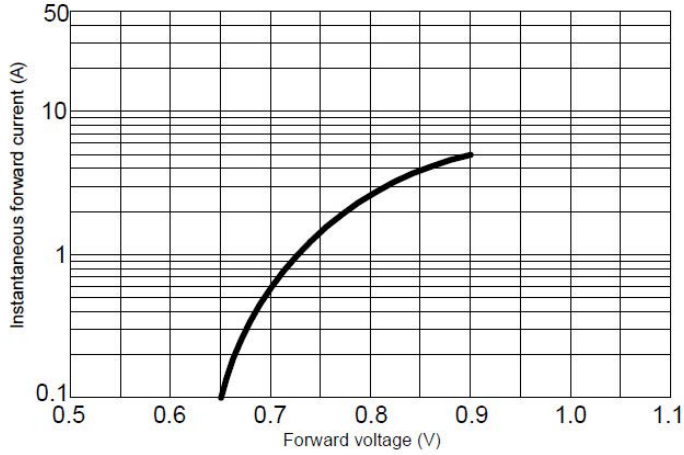

Typical reverse characteristics

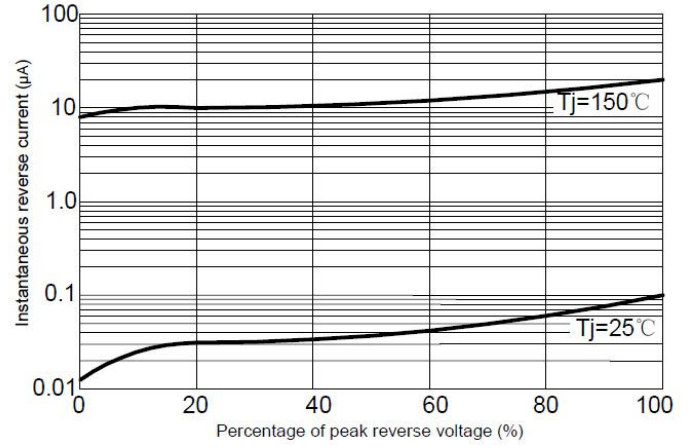

Maximum non-repetitive peak forward surge current (8.3ms single half sine-wave) (+25 °C)

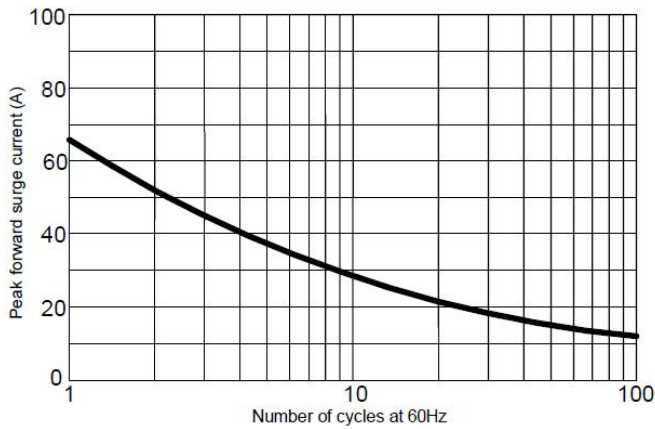

Forward current derating curve

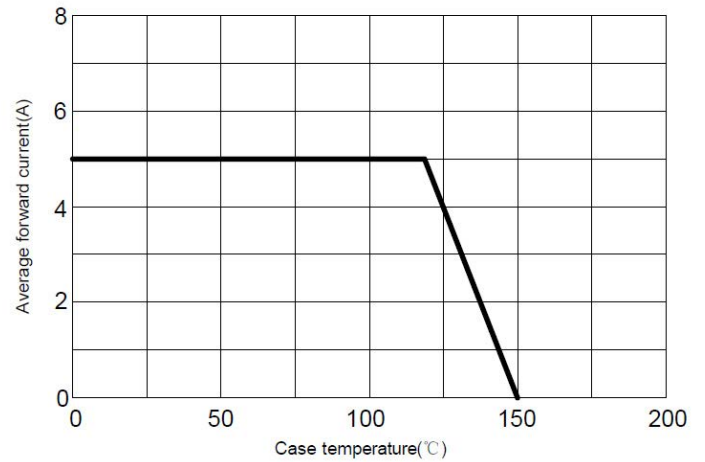

Solder reflow profile

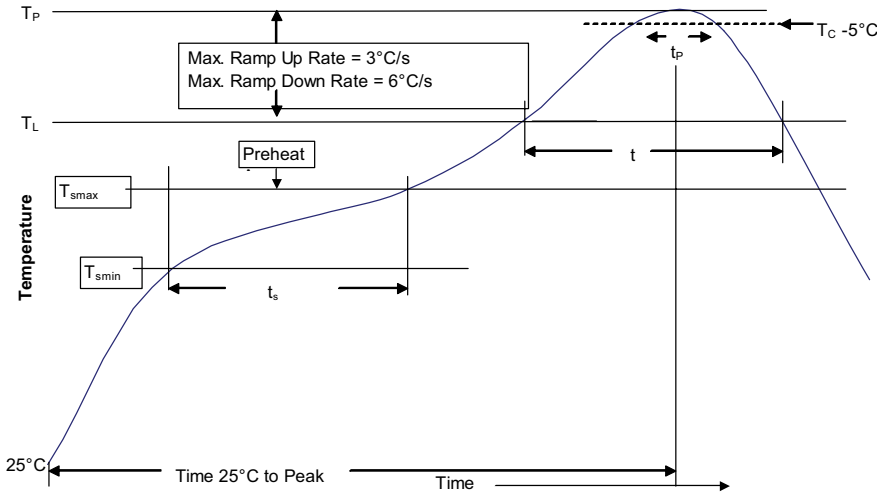

Table 1 - Standard SnPb solder (T_C)

| Package thickness | Volume mm ³ <350 | Volume mm ³ ≥350 |
|-------------------|-----------------------------|-----------------------------|
| <2.5 mm | 235 °C | 220 °C |
| ≥2.5 mm | 220 °C | 220 °C |

Table 2 - Lead (Pb) free solder (T_C)

| Package thickness | Volume mm ³ <350 | Volume mm ³ 350 - 2000 | Volume mm ³ >2000 |
|-------------------|-----------------------------|-----------------------------------|------------------------------|
| <1.6 mm | 260 °C | 260 °C | 260 °C |
| 1.6 – 2.5 mm | 260 °C | 250 °C | 245 °C |
| >2.5 mm | 250 °C | 245 °C | 245 °C |

Reference J-STD-020

| Profile feature | Standard SnPb solder | Lead (Pb) free solder |
|---|--|--|
| Preheat and soak | <ul style="list-style-type: none"> Temperature min. (T_{smin}) Temperature max. (T_{smax}) Time (T_{smin} to T_{smax}) (t_s) | <ul style="list-style-type: none"> 100 °C 150 °C 60-120 seconds |
| Ramp up rate T_L to T_p | 3 °C/ second max. | 3 °C/ second max. |
| Liquidous temperature (T_L) Time (t_L) maintained above T_L | <ul style="list-style-type: none"> 183 °C 60-150 seconds | <ul style="list-style-type: none"> 217 °C 60-150 seconds |
| Peak package body temperature (T_p)* | Table 1 | Table 2 |
| Time (t_p)* within 5 °C of the specified classification temperature (T_C) | 20 seconds* | 30 seconds* |
| Ramp-down rate (T_p to T_L) | 6 °C/ second max. | 6 °C/ second max. |
| Time 25 °C to peak temperature | 6 minutes max. | 8 minutes max. |

* Tolerance for peak profile temperature (T_p) is defined as a supplier minimum and a user maximum.

Life Support Policy: Eaton does not authorize the use of any of its products for use in life support devices or systems without the express written approval of an officer of the Company. Life support systems are devices which support or sustain life, and whose failure to perform, when properly used in accordance with instructions for use provided in the labeling, can be reasonably expected to result in significant injury to the user.

Eaton reserves the right, without notice, to change design or construction of any products and to discontinue or limit distribution of any products. Eaton also reserves the right to change or update, without notice, any technical information contained in this bulletin.

Eaton
Electronics Division
1000 Eaton Boulevard
Cleveland, OH 44122
United States
Eaton.com/electronics

© 2023 Eaton
All Rights Reserved
Printed in USA
Publication No. ELX1292 BU-ELX22155
March 2023

Eaton is a registered trademark.

All other trademarks are property of their respective owners.

Follow us on social media to get the latest product and support information.

