

Installation Instruction for Rotary Handle Mechanism for Cutler-Hammer R-frame Circuit Breakers

WARNING

DO NOT ATTEMPT TO INSTALL OR PERFORM MAINTENANCE ON EQUIPMENT WHILE IT IS ENERGIZED. DEATH OR SEVERE PERSONAL INJURY CAN RESULT FROM CONTACT WITH ENERGIZED EQUIPMENT. ALWAYS VERIFY THAT NO VOLTAGE IS PRESENT BEFORE PROCEEDING.

THE CUTLER-HAMMER IS NOT LIABLE FOR THE MISAPPLICATION OR MISINSTALLATION OF ITS PRODUCTS.

1. GENERAL INFORMATION

The Rotary handle mechanism (Fig.1) is suitable for fabricated enclosures. It is designed for use with R-frame circuit breakers.

The operating mechanism may be padlocked in the OFF position utilizing 3 padlocks (8mm Max).

2. INSTALLATION

Note: Replace the existing cover fastening screws with package supplied when mounting the handle mechanism.

- 2.1 Turn circuit breaker to "OFF" position.
Remove 4 cover fastening screws (1/4-20 x 82) from circuit breaker (Fig.2).

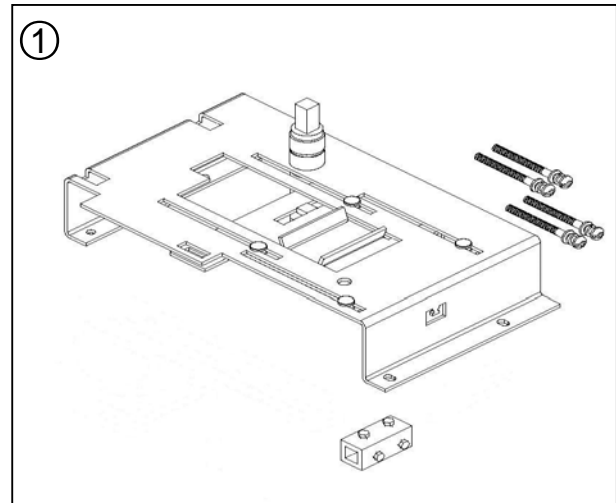
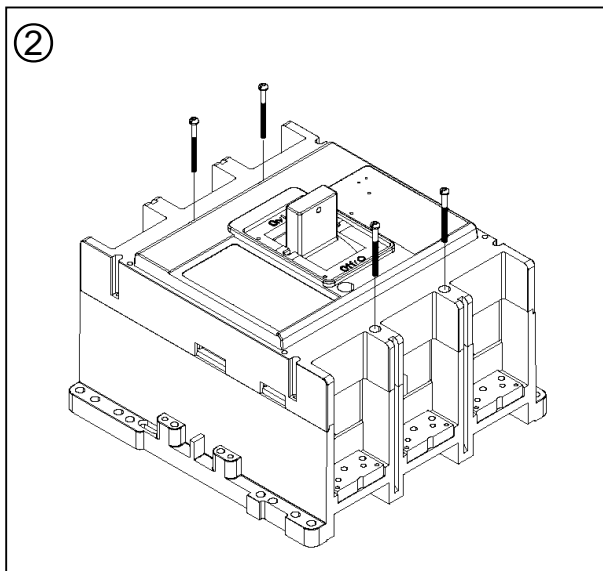

- 2.2 As shown in Fig. 3, mounting mechanism onto circuit breaker, ensuring slide plate is engaged with the circuit breaker handle. Fix mechanism with washers, lockwashers and screws (1/4-20 x 92) by package supplied. Torque to 5 N.m (44.25 in-lb).

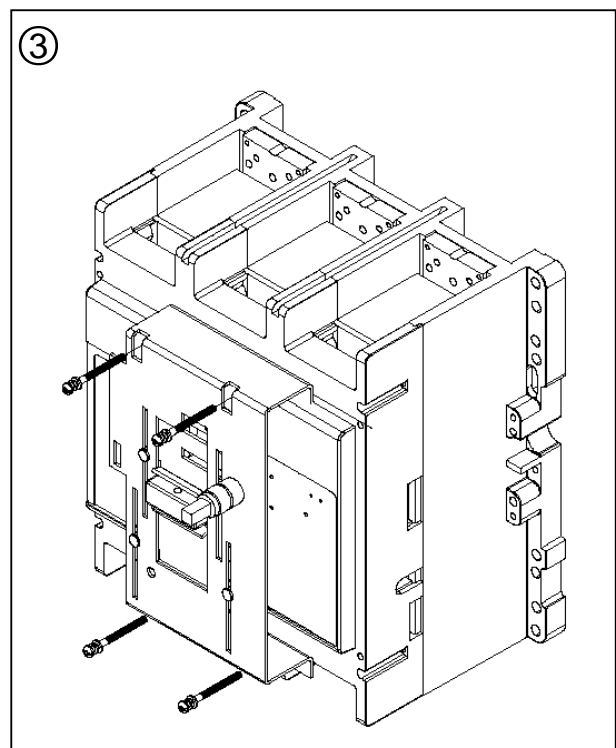

- 2.3 Coupling both the square shaft and operation shaft of mechanism by adapter. Fix drive coupling to square shaft with screws (see Fig.4). Torque to 2.26 N.m (20 in-lb).
- 2.4 Refer to drilling plan (Fig.5). Drill holes and cut enclosure door cover to accept operation handle.

