



**Installation Instructions for Undervoltage Release Mechanism (Handle Reset)
for NDB, ND, NDC, NW, HNW, and NWC Circuit Breakers, Series C Molded Case
Switches, and Motor Circuit Protectors (HMCP)**



WARNING

CONTACT WITH ENERGIZED EQUIPMENT CAN RESULT IN DEATH, SEVERE PERSONAL INJURY, OR SUBSTANTIAL PROPERTY DAMAGE. DO NOT ATTEMPT TO INSTALL OR PERFORM MAINTENANCE ON EQUIPMENT WHILE IT IS ENERGIZED. ALWAYS VERIFY THAT NO VOLTAGE IS PRESENT BEFORE PROCEEDING WITH THE TASK, AND ALWAYS FOLLOW GENERALLY ACCEPTED SAFETY PROCEDURES.

CUTLER-HAMMER IS NOT LIABLE FOR THE MISAPPLICATION OR MISINSTALLATION OF ITS PRODUCTS.

The user is cautioned to observe all recommendations, warnings, and cautions relating to the safety of personnel and equipment as well as all general and local health and safety laws, codes, and procedures.

The recommendations and information contained herein are based on Cutler-Hammer experience and judgement, but should not be considered to be all-inclusive or covering every application or circumstance which may arise. If any questions arise, contact Cutler-Hammer for further information or instructions.

1. INTRODUCTION

General Information

The undervoltage release mechanism (UVR)(Fig. 1-1) monitors a voltage (typically a line voltage) and trips the circuit breaker when the voltage falls to between 70 and 35 percent of the UVR rating. The UVR consists of a continuous rated solenoid with a plunger and reset lever assembled to a plug-in module. The plug-in module is mounted in slots in the top of the trip unit and occupies the accessory cavity in the circuit breaker frame. The reset lever resets the UVR when normal voltage is restored and the circuit breaker handle is moved to the reset (extreme OFF) position. With no voltage applied to the UVR, the circuit breaker contacts will not touch when a closing operation is attempted.

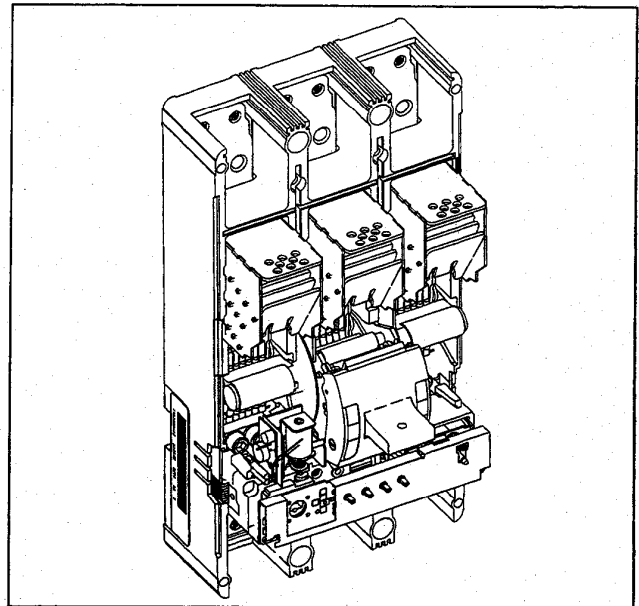

Fig. 1-1. Undervoltage Release Mechanism (Handle Reset) Installed in N-Frame Circuit Breaker

The UVR is available with several voltage ratings for most AC and DC requirements. Table 1-1 and 1-2 list application and electrical rating data for the UVR.

For this publication, the term circuit breaker shall also include molded case switch and motor circuit protector.

Depending on the model ordered, connections for the UVR are in one of four forms. The standard wiring configuration is pigtail leads exiting the rear of the base directly behind the UVR. Optional configurations include a terminal block mounted on the same side of the base as the accessory, leads exiting the side of the base where the accessory is mounted, and leads exiting the rear of the base on the side opposite the accessory. The 18-inch long pigtail leads are color coded for identification: identification labels are provided for pigtail leads and terminal block points. For allowable locations of all accessories, refer to Frame Book 29-105.

Note: When the walking beam interlock is used with the circuit breaker, the rear trough cannot be used for accessory pigtail leads.

This instruction leaflet (IL) gives detailed procedures for installing the UVR.

2. INSTALLATION

Note: The UVR can be field-installed in ND, HND, and NDC circuit breakers under UL File E64983.

The UVR can be field-installed in NW, HNW, and NWC circuit breakers.

The UVR is listed for factory installation under UL File E7819.

For sealed circuit breakers (NDB), Underwriters Laboratories Inc. UL 489 requires that internal accessories be installed at the factory. The UVR is listed for factory installation under UL File E7819.

Where local codes and standards permit and UL listing is not required, internal accessories can be field installed in sealed circuit breakers. In this case, UL listing becomes invalid and the label should be removed.

Before attempting to install the UVR, check that the catalog number is correct as ordered and that the rating of the accessory satisfies job requirements.

The UVR, shown in kit form in Fig. 2-1, is installed in the left accessory mounting cavity of a 2-, 3-, or 4-pole circuit breaker. A UVR must be installed in the circuit breaker

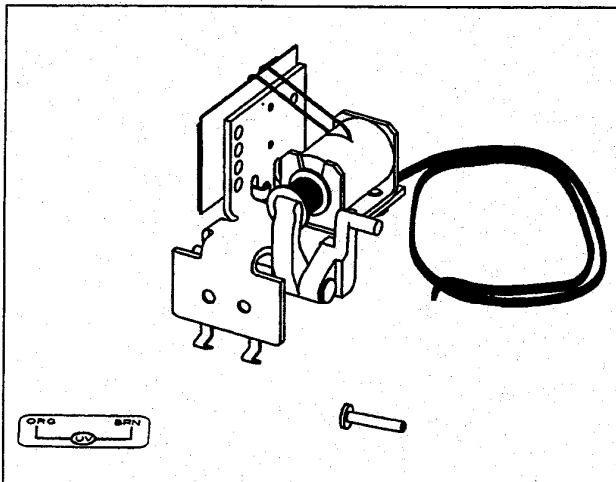

Fig. 2-1. Undervoltage Release Mechanism (Handle Reset) Kit

before the circuit breaker is mounted in an electrical system. To install the UVR, perform the following procedures:



WARNING

BEFORE REMOVING A CIRCUIT BREAKER INSTALLED IN AN ELECTRICAL SYSTEM, MAKE SURE THE CIRCUIT BREAKER IS SWITCHED TO THE OFF POSITION AND THERE IS NO VOLTAGE PRESENT WHERE WORK IS TO BE PERFORMED. SPECIAL ATTENTION SHOULD BE PAID TO REVERSE FEED APPLICATIONS. THE VOLTAGES IN ENERGIZED EQUIPMENT CAN CAUSE DEATH OR SEVERE PERSONAL INJURY.

Note: A circuit breaker that is mounted in an electrical system must be removed to install the accessory. To ensure correct accessory installation, the circuit breaker must be placed on a horizontal surface.

Note: For new circuit breaker installation, trip unit must be installed in circuit breaker before attempting to install a UVR.

2-1. Switch circuit breaker to OFF position.

Note: Molded case switch trip units are not equipped with a PUSH-TO-TRIP button. For molded case switches, omit step 2-3.

2-2. Disconnect and remove circuit breaker from installation and terminal connections.

2-3. Press PUSH-TO-TRIP button to trip operating mechanism, and check that the handle moves to TRIP position with white colored indicator visible in the breaker cover's escutcheon window.

2-4. Remove circuit breaker cover screws and covers.

Note: To install UVR, circuit breaker operating mechanism must be in tripped position and the handle is pushed to "ON" position. (Fig. 2-3)

2-5. Remove interphase barrier between accessory mounting cavity and operating mechanism (see Fig. 2-2).

2-6. Rotate 180° and reinstall interphase barrier in base (see Fig. 2-2).

- 2-7. Install UVR as described in following steps (see Fig. 2-3):
- Press trip button to trip breaker to "TRIP" position.
 - Push circuit breaker handle towards the ON position and hold while sliding UVR plug-in module into slots in trip unit (Fig. 2-3) until retaining clip snaps into trip unit. For terminal block assemblies, slide terminal block into mounting slot on side of base as plug-in module is being positioned.

Note: For a UVR having rear or opposite-side exiting pigtail leads, (Fig. 2-4) thread leads through center trough in side of base before attempting to insert the mounting bracket. Pigtail leads exiting in this manner should be eased through trough as mounting bracket is inserted into trip unit retaining slots. Use center trough also for leads exiting the side of the circuit breaker.



CAUTION

LEADS SHOULD BE FORMED AND ROUTED TO CLEAR ALL MOVING PARTS WHEN ACCESSORY IS PROPERLY INSTALLED. PIGTAIL WIRES COULD BE DAMAGED IF IN CONTACT WITH MOVING PARTS.

- 2-8. Route wiring to meet installation requirements (Fig. 2-4). If required, complete routing of leads to opposite side through rear wiring trough.



WARNING

FAILURE TO KEEP FINGERS AWAY FROM MOVING PARTS CAN CAUSE PERSONAL INJURY. WHEN CHECKING ACCESSORY, DO NOT PUT FINGERS NEAR MOVING PARTS INSIDE CIRCUIT BREAKER CASE. SPRINGS CAUSE INTERNAL PARTS TO MOVE QUICKLY AND WITH FORCE.

- 2-9. Perform mechanical check of UVR after installation:
- With the circuit breaker still electrically isolated, reset the circuit breaker.
 - Mechanical check. Using a small flat-blade screwdriver, (Fig 2-5), push in and hold solenoid plunger. Switch circuit breaker to ON. Release solenoid plunger and check that circuit breaker trips.
 - Reset circuit breaker handle and check that handle arm moves reset lever (Fig. 2-5) to reset the solenoid plunger.

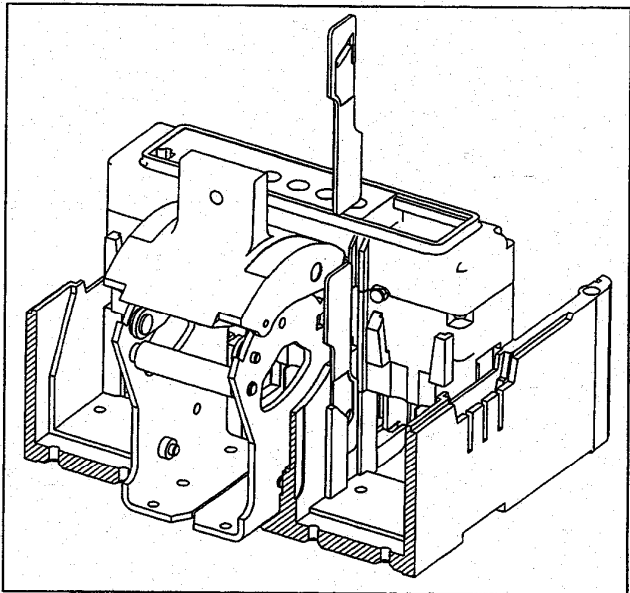

Fig. 2-2. Interphase Barrier Replacement

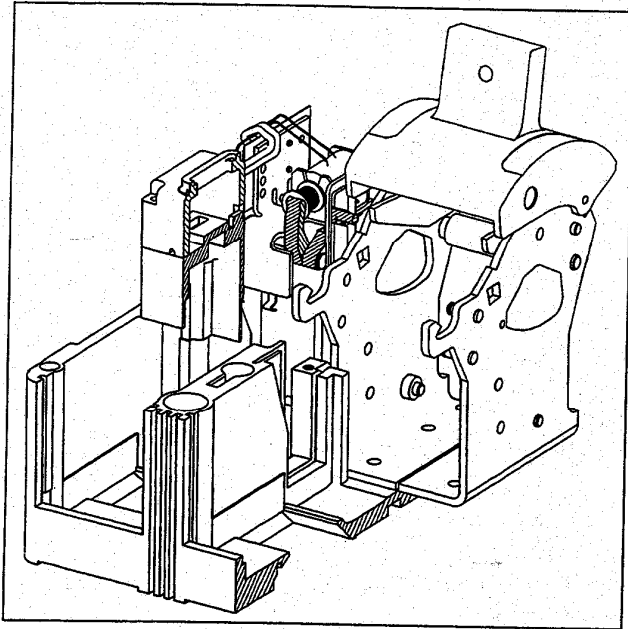

Fig. 2-3. UVR Installation

- d. If mechanical check does not trip circuit breaker, see if UVR and intermediate plunger are correctly installed. If UVR and intermediate plunger appear to be properly installed and problem persists, contact Cutler-Hammer.

**CAUTION**

WHEN INSTALLING CIRCUIT BREAKER MAIN COVER, MAKE SURE THAT ALL INTERNAL PARTS ARE IN PLACE:

- ALL LEADS ARE CLEAR OF THE COVER.

2-10. With circuit breaker handle in the TRIPPED position and accessory pigtail leads (if used) routed as required, install circuit breaker covers. Secure with pan-head screws. Torque to 22-24 lb-in. (2.49- 2.72 N.m).

2-11. Place accessory labels (supplied with kit) on circuit breaker (see Fig. 2-6).

2-12. Where practical and after taking all necessary safety precautions, apply rated voltage to UVR.

Reset and close circuit breaker. Confirm that circuit breaker trips when voltage is removed.

2-13. Install circuit breaker.

Note: Accessory labels show connection diagram for UVR contacts. Pigtail leads are color coded orange.

2-14. Connect UVR as required (see Fig. 2-7).

Cutler-Hammer assumes no responsibility for the malfunctioning of accessories installed improperly by the customer.

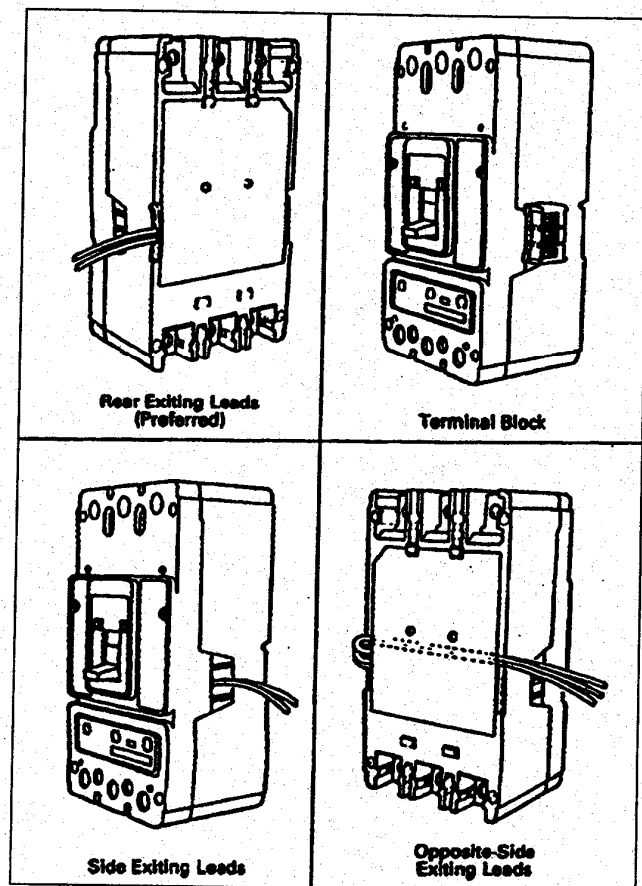

Fig. 2-4. Accessory Wiring Options

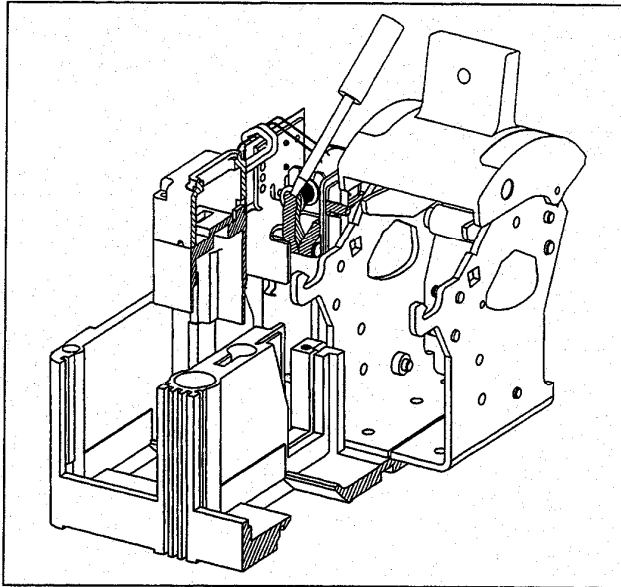

Fig. 2-5. Screwdriver Depressing Undervoltage Release's Solenoid Plunger

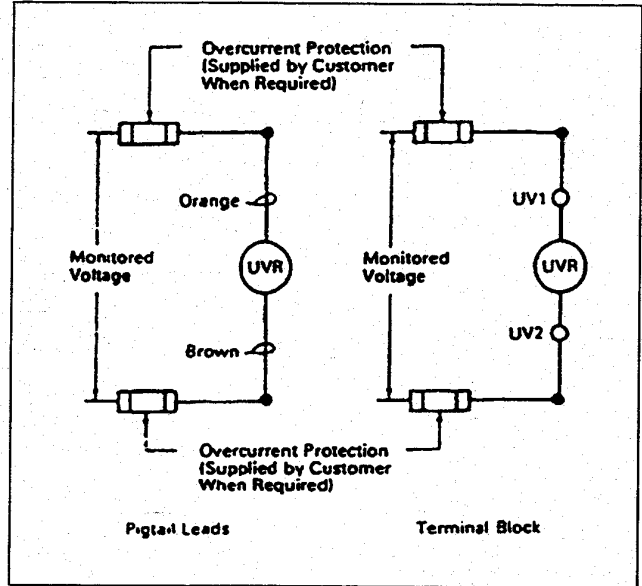

Fig. 2-7. Undervoltage Release Mechanism (Handle Reset) Connection Diagram

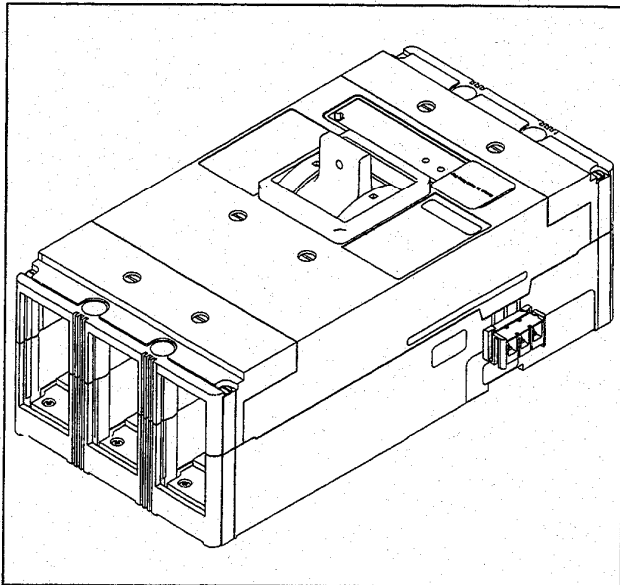

Fig. 2-6. Preferred Mounting Locations for Accessory Nameplate Labels

TABLE 1-1. AC (50/60 HZ) UNDERVOLTAGE RELEASE MECHANISM (HANDLE RESET) RATINGS^①

Catalog Suffix	Application Ratings		Electrical Operating Ratings				Approximate Operating Time (ms)			
	Voltage (V)	VA	Supply Voltage (V)	Dropout Voltage (V) Min. Max.	Pickup Voltage (V) Max.	Min ^② UVR Response	Initiation ^③ Circuit Breaker Contact Separation	Maximum Circuit Breaker Contact Opening	Dielectric ^④ Withstand Voltage (V)	
01	9	3.15	9	3.2 6.3	7.7	5	21	37	1018	
02	12	1.92	12	4.2 8.4	10.2	5	15	31	1024	
03	24	2.40	24	8.4 16.8	20.4	5	20	36	1048	
05	48-60	2.35	48	21 33.6	40.8	5	21	38	1120	
08	110-127	4.14	60			5				
		3.41	110	44.5 77	93.5	5	24	40	1500	
11	208-240	3.84	120							
		4.19	127							
		4.78	208	84 145.6	176.8	5	24	40	1500	
15	380-500	5.50	220							
		6.48	240							
		6.84	380	175 266	323	5	22	38	2500	
		8.30	415							
		9.24	440							
		11.00	480							
		12.00	500							

① Endurance - 400 electrical operations plus 5600 mechanical operations.

② UVR will override a momentary voltage dip up to the response time shown.

③ Unlatching occurs six milliseconds before circuit breaker contacts begin to separate.

④ For one minute.

TABLE 1-2. DC UNDERVOLTAGE RELEASE MECHANISM (HANDLE RESET) RATINGS^①

Catalog Suffix	Application Ratings		Electrical Operating Ratings				Approximate Operating Time (ms)			
	Voltage (V)	VA	Supply Voltage (V)	Dropout Voltage (V) Min. Max.	Pickup Voltage (V) Max.	Min ^② UVR Response	Initiation ^③ Circuit Breaker Contact Separation	Maximum Circuit Breaker Contact Opening	Dielectric ^④ Withstand Voltage (V)	
20	12	2.64	12	4.2	8.4	10.2	5	20	36	1024
21	24	3.60	24	8.4	16.8	20.4	5	23	39	1048
23	48-60	3.64	48	21	33.6	40.8	5	30	46	1120
		5.46	60					13		
26	110-125	2.86	110	44.5	77	93.5	6	21	37	1500
		3.36	120							
		3.63	125							
28	220-250	4.84	220	87.5	154	187	Inst.	21	37	1500
		6.25	250					10		

- ① Endurance - 400 electrical operations plus 5600 mechanical operations.
- ② UVR will override a momentary voltage dip up to the response time shown.
- ③ Unlatching occurs six milliseconds before circuit breaker contacts begin to separate.
- ④ For one minute.

Cutler-Hammer

Pittsburgh, Pennsylvania U.S.A.

Style No. 6634C84H02 Effective December 1997
Printed in U.S.A./CCI

