



# Installation Instructions for Low Energy Shunt Trip for NDB, ND, NDC, HND, NW, HNW, NWC Circuit Breakers, Series C Molded Case Switches, and Motor Circuit Protectors (HMCP)



## WARNING

**CONTACT WITH ENERGIZED EQUIPMENT CAN RESULT IN DEATH, SEVERE PERSONAL INJURY, OR SUBSTANTIAL PROPERTY DAMAGE. DO NOT ATTEMPT TO INSTALL OR PERFORM MAINTENANCE ON EQUIPMENT WHILE IT IS ENERGIZED. ALWAYS VERIFY THAT NO VOLTAGE IS PRESENT BEFORE PROCEEDING WITH THE TASK, AND ALWAYS FOLLOW GENERALLY ACCEPTED SAFETY PROCEDURES.**

**THE CUTLER-HAMMER CORPORATION IS NOT LIABLE FOR THE MISAPPLICATION OR MISINSTALLATION OF ITS PRODUCTS.**

The user is cautioned to observe all recommendations, warnings and cautions relating to the safety of personnel and equipment well as as general and local health and safety laws, codes and procedures.

The recommendations and information contained herein are based on Cutler-Hammer experience and judgment, but should not be considered to be all-inclusive or covering every application or circumstance which may arise. If any questions arise, contact Cutler-Hammer for further information or instructions.

## 1-0 INTRODUCTION

### General Information

The low energy shunt trip (LEST) is designed to interface with a customer ground fault detection system (Figure 1-1). The LEST consists of an intermittent rated solenoid with a plunger and a reset lever assembled to a plug-in module. The plug-in module is mounted in slots in the top of the trip unit and occupies the accessory cavity in the circuit breaker frame. The reset lever resets the LEST when the trip signal is removed and the circuit breaker handle is moved to the reset (extreme OFF) position.

The LEST is designed to trip the circuit breaker when a 100 microfarad capacitor charged to 28 Vdc is discharged through the solenoid.

For this publication, the term circuit breaker shall also include molded case switch and motor circuit protector.

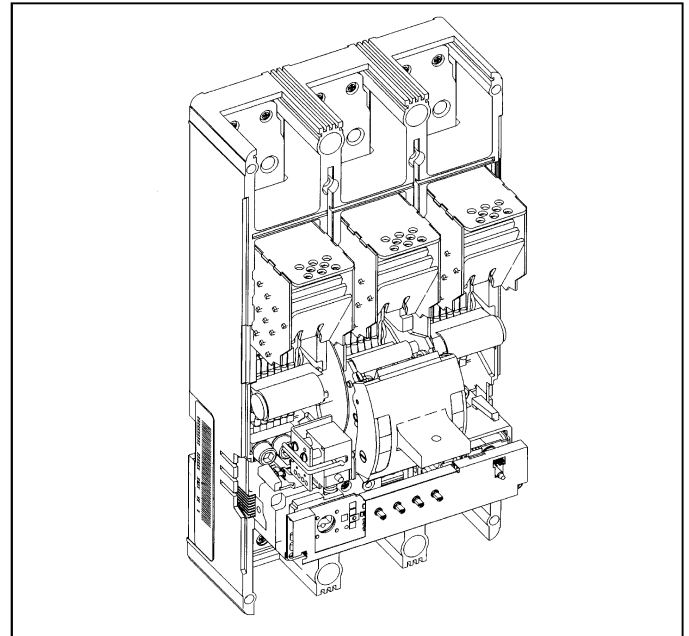

Figure 1-1 Low Energy Shunt Trip Installed in N-Frame Circuit Breaker.

Depending on the model ordered, connections for the LEST are in one of four forms. The standard wiring configuration is pigtail leads exiting the rear of the base directly behind the LEST. Optional configurations include a terminal block mounted on the same side of the base as the accessory, leads exiting the side of the base where the accessory is mounted, and leads exiting rear of the base on the side opposite the accessory. The 18-inch long pigtail leads are color coded for identification; identification labels are provided for pigtail leads and terminal block points. For allowable locations of all accessories, refer to Frame Book 29-104.

## NOTICE

**When the walking beam interlock is used with the circuit breaker, the rear trough cannot be used for accessory pigtail leads.**

This instruction leaflet (IL) gives detailed procedures for installing the LEST.

## 2-0 INSTALLATION

**NOTICE**

The LEST can be field-installed in ND, HND, NDC and CNDC circuit breakers under UL File E64983.

The LEST can be field-installed in NW, HNW, and NWC circuit breakers.

The LEST is listed for factory installation under UL File E7819.

Where local codes and standards permit and UL listing is not required, internal accessories can be field installed in sealed circuit breakers. In this case, UL listing becomes invalid and the label should be removed.

Before attempting to install the LEST, check that the catalog number is correct as ordered and that the rating of the accessory satisfies job requirements.

The LEST, Shown in kit form in Figure 2-1, is installed in the right or left accessory mounting cavity of a 2-, 3-, or 4-pole circuit breaker, and in the left pole only of a circuit breaker with an NS (electronic) trip unit. A LEST must be installed in the circuit breaker before the circuit breaker is mounted in an electrical system. To install the LEST, perform the following procedures:

**NOTICE**

A circuit breaker that is mounted in an electrical system must be removed to install the accessory. To ensure correct accessory installation, the circuit breaker must be placed on a horizontal surface.

**WARNING**

**THE VOLTAGES IN ENERGIZED EQUIPMENT CAN CAUSE DEATH OR SEVERE PERSONAL INJURY. BEFORE REMOVING A CIRCUIT BREAKER INSTALLED IN AN ELECTRICAL SYSTEM, MAKE SURE THE CIRCUIT BREAKER IS SWITCHED TO THE OFF POSITION AND THERE IS NO VOLTAGE PRESENT WHERE WORK IS TO BE PERFORMED. SPECIAL ATTENTION SHOULD BE PAID TO REVERSE FEED APPLICATIONS TO ENSURE NO VOLTAGE IS PRESENT.**

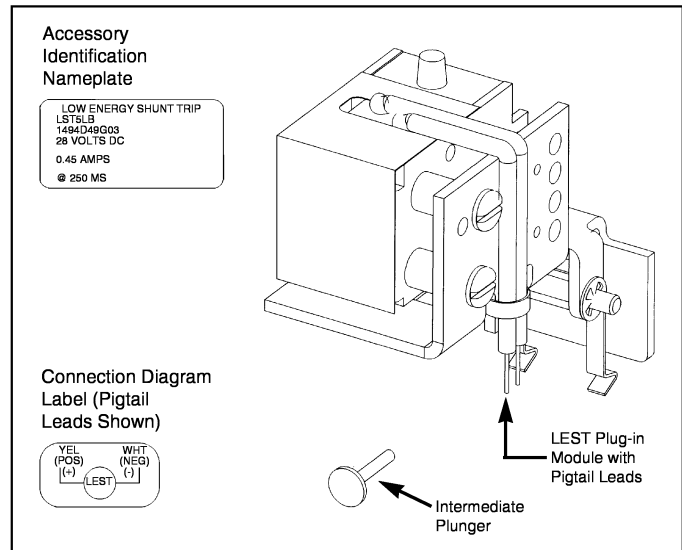

Figure 2-1 Low Energy Shunt Trip Kit

**NOTICE**

**For new circuit breaker installation, the trip unit must be installed in circuit breaker before attempting to install a LEST.**

- 2-1. Switch circuit breaker to OFF position.

**NOTICE**

**To install LEST, circuit breaker operating mechanism must be in tripped position.**

**Molded case switch trip units are not equipped with a Push-to-Trip button. For molded case switches, omit step 2-3.**

- 2-2. Disconnect and remove circuit breaker from installation and terminal connections.
- 2-3. Press PUSH-TO-TRIP button to trip operating mechanism and check handle moves to trip position with white colored indicator visible in escutcheon window.
- 2-4. Remove cover screws and cover.

- 2-5. Push intermediate plunger supplied with LEST in one hole to trip the molded case switch. Remove plunger to prevent it falling out of recessed hole in trip unit and into molded case switch mechanism.
- 2-6. Remove interphase barrier between center pole and pole in which accessory is to be mounted and flip (Figure 2-2).
- 2-7. Install LEST as described in the following steps (Figure 2-3):



**CAUTION**

**IF LEST IS REMOVED FROM CIRCUIT BREAKER, INTERMEDIATE PLUNGER MUST ALSO BE REMOVED. FAILURE TO REMOVE THE INTERMEDIATE PLUNGER CAN RESULT IN EQUIPMENT DAMAGE.**

- a. Remove barrier from trip unit accessory mounting slots in pole being used for accessory (see Figure 2-3).
- b. Position intermediate plunger in trip unit (Figure 2-3).
- c. Press intermediate plunger into recess in trip unit, and hold in position. Slide LEST plug-in module into slots (Figure 2-3) until retaining clip snaps into trip unit. For terminal block assemblies, slide terminal block into mounting slot on side of base as plug-in module is properly positioned.



**CAUTION**

**LEADS SHOULD BE FORMED AND ROUTED TO CLEAR ALL MOVING PARTS WHEN ACCESSORY IS PROPERLY INSTALLED. PIGTAIL WIRES COULD BE DAMAGED IF IN CONTACT WITH MOVING PARTS.**

**NOTICE**

**For a LEST having rear or opposite-side exiting pigtail leads, thread leads through center trough in side of base before attempting to insert the mounting bracket. Pigtail leads exiting in this manner should be eased through trough as mounting bracket is**

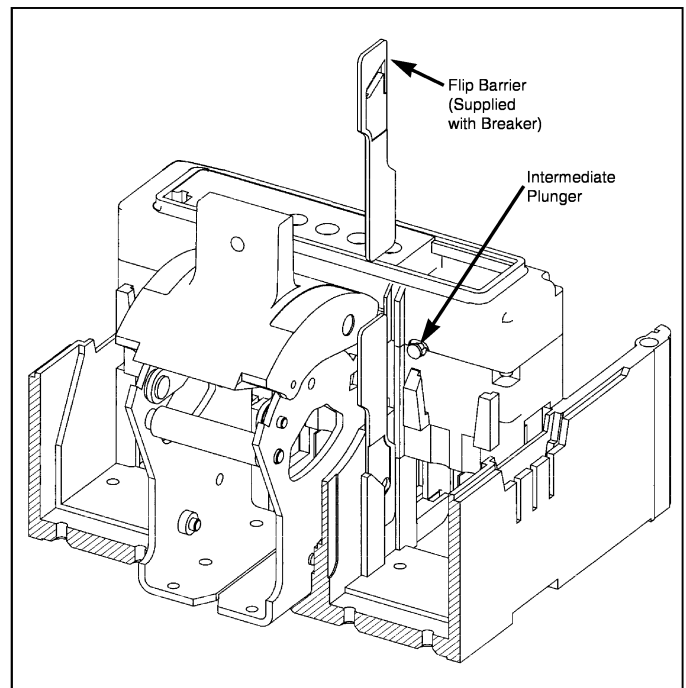

*Figure 2-2 Interphase Barrier Replacement and Intermediate Plunger Positioning*

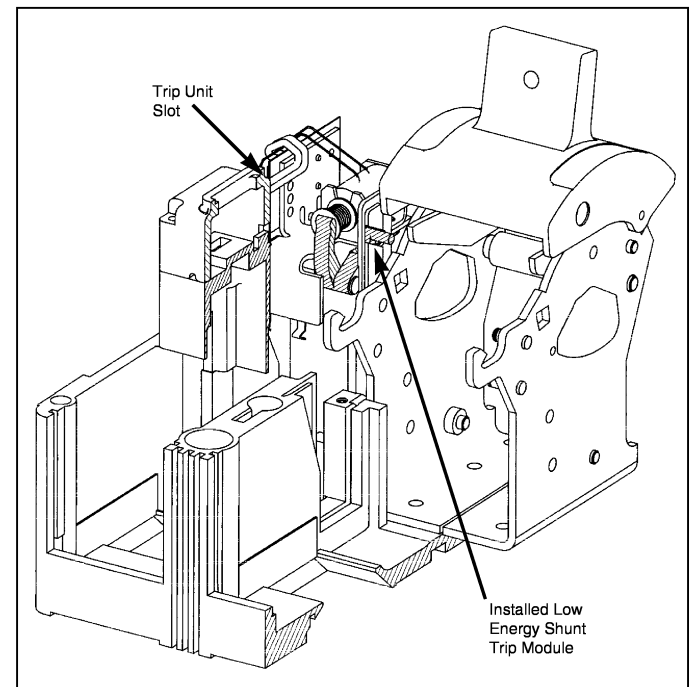

*Figure 2-3 Installing Intermediate Plunger and Shunt Trip*

inserted into trip unit retaining slots. Use center trough also for leads exiting the side of the circuit breaker.

- 2-8. Route wiring to meet installation requirements (Figure 2-4). If required, complete routing of leads to opposite side through rear window trough.



## WARNING

**CONTACT WITH MOVING PARTS CAN CAUSE PERSONAL INJURY. WHEN CHECKING ACCESSORY, DO NOT PUT FINGERS NEAR MOVING PARTS INSIDE CIRCUIT BREAKER CASE. SPRINGS CAUSE INTERNAL PARTS TO MOVE QUICKLY AND WITH FORCE.**

- 2-9. Perform mechanical check of LEST after installation:
- With the circuit breaker still electrically isolated, reset the circuit breaker.



## CAUTION

**THE SOLENOID PLUNGER IS HELD IN THE SEATED POSITION BY A PERMANENT MAGNET. LIGHT PRESSURE, NOT TO EXCEED TOW POUNDS, SHOULD BE USED TO MOVE PLUNGER FROM SEATED POSITION.**

- Position a small flat-blade screwdriver (Figure 2-5) under the head of the solenoid plunger. Pry the plunger free from the seated position and check the circuit breaker trips.
- Reset circuit breaker handle and check that handle arm moves the reset lever, and that solenoid plunger is pushed into solenoid and held by magnet.
- If mechanical check does not trip circuit breaker, see if LEST and intermediate plunger are correctly installed. If LEST and intermediate plunger appear to be properly installed and problem persists, contact Cutler-Hammer.

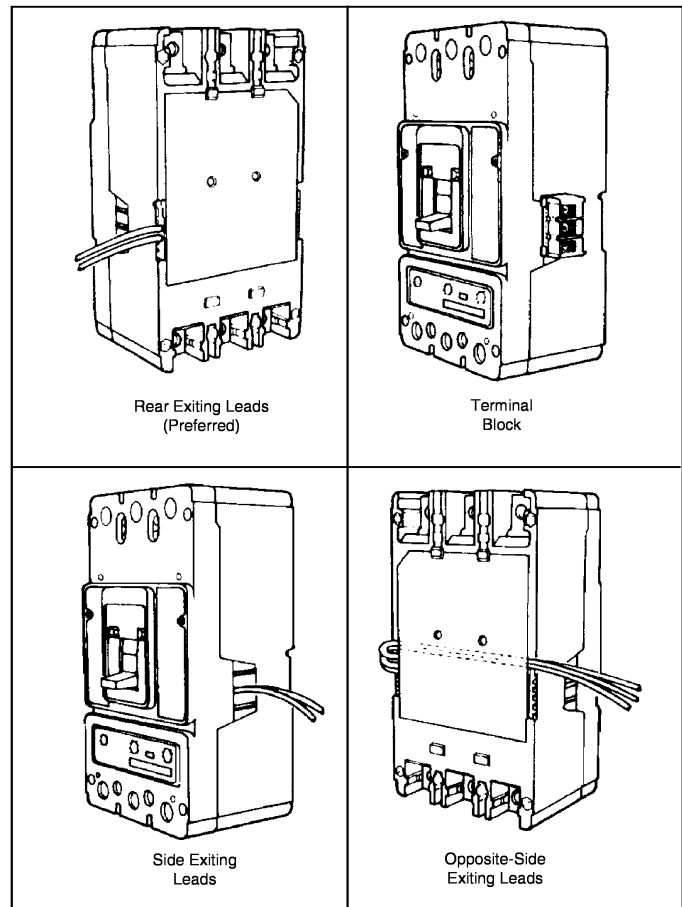

Figure 2-4 Accessory Wiring Options

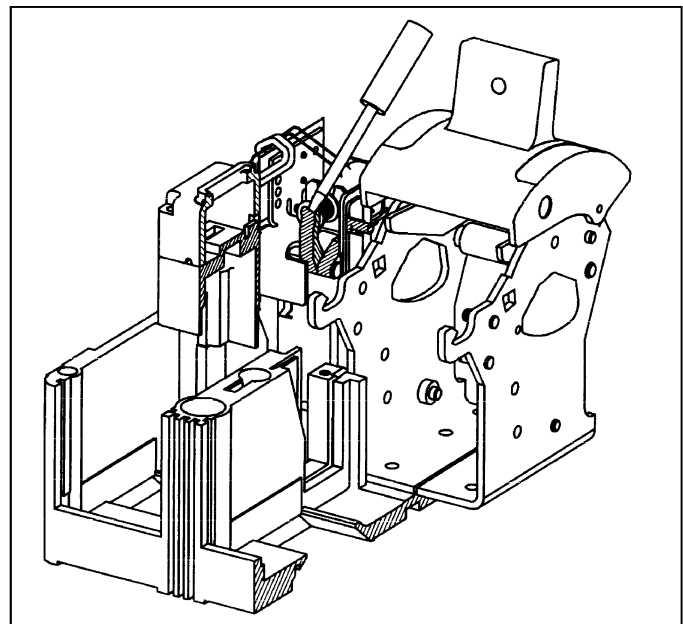

Figure 2-5 Testing Operation of Solenoid Plunger



**CAUTION**

**WHEN INSTALLING CIRCUIT BREAKER MAIN COVER, MAKE SURE THAT ALL INTERNAL PARTS ARE IN PLACE:**

- **SLIDING HANDLE BARRIER IS POSITIONED SO THAT THE HANDLE OPENING IS ALIGNED WITH THE HANDLE.**

- **ALL LEADS ARE CLEAR OF THE COVER**

2-10. With circuit breaker handle in TRIPPED position and accessory pigtail leads (if used) routed as required, install circuit breaker covers. Secure with pan-head screws. Torque to 22-24 lb-in (2.49-2.72 N.m.).

2-11. Remove and discard UL listing label on NDB circuit breakers only.

2-12. Place accessory labels (supplied with kit) on circuit breaker (See Figure 2-6).

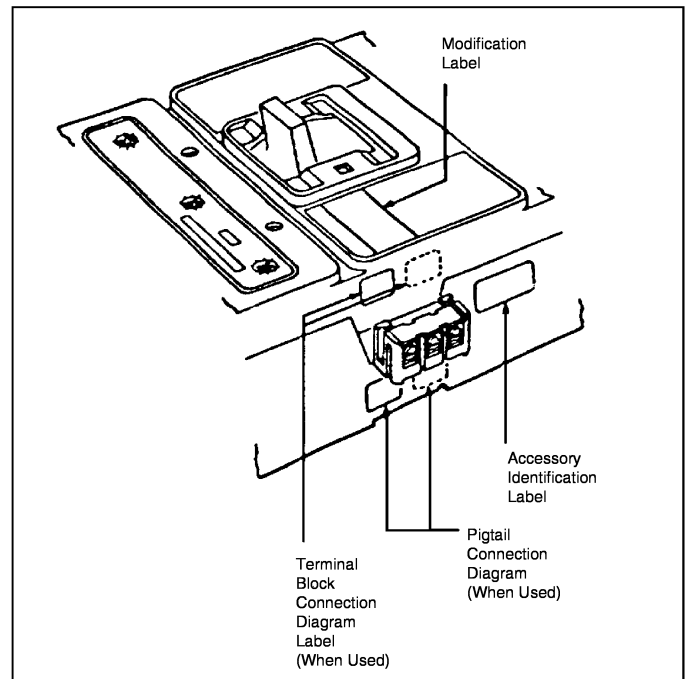

Figure 2-6 Preferred Mounting Locations for Accessory Nameplate Labels



**CAUTION**

**SOLENOID IS RATED FOR INTERMITTENT DUTY. CONTINUOUS APPLICATION OF 24 VDC WILL DAMAGE THE SOLENOID.**

2-13. Electrical check. Where practical and after taking all necessary safety precautions, connect yellow LEST lead to positive terminal of a DC power supply and white lead to ground. Reset and close circuit breaker. Confirm that circuit breaker trips when 24 Vdc (maximum pulse of one second) is applied to leads.

2-14. Install circuit breaker.

**NOTICE**

**Accessory labels show connection diagram for LEST contacts. Pigtail leads are color coded white and yellow.**

2-15. Connect LEST to ground fault detection circuit to be monitored (Figure 2-7). Yellow lead is positive.

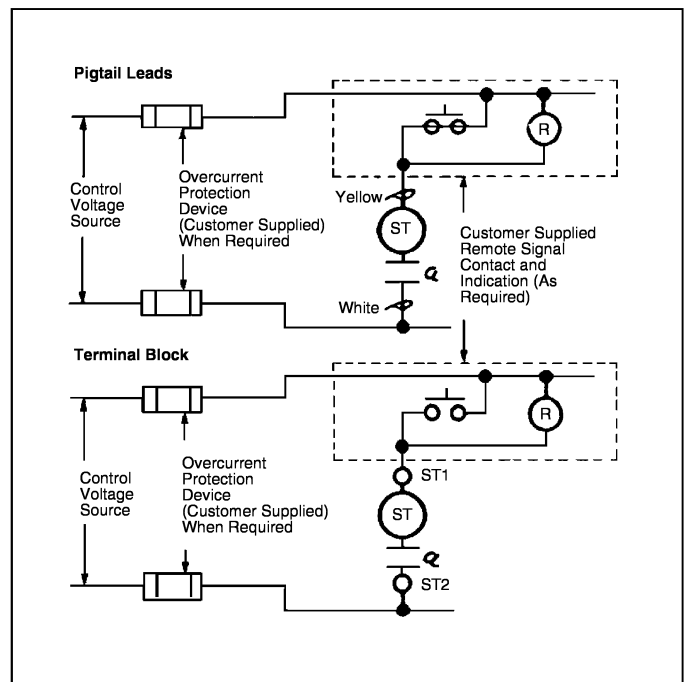

Figure 2-7 Low Energy Shunt Trip Connection Diagram

Cutler-Hammer assumes no responsibility for malfunctioning accessories installed improperly by the customer.





**Cutler-Hammer**

Pittsburgh, PA 15220

Effective 7/98 (ISI)

Style 6634C83H03

Printed in U.S.A.

