

Installation Instructions for Auxiliary Switch for NDB, ND, HND, NDC, NW, HNW, NWC Circuit Breakers, Series C Molded Case Switches, and Motor Circuit Protectors (HMCP)

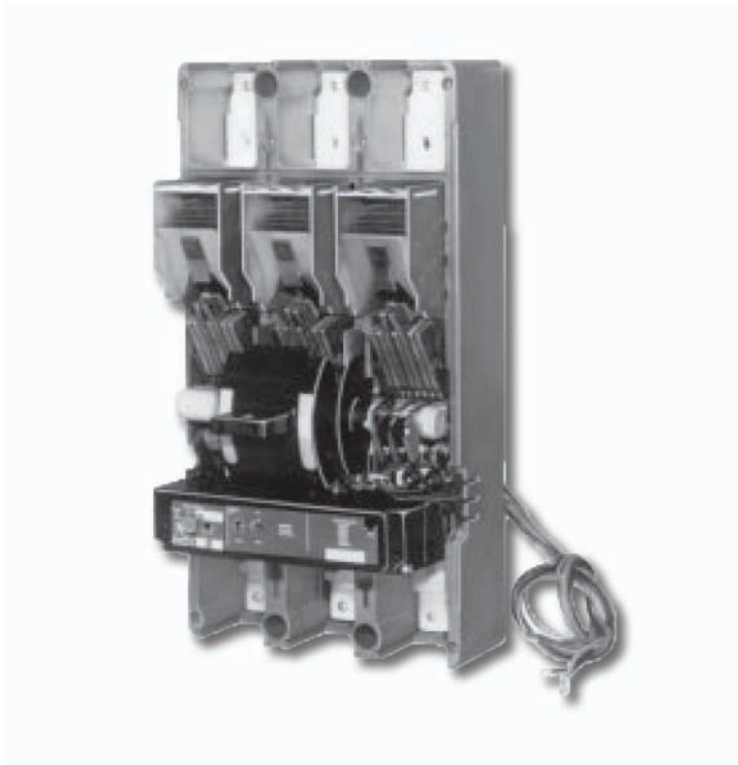

Contents

Description	Page
1. Introduction	2
2. Installation	3



Powering Business Worldwide



WARNING

CONTACT WITH ENERGIZED EQUIPMENT CAN RESULT IN DEATH, SEVERE PERSONAL INJURY, OR SUBSTANTIAL PROPERTY DAMAGE. DO NOT ATTEMPT TO INSTALL OR PERFORM MAINTENANCE ON EQUIPMENT WHILE IT IS ENERGIZED. ALWAYS VERIFY THAT NO VOLTAGE IS PRESENT BEFORE PROCEEDING WITH THE TASK, AND ALWAYS FOLLOW GENERALLY ACCEPTED SAFETY PROCEDURES.

EATON IS NOT LIABLE FOR THE MISAPPLICATION OR MISINSTALLATION OF ITS PRODUCTS.

The user is cautioned to observe all recommendations, warnings, and cautions relating to the safety of personnel and equipment as well as all general and local health and safety laws, codes, and procedures.



Figure 1-1 Auxiliary Switch Installed in N-Frame Circuit Breaker.

The recommendations and information contained herein are based on Eaton experience and judgement, but should not be considered to be all-inclusive or covering every application or circumstance which may arise. If any questions arise, contact Eaton for further information or instructions.

1. INTRODUCTION

General Information

The auxiliary switch (Fig.1 -1) indicates circuit breaker contacts status, and is used for remote signaling and system interlocking purposes. The switch consists of one, two, or three single pole, double-throw (SPDT) switches assembled to a plug-in module. The plug-in module is mounted in slots in the top of the trip unit; it occupies the accessory cavity in the circuit breaker frame, and is positioned so that the switch actuator is operated by the crossbar. Each SPDT switch has one "a" and one "b" contact. When the crossbar is in the contacts-closed position, the "a" contact of each SPDT switch is closed and the "b" contact is open. When the crossbar is in the tripped or contacts-open position, the "a" contact is open and the "b" contact is closed.

Table 1-1 lists electrical rating data for the auxiliary switch.

For this publication, the term circuit breaker shall also include molded case switch and motor circuit protector.

Table 1-1. Auxiliary Switch Electrical Rating Data ①②③

Maximum Voltage (V)	Freq.	Maximum Current (A)	Dielectric Withstand Voltage (V)
600	50/60 Hz	6	2500
125	DC	0.5④	
250	DC	0.25④	

① Endurance - 400 electrical operations plus 5600 mechanical operations

② Pigtail wire size - No. 18 AWG (0.82 mm(-))

③ Terminal block is listed for use with one or two No. 18 to No. 14 AWG solid or stranded copper wires. Torque is 7 lb-in (0.8 N.m)

④ Non-inductive load

Depending on the model ordered, connections for the auxiliary switch are in one of four forms. The standard wiring configuration is pigtail leads exiting the rear of the base directly behind the auxiliary switch. Optional configurations include a terminal block mounted on the same side of the base as the accessory, leads exiting the side of the base where the accessory is mounted, and leads exiting the rear of the base on the side opposite the accessory. The 18-inch long pigtail leads are color coded for identification; identification labels are provided for pigtail leads and terminal block points. For allowable locations of all accessories, refer to Selection Data 29-120N. See Fig. 2-2.

This instruction leaflet (I.L.) gives detailed procedures for installing the auxiliary switch.

2. INSTALLATION

NOTICE

The auxiliary switch can be field-installed in ND, HND, and NDC circuit breakers under UL File E64983.

The auxiliary switch can be field-installed in NW, HNW, and NWC circuit breakers.

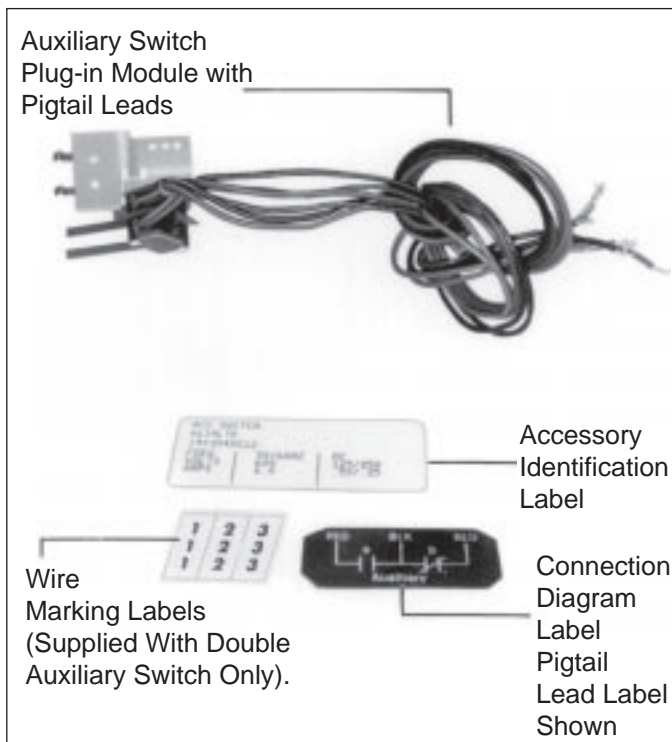

Figure 2-1 Auxiliary Switch Kit.

The auxiliary switch is listed for factory installation under UL File E7819.

For sealed circuit breakers (NDB), Underwriters Laboratories Inc. UL 489 requires that internal accessories be installed at the factory. The auxiliary switch is listed for factory installation under UL File E7819.

Where local codes and standards permit and UL listing is not required, internal accessories can be field installed in sealed circuit breakers. In this case, UL listing becomes invalid and the label should be removed .

Before attempting to install the auxiliary switch check that the catalog number is correct as ordered and that the rating of the accessory satisfies the job requirements.

The auxiliary switch, shown in kit form in Fig. 2-1, is installed in the right or left accessory mounting cavity of a 2-, 3-, or 4 pole circuit breaker. An auxiliary switch must be installed in the circuit breaker before the circuit breaker is mounted in an electrical system. To install the auxiliary switch, perform the following procedures:

NOTICE

A circuit breaker that is mounted in an electrical system must be removed to install the accessory. To ensure correct accessory installation, the circuit breaker must be placed on a horizontal surface.



WARNING

THE VOLTAGES IN ENERGIZED EQUIPMENT CAN CAUSE DEATH OR SEVERE PERSONAL INJURY. BEFORE REMOVING A CIRCUIT BREAKER INSTALLED IN AN ELECTRICAL SYSTEM, MAKE SURE THE CIRCUIT BREAKER IS SWITCHED TO THE OFF POSITION AND THERE IS NO VOLTAGE PRESENT WHERE WORK IS TO BE PERFORMED. SPECIAL ATTENTION SHOULD BE PAID TO REVERSE FEED APPLICATIONS TO ENSURE NO VOLTAGE IS PRESENT.

NOTICE

For new circuit breaker installation, the trip unit must be installed in circuit breaker before attempting to install an auxiliary switch.

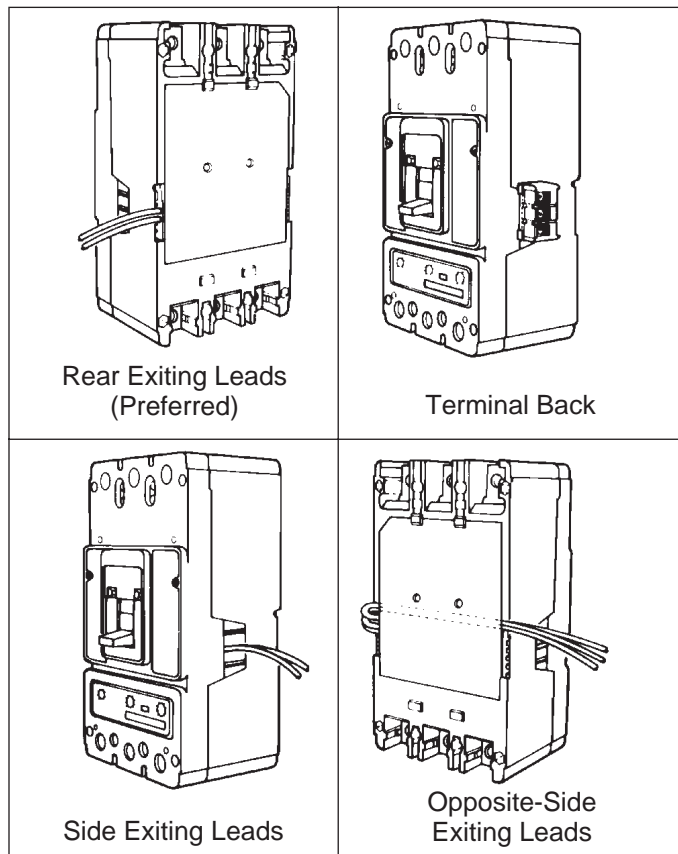

Figure 2-2 Accessory Wiring Options.

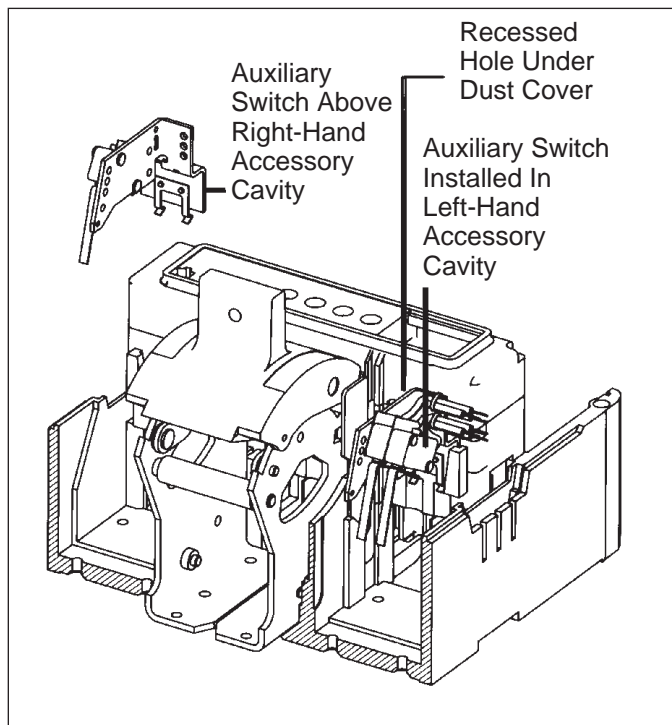

Figure 2-3 Auxiliary Switch Installation Positions.

2-1. Switch circuit breaker to OFF position.

NOTICE

Molded case switch trip units are not equipped with a PUSH-TO-TRIP button. For molded case switches, omit step 2-3.

2-2. Disconnect and remove circuit breaker from installation and terminal connections.

2-3. Switch circuit breaker to ON position then press PUSH TO-TRIP button to trip operating mechanism and check handle moves to trip position with white colored indicator visible in escutcheon window.

2-4. Remove circuit breaker cover screws and covers.

2-5. For high instantaneous trip-types (catalog suffix K designations) molded case switches, find recessed hole in left pole of the trip unit normally intended for intermediate plunger, remove dust cover (Fig. 2-3) and push a fine point implement in hole to trip the molded case switch.

NOTICE

For a single auxiliary switch having rear or opposite-side exiting pigtail leads, thread leads through center trough in side of base before attempting to insert the mounting bracket. For double or triple accessories, leads from the outer auxiliary switch must go to the center trough. Pigtail leads exiting in this manner should be eased through trough as mounting bracket is inserted into trip unit retaining slots. Use center trough also for leads exiting the side of the circuit breaker.

2-6. Route wiring to meet installation requirements (see Fig. 2-2).



CAUTION

LEADS SHOULD BE FORMED AND ROUTED TO CLEAR ALL MOVING PARTS WHEN ACCESSORY IS PROPERLY INSTALLED. LEADS COULD BE DAMAGED IF IN CONTACT WITH MOVING PARTS.

2-7. Insert auxiliary switch as described in the following steps (Fig. 2-3).

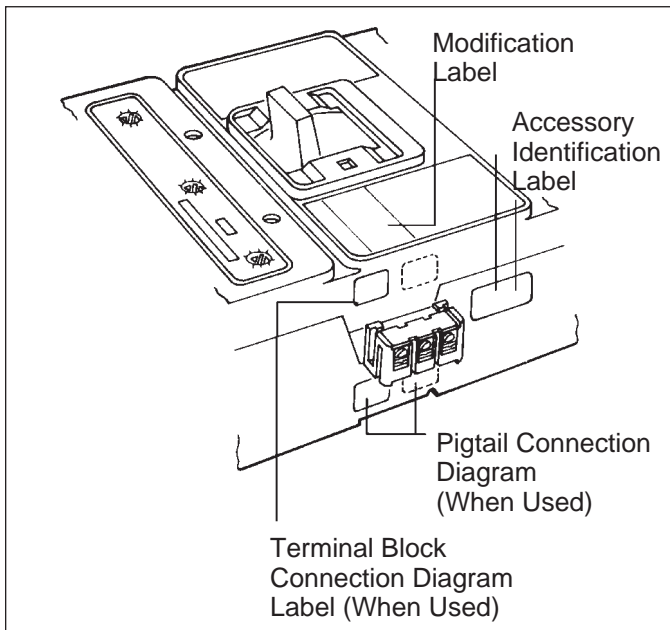

Figure 2-4 Preferred Mounting Locations for Accessory Nameplate Labels.

- a. Slide auxiliary switch plug-in module into slots until retaining spring clip snaps into trip unit. Auxiliary switch actuator must be in front of the crossbar. For terminal block assemblies, slide terminal block into mounting slot on side of base as plug-in module is being positioned.
- b. If required, complete routing of leads to opposite side through rear wiring trough.
- c. For double or triple auxiliary switch pigtail leads, attach wire marking labels to bundle of three leads for each switch. (Markers designated 1, 2, and 3 are provided if required.)



CAUTION

WHEN INSTALLING CIRCUIT BREAKER MAIN COVER, MAKE SURE THAT ALL INTERNAL PARTS ARE IN PLACE:

- All leads are clear of the cover.

2-8. With circuit breaker handle in TRIPPED position and accessory pigtail leads (if used) routed as required, install circuit breaker covers. Secure with pan-head screws. Torque to 22-24 lb-in (2.49- 2.72 N.m).

2-9. Place accessory labels (supplied with kit) on circuit breaker (see Fig. 2-4).

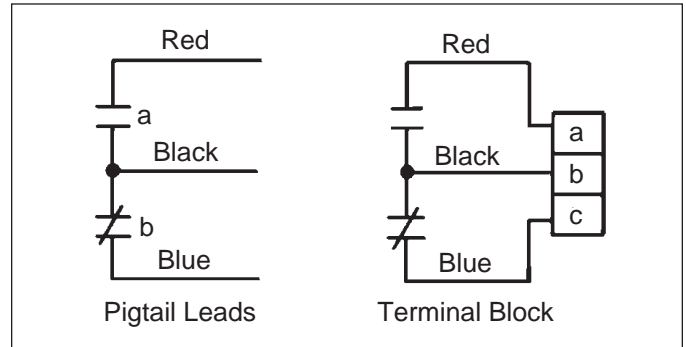

Figure 2-5 Auxiliary Switch Connection Diagram.

NOTICE

Accessory labels show connection diagram for auxiliary switch. Pigtail leads are color coded red, black, and blue.

2-10. Test auxiliary switch(es). Connect continuity tester or ohmmeter across pigtail leads or terminal block connections. Check continuity as follows:

- a. Circuit breaker handle OFF
"a" contact(s) - open
"b" contact(s) - closed.
- b. Circuit breaker handle ON
"a" contact(s) - closed
"b" contact(s) - open

NOTICE

For molded case switches omit step c.

- c. Press PUSH-TO-TRIP button
"a" contact(s) - open
"b" contact(s) - closed.

If auxiliary switch(es) fails test, make sure that auxiliary switch(es) module is properly seated in trip unit slots. If auxiliary switch(es) appears to be correctly installed and the problem persists, contact Eaton.

2-11. Install circuit breaker.

2-12. Connect auxiliary switch(es) as required (see Fig. 2-5).

Eaton assumes no responsibility for malfunctioning accessories installed improperly by the customer.

Notes:

Notes:

The instructions for installation, testing, maintenance, or repair herein are provided for the use of the product in general commercial applications and may not be appropriate for use in nuclear applications. Additional instructions may be available upon specific request to replace, amend, or supplement these instructions to qualify them for use with the product in safety-related applications in a nuclear facility.

This Instruction Booklet is published solely for information purposes and should not be considered all-inclusive. If further information is required, you should consult an authorized Eaton sales representative.

The sale of the product shown in this literature is subject to the terms and conditions outlined in appropriate Eaton selling policies or other contractual agreement between the parties. This literature is not intended to and does not enlarge or add to any such contract. The sole source governing the rights and remedies of any purchaser of this equipment is the contract between the purchaser and Eaton.

NO WARRANTIES, EXPRESSED OR IMPLIED, INCLUDING WARRANTIES OF FITNESS FOR A PARTICULAR PURPOSE OR MERCHANTABILITY, OR WARRANTIES ARISING FROM COURSE OF DEALING OR USAGE OF TRADE, ARE MADE REGARDING THE INFORMATION, RECOMMENDATIONS, AND DESCRIPTIONS CONTAINED HEREIN.

In no event will Eaton be responsible to the purchaser or user in contract, in tort (including negligence), strict liability or otherwise for any special, indirect, incidental or consequential damage or loss whatsoever, including but not limited to damage or loss of use of equipment, plant or power system, cost of capital, loss of power, additional expenses in the use of existing power facilities, or claims against the purchaser or user by its customers resulting from the use of the information, recommendations and description contained herein.

Eaton Corporation
Electrical Sector
1111 Superior Ave.
Cleveland, OH 44114
United States
877-ETN-CARE (877-386-2273)
Eaton.com

© 2011 Eaton Corporation
All Rights Reserved
Printed in USA
Publication No. IL29C124D / TBG000807
Part No. 6634C81H04
December 2011