



### INTERPHASE BARRIER KIT

Cutler-Hammer

Cat. No. 1PB4  
Style No. 4214B16G01  
Quantity - 1

**Circuit Breaker  
Accessory**

**For L-Frame  
& MDL Frame**

Cutler-Hammer Business  
Pittsburgh, PA.

6633 C97 H04

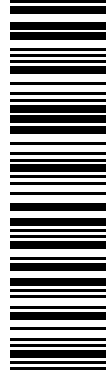
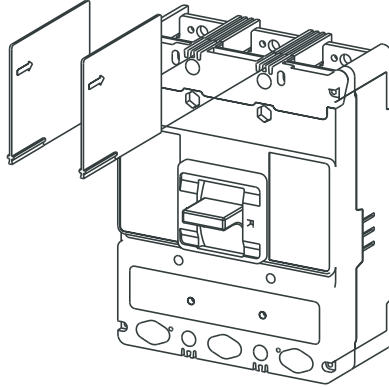

1 07 82113 76107 4

**Package of 2 Barriers**

**Barriers May Be Assembled To Either Line End or Load End**

**Instructions For Assembly  
Slide Barriers Into Creepage Grooves of Circuit Breaker.**



### INTERPHASE BARRIER KIT

Cutler-Hammer

Cat. No. 1PB4  
Style No. 4214B16G01  
Quantity - 1

**Circuit Breaker  
Accessory**

**For L-Frame  
& MDL Frame**

Cutler-Hammer Business  
Pittsburgh, PA.

6633 C97 H04

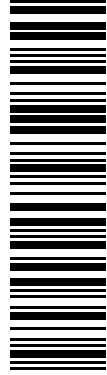
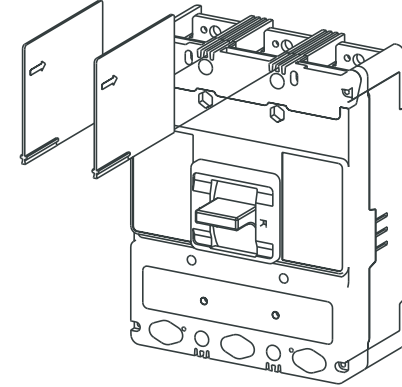

1 07 82113 76107 4

**Package of 2 Barriers**

**Barriers May Be Assembled To Either Line End or Load End**

**Instructions For Assembly  
Slide Barriers Into Creepage Grooves of Circuit Breaker.**

6633C97H04 - ECN # LD-6616



### INTERPHASE BARRIER KIT

Cutler-Hammer

Cat. No. 1PB4  
Style No. 4214B16G01  
Quantity - 1

**Circuit Breaker  
Accessory**

**For L-Frame  
& MDL Frame**

Cutler-Hammer Business  
Pittsburgh, PA.

6633 C97 H04

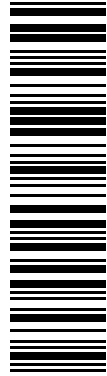
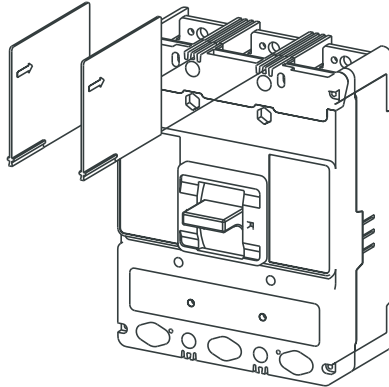

1 07 82113 76107 4

**Package of 2 Barriers**

**Barriers May Be Assembled To Either Line End or Load End**

**Instructions For Assembly  
Slide Barriers Into Creepage Grooves of Circuit Breaker.**



### INTERPHASE BARRIER KIT

Cutler-Hammer

Cat. No. 1PB4  
Style No. 4214B16G01  
Quantity - 1

**Circuit Breaker  
Accessory**

**For L-Frame  
& MDL Frame**

Cutler-Hammer Business  
Pittsburgh, PA.

6633 C97 H04

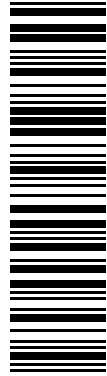
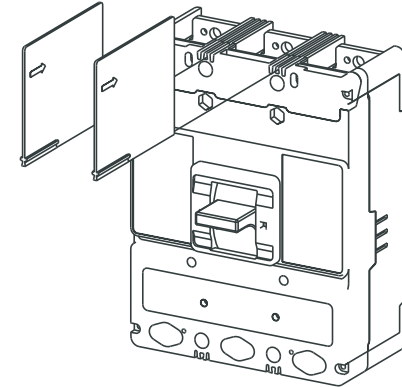

1 07 82113 76107 4

**Package of 2 Barriers**

**Barriers May Be Assembled To Either Line End or Load End**

**Instructions For Assembly  
Slide Barriers Into Creepage Grooves of Circuit Breaker.**

## INTERPHASE BARRIER KIT

Style No. - 4214B16G10

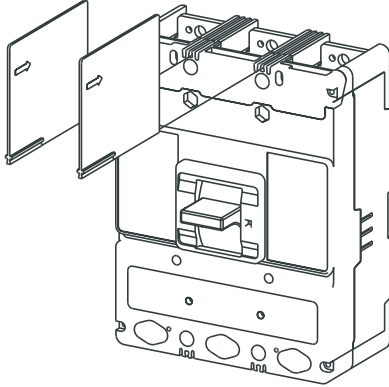

**Package of 2 Barriers**

**Barriers May Be Assembled To Either Line End or Load End**

**Instructions For Assembly**  
**Slide Barriers Into Creepage Grooves of Circuit Breaker.**

6633 C97 H05

6633C97H05 - ECN # LD-6736

## INTERPHASE BARRIER KIT

Style No. - 4214B16G10

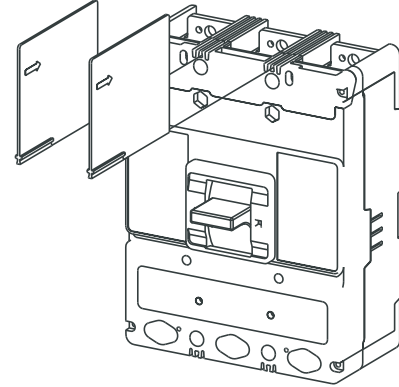

**Package of 2 Barriers**

**Barriers May Be Assembled To Either Line End or Load End**

**Instructions For Assembly**  
**Slide Barriers Into Creepage Grooves of Circuit Breaker.**

6633 C97 H05

## INTERPHASE BARRIER KIT

Style No. - 4214B16G10

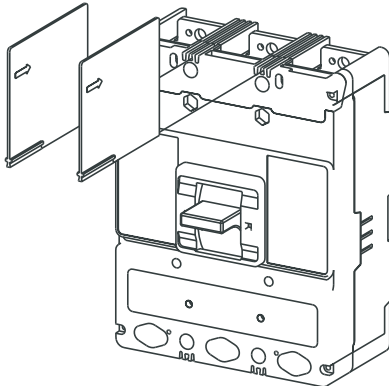

**Package of 2 Barriers**

**Barriers May Be Assembled To Either Line End or Load End**

**Instructions For Assembly**  
**Slide Barriers Into Creepage Grooves of Circuit Breaker.**

6633 C97 H05

## INTERPHASE BARRIER KIT

Style No. - 4214B16G10

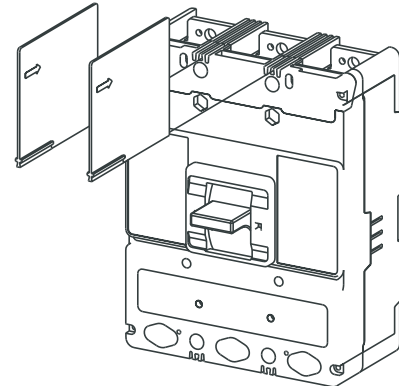

**Package of 2 Barriers**

**Barriers May Be Assembled To Either Line End or Load End**

**Instructions For Assembly**  
**Slide Barriers Into Creepage Grooves of Circuit Breaker.**

6633 C97 H05



**INTERPHASE BARRIER**  
For 140U-M/Q Breaker  
Cat. No. - 140U-M-PB A  
Quantity - 1

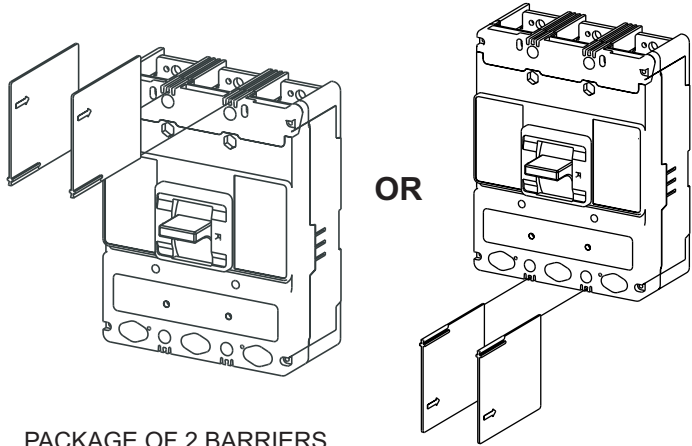

OR



1 06 11320 84492 1

PACKAGE OF 2 BARRIERS

6633C97H06 - ECN # LD-6616



**INTERPHASE BARRIER**  
For 140U-M/Q Breaker  
Cat. No. - 140U-M-PB A  
Quantity - 1

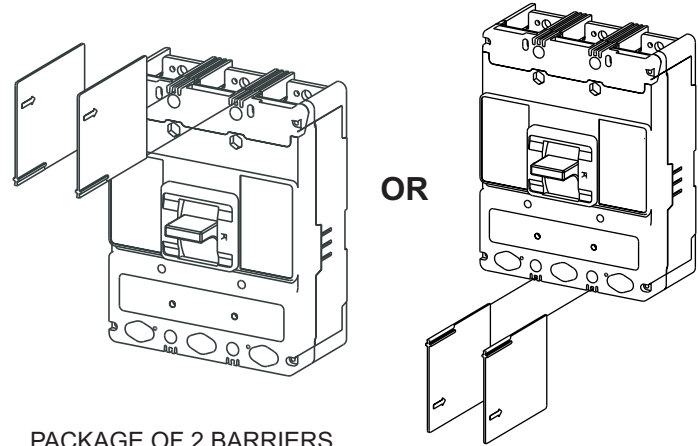

OR

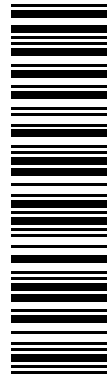

1 06 11320 84492 1

PACKAGE OF 2 BARRIERS



**INTERPHASE BARRIER**  
For 140U-M/Q Breaker  
Cat. No. - 140U-M-PB A  
Quantity - 1

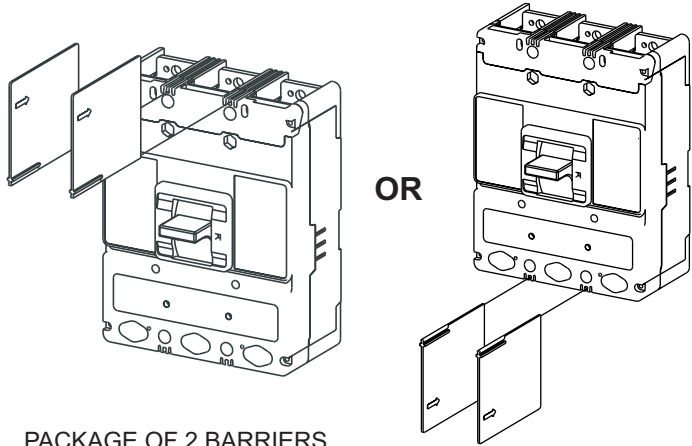

OR



1 06 11320 84492 1

PACKAGE OF 2 BARRIERS



**INTERPHASE BARRIER**  
For 140U-M/Q Breaker  
Cat. No. - 140U-M-PB A  
Quantity - 1

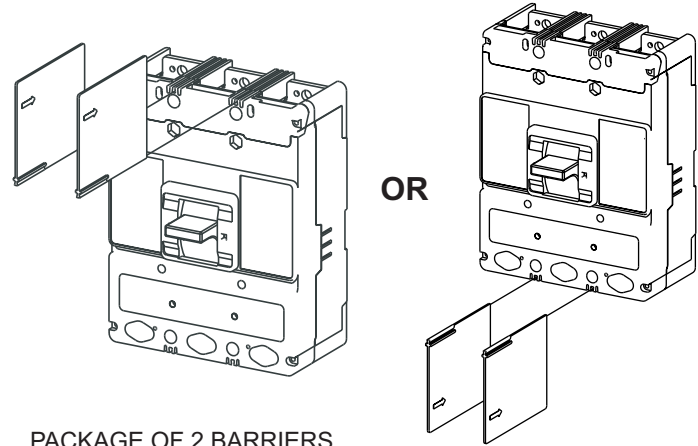

OR



1 06 11320 84492 1

PACKAGE OF 2 BARRIERS