

# Instructions for Type LT and MT Thermal-Magnetic 2-, 3-, and 4-Pole Trip Units Installation and Operation with L-Frame and MDL-Frame Series C Circuit Breakers

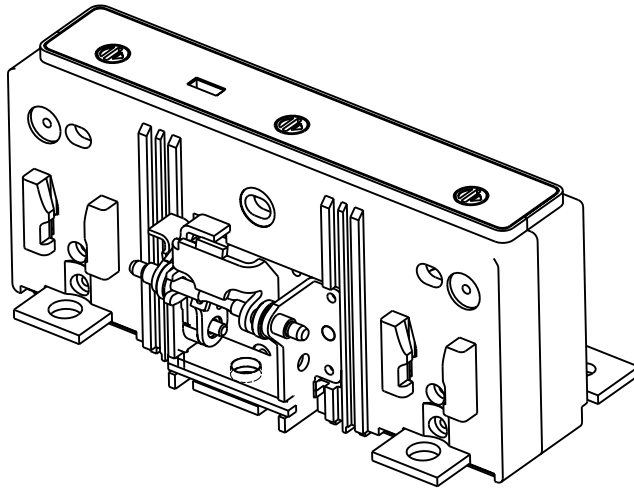

## Contents

Description	Page
1. Introduction .....	2
2. Installation .....	3



*Powering Business Worldwide*



## WARNING

**DO NOT ATTEMPT TO INSTALL OR PERFORM MAINTENANCE ON EQUIPMENT WHILE ITS IS ENERGIZED. DEATH, SEVERE PERSONAL INJURY, OR SUBSTANTIAL PROPERTY DAMAGE CAN RESULT FROM CONTACT WITH ENERGIZED EQUIPMENT. ALWAYS VERIFY THAT NO VOLTAGE IS PRESENT BEFORE PROCEEDING WITH THE TASK, AND ALWAYS FOLLOW GENERALLY ACCEPTED SAFETY PROCEDURES.**

**EATON IS NOT LIABLE FOR THE MISAPPLICATION OR MISINSTALLATION OF ITS PRODUCTS.**

The User is cautioned to observe all recommendations, warnings, and cautions relating to the safety of personnel and equipment as well as all general and local health and safety laws, codes, and procedures.

The recommendations and information contained herein are based on Eaton experience and judgement, but should not be considered to be all-inclusive or covering every application or circumstance which may arise. If any questions arise, contact Eaton for further information or instructions.

## 1. INTRODUCTION

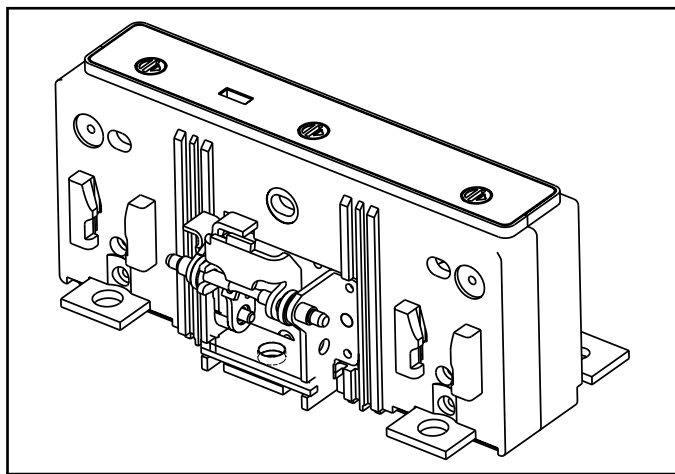

Fig. 1-1 L-Frame and MDL-Frame Series C Circuit Breaker Thermal-Magnetic Trip Unit Type LT.

## General Information

Trip units for L-frame and MDL-frame Series C circuit breakers (Fig. 1-1) are available in two types: Type LT or MT with thermal-magnetic trip functions, described in this instruction leaflet or Type LES electronic (Seltronic) trip functions, covered in Instruction Leaflets 29C608 and 29C610. Trip units are listed in accordance with Underwriters' Laboratories, Inc. Standard UL489 and satisfy the applicable requirements of the International Electrotechnical Commission Recommendations for molded case circuit breakers.

The trip unit includes either a fixed or an adjustable thermal element for inverse time delay on overload and an adjustable magnetic element for protection against short circuits. In open air at 40°C (104°F), the trip unit continuously carries a current ( $I_n$ ) equal to the ampere rating marked on the trip unit nameplate without exceeding a 50°C (122°F) rise at the terminals. The National Electrical Code (USA) requirements state that enclosed overcurrent devices may protective be loaded to a maximum of 80% of the open air rating ( $I_n$ ).

The trip unit cover is factory sealed to prevent tampering with the calibration. Tables 1-1 and 1-2 list catalog numbers and electrical data for trip units.

**Thermal Trip:** The thermal element trips the circuit breaker within 2 hours for an overload of 135 percent and trips in less time for higher overloads. For all currents in excess of the magnetic setting, the tripping action is instantaneous. In the overload trip region (up to  $6 \times I_n$ ), the trip current times are the same for AC or DC.

**Adjustable Thermal:** Trip units having an adjustable thermal element are adjusted within the range shown in Table 1-2 with a single adjusting button (see Fig. 2-3).

**Magnetic Trip:** The magnetic trip on each pole may be adjusted by turning the adjustment button with a screwdriver (see Fig. 2-3). In the magnetic trip region (above  $6 \times I_n$ ), the trip current levels can be up to approximately 40% higher for DC than for AC, depending on the rating.

**Note:** Trip units are calibrated at 40°C (104°F), 50/60 HZ and DC as noted. Consult Eaton for derating at other frequencies and ambient conditions.

**Four-Pole Trip Unit:** On UL listed four-pole trip units for use in LD, HLD, and LDC Frames the far right pole of a four-pole circuit breaker is for neutral connection only. There is no overcurrent protection in this pole (see Fig. 1-2). On the four-pole trips units for use in LW, HLW and LWC Frames the far left pole is for neutral connection only. Two versions are available, one type with 60% of  $I_n$  protection and one type with no overcurrent protection. See tables 1-1 and 1-2.

**Internal Accessories:** The following types of circuit breaker internal accessories, which mount on the Type LT and MT trip units, are available for use. The number of the instruction leaflet covering the installation of the accessory is shown.

- Alarm (Signal)/Lockout (ASL) Switch.....I.L. 29C183
- Auxiliary Switch .....I.L. 29C123
- Shunt Trip.....I.L. 29C146
- Low Energy Shunt Trip.....I.L. 29C147
- Undervoltage Release Mechanism  
(Handle Reset) .....I.L. 29C170

For further information on the L-Frame Series C circuit breaker, refer to I.L. 29C105 and Selection Data 29-120L. For the MDL-Frame, refer to I.L. 29C111.

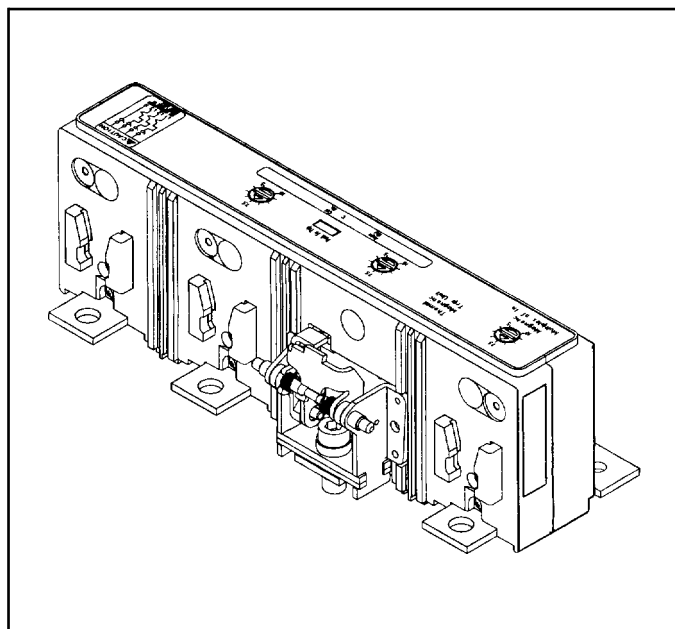

Fig. 1-2 Four-Pole LT Trip Unit with Unprotected Neutral.

## 2. INSTALLATION

There are two major differences between LT trip units and MT trip units. The MT trip units have metal tabs that prevent them from being seated into the slots in the side-plates of the LD, HLD and LDC frames as described in Sec. 2-4. Also, the MT trip unit conductors have angles on the load end, which fit within the shapes machined in the load conductors of the MDL frame. Conversely, the LT trip units will not seat into an MDL or HMDL frame. There are projections in the base mold of the MDL which interfere with the bracket of the LT trip units and the conductors will not fit within the contours of the MDL load conductor.

The installation procedure consists of inspecting and installing the trip unit. To install the trip unit, perform the following steps.

**Note: If required, internal accessory installation should be done before the circuit breaker is mounted and connected. Refer to individual accessory instruction leaflets.**

2-1. Make sure that the trip unit is suitable for the intended installation by comparing nameplate information with the existing equipment ratings and system requirements. Make sure that you are installing the correct type of trip unit, LT or MT, in the correct type of frame. Inspect the trip unit for completeness and check for damage before installing it in the circuit breaker frame.

**Note: Trip unit center retaining screw is captive in the trip unit mechanism pole bracket; the outer pole screws are supplied with the breaker frame. In the MDL-frame, the load-end trip unit mounting screws are supplied with the frame.**

2-2. Remove circuit breaker pan-head cover screws and covers.

2-3. Remove trip unit outer screws and red plastic washers from the breaker frame. Discard red plastic washers. For an MDL-frame, remove the load-end trip unit mounting screws from the frame.

**Note: The trip unit outer screws may be placed in the trip unit conductor holes at this time. If preferred, a hexagonal-head wrench may be used to position the screws when the trip unit is in the base.**

2-4. Position trip unit in base. Make sure latch bracket pin is properly seated in slots in side plates (see Fig. 2-1). If necessary, push circuit breaker handle towards the closed position to help seat trip unit.



**CAUTION**

**DO NOT EXCEED SPECIFIED TORQUE. EXCESSIVE TORQUING WILL SHEAR SCREWS.**

**FAILURE TO APPLY THE REQUIRED TORQUE MAY LEAD TO EXCESSIVE HEATING AND CAUSE NUISANCE TRIPPING OF THE CIRCUIT BREAKER.**

- 2-5. Screw in and tighten the trip unit retaining screws in each pole (mechanism pole first). Torque the line-end screws to 10-12 lb ft (13.56-16.27 Nm) (see Fig. 2-1). For the MDL-frame, torque the load-end screws to 6-8 lb ft (8.14-10.85 Nm) (see Fig. 2-2).
- 2-6. Install accessory(ies), if required. For poles where accessories are not required, install protective barriers supplied with trip unit in accessory retaining slots.
- 2-7. Make sure interphase barriers are in slots in the base of the circuit breaker.
- 2-8. Make sure that opening in sliding handle barrier (captive in cover) is aligned with circuit breaker handle.

**Note: Circuit breaker cover can be installed or removed only if the circuit breaker is in the “TRIPPED” or “OFF” position.**

- 2-9. Install the circuit breaker main cover and terminal cover on the LD-frame. Install the main cover and both terminal covers on the MDL-frame. Secure with the original screws and torque them to 20-22 lb in (2.26-2.49 Nm) (see Fig. 2-2).
- 2-10. Reset circuit breaker by moving handle to the reset position. Move handle to the ON position. Circuit breaker should remain ON.
- 2-11. Press PUSH-TO-TRIP button with a small screwdriver to check manual tripping of the circuit breaker (see Fig. 2-3).

**Trip Unit Magnetic Adjustment**

The magnetic element of each pole of the trip unit can be adjusted by rotating the adjustment buttons on the front face of the trip unit with a screwdriver. The buttons have several settings as indicated on the nameplate with val-

ues in multiples of the trip unit ampere rating ( $I_n$ ) as shown in Fig. 2-3.

**Note: Button must be set at detents and not at intermediate positions.**

To adjust the setting, rotate each button until arrow on button points to desired setting.

2-12. Adjust magnetic pick-up settings as required (see Fig. 2-3).

**Trip Unit Thermal Adjustment**

In some trip unit types, the thermal rating ( $I_n$ ) of the trip unit can be adjusted by a single button (see Fig. 2-4) within the ranges indicated in Table 1-2.



**CAUTION**

**TO PREVENT POSSIBLE INTERNAL DAMAGE TO THE TRIP UNIT, THE CIRCUIT BREAKER MUST BE TRIPPED PRIOR TO CHANGING THE THERMAL ADJUSTMENT.**

2-13. Adjust thermal setting as required (see Fig. 2-4) by rotating the thermal adjustment button until the arrow on the button points to the desired setting.

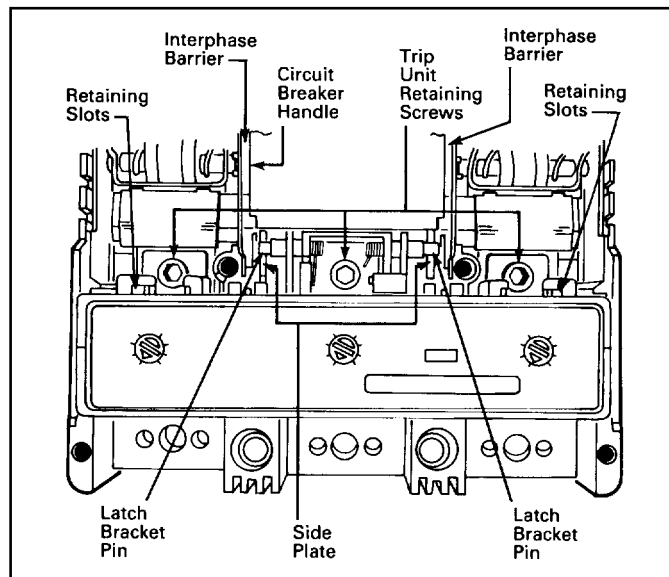

Fig. 2-1 Trip Unit Installed in an LD Frame.

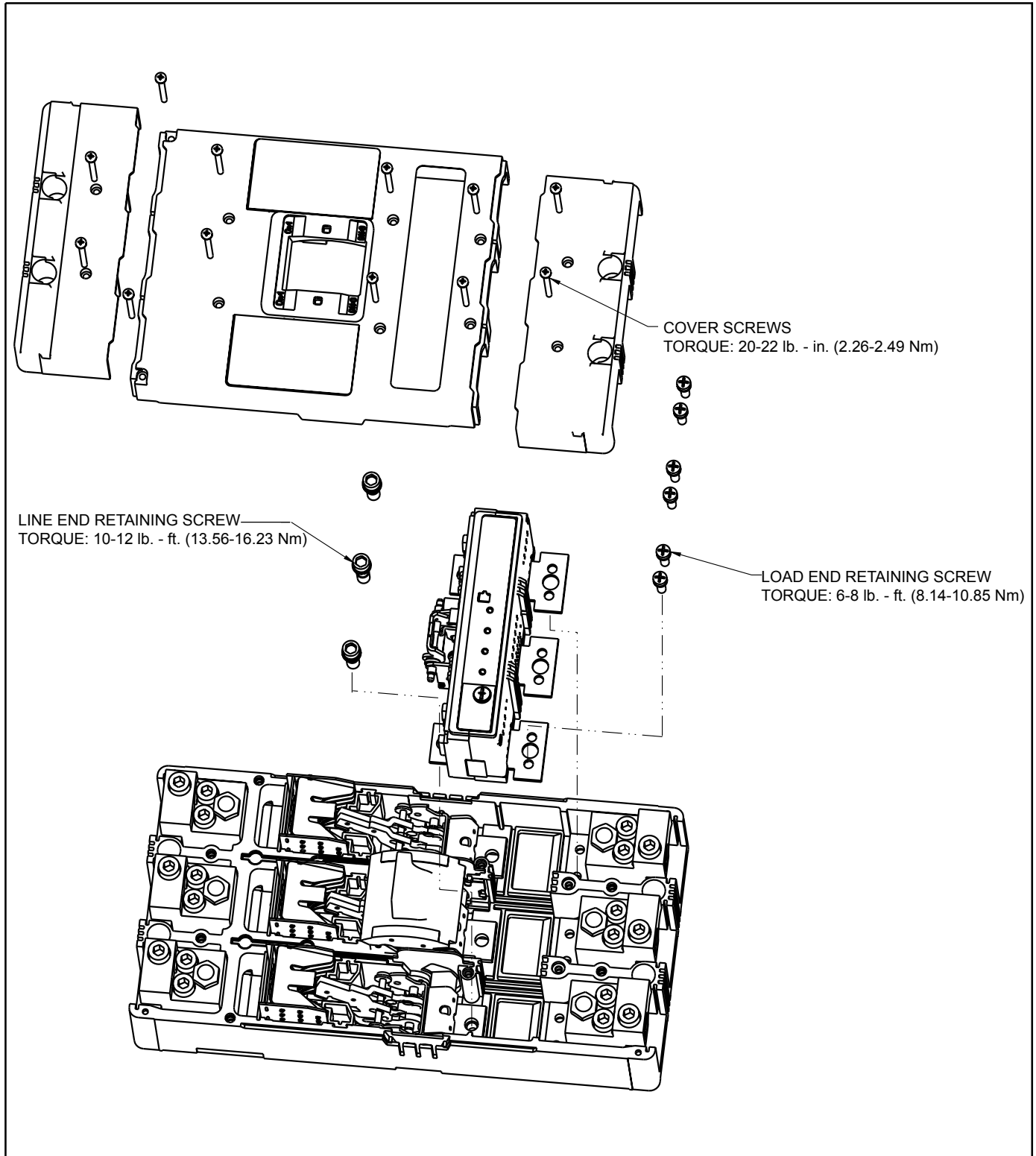

Fig. 2-2 Trip Unit and Covers Installation in an MDL Frame.

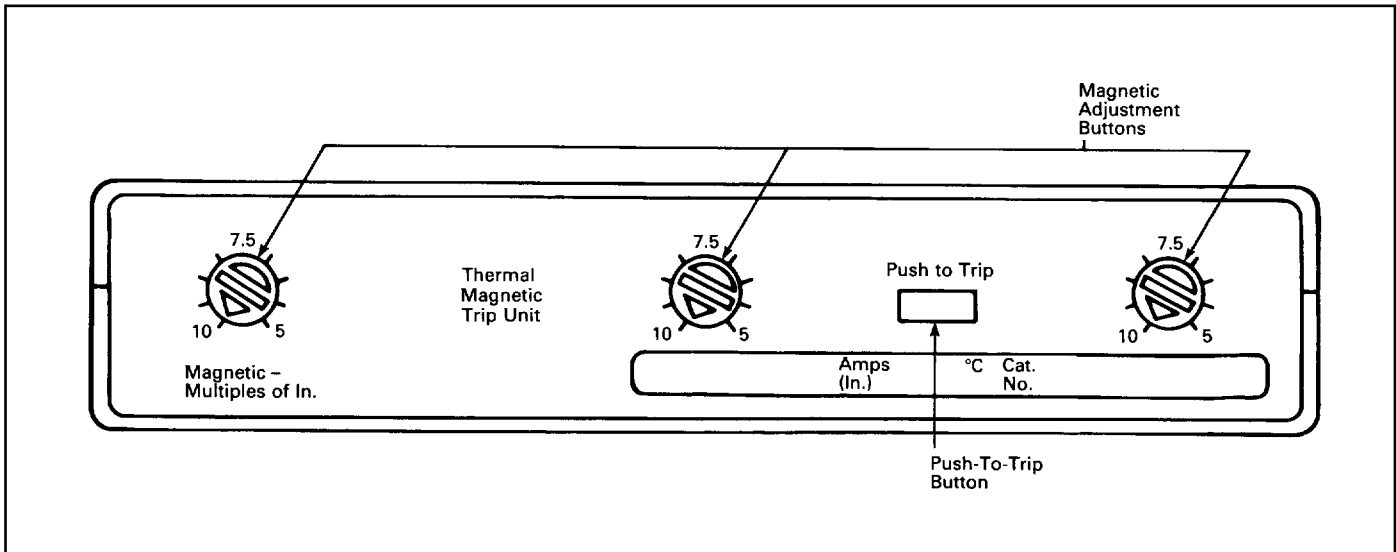

Fig. 2-3 Trip Unit Magnetic Adjustment Buttons.

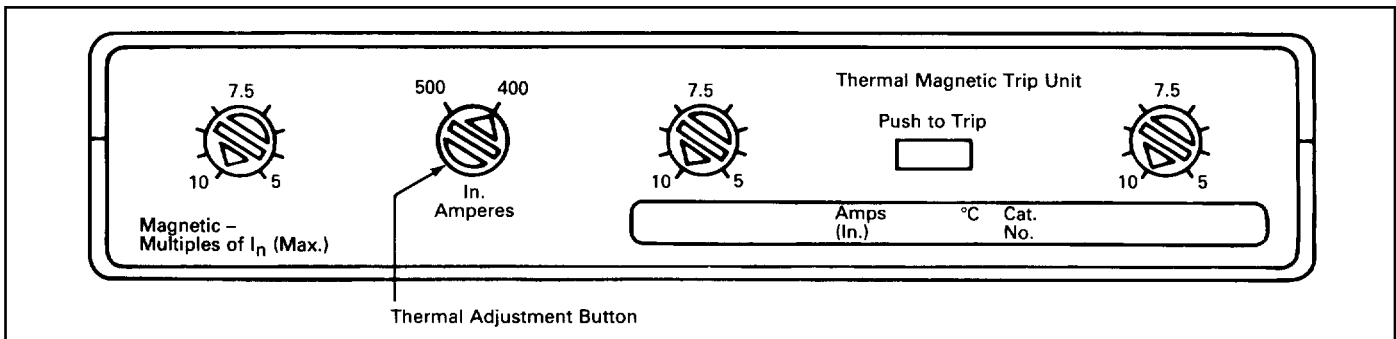

Fig. 2-4 Trip Unit Thermal Adjustment Button.

Table 1-1. LD, HLD, and LDC Trip Unit Catalog Numbers and Electrical Data - Fixed Thermal

Catalog No. 2-Pole	Catalog No. 3-Pole	Catalog No. 4-Pole ② ⑥	Continuous Ampere Rating ( $I_n$ ) 40°C	Magnetic Trip Range Amperes ①
LT2300T	LT3300T	LT4300T	300	1500-3000
LT2350T	LT3350T	LT4350T	350	1750-3500
LT2400T	LT3400T	LT4400T	400	2000-4000
LT2450T	LT3450T	LT4450T	450	2250-4500
LT2500T	LT3500T	LT4500T	500	2500-5000
LT2600T	LT3600T	LT4600T	600	3000-6000

- ① Nameplate is marked in multiples of  $I_n$ .
- ② Neutral on the right.

**Table 1-2. MDL and HMDL Trip Unit Catalog Numbers and Electrical Data.**

Catalog Number 2-Pole	Catalog Number 3-Pole	Continuous Ampere Rating $I_n$ @ 40°C	Magnetic Trip Range Amperes ④
MT2300T	MT3300T	300	1500-3000
MT2350T	MT3350T	350	1750-3599
MT2400T	MT3400T	400	2000-4000
MT2450T	MT3450T	450	2250-4500
MT2500T	MT3500T	500	2500-5000
MT2600T	MT3600T	600	3000-6000
MT2700T	MT3700T	700	2800-5600
MT2800T	MT3800T	800	3200-6400

**Table 1-3. LW, HLW, and LWC Trip Unit Catalog Numbers and Electrical Data ③ Fixed and Adjustable Thermal.**

Catalog No. 3-Pole	Continuous Ampere Rating ( $I_n$ ) 40°C	Magnetic Trip Range Amperes ④
LTF3315T	315	1575-3150
LTF3400T	400	2000-4000
LTF3500T	500	2500-5000
LTF3630T	630	3150-6300
LT3315TA	315-250	1575-3150
LT3400TA	400-315	2000-4000
LT3500TA	500-400	2500-5000
LT3630TA	630-500	3150-6300
Catalog No. 4-Pole ⑤	Continuous Ampere Rating ( $I_n$ ) 40°C	Magnetic Trip Range Amperes ④
LT4315TA ⑥	315-250	1575-3150
LT4400TA	400-315	2000-4000
LT4500TA	500-400	2500-5000
LT4630TA	630-500	3150-6300
LT4315TAE ⑦	315-250	1575-3150
LT4400TAE	400-315	2000-4000
LT4500TAE	500-400	2500-5000
LT34630TAE	630-500	3150-6300

③ Not UL listed.

④ Nameplate is marked in multiples of  $I_n$  (Max.).

⑤ Neutral on the left.

⑥ No overcurrent protection in the neutral pole.

⑦ 60% of  $I_n$  protection in the neutral pole.

The instructions for installation, testing, maintenance, or repair herein are provided for the use of the product in general commercial applications and may not be appropriate for use in nuclear applications. Additional instructions may be available upon specific request to replace, amend, or supplement these instructions to qualify them for use with the product in safety-related applications in a nuclear facility.

This Instruction Booklet is published solely for information purposes and should not be considered all-inclusive. If further information is required, you should consult an authorized Eaton sales representative.

The sale of the product shown in this literature is subject to the terms and conditions outlined in appropriate Eaton selling policies or other contractual agreement between the parties. This literature is not intended to and does not enlarge or add to any such contract. The sole source governing the rights and remedies of any purchaser of this equipment is the contract between the purchaser and Eaton.

**NO WARRANTIES, EXPRESSED OR IMPLIED, INCLUDING WARRANTIES OF FITNESS FOR A PARTICULAR PURPOSE OR MERCHANTABILITY, OR WARRANTIES ARISING FROM COURSE OF DEALING OR USAGE OF TRADE, ARE MADE REGARDING THE INFORMATION, RECOMMENDATIONS, AND DESCRIPTIONS CONTAINED HEREIN.**

In no event will Eaton be responsible to the purchaser or user in contract, in tort (including negligence), strict liability or otherwise for any special, indirect, incidental or consequential damage or loss whatsoever, including but not limited to damage or loss of use of equipment, plant or power system, cost of capital, loss of power, additional expenses in the use of existing power facilities, or claims against the purchaser or user by its customers resulting from the use of the information, recommendations and description contained herein.

**Eaton Corporation**  
Electrical Sector  
1111 Superior Ave.  
Cleveland, OH 44114  
United States  
877-ETN-CARE (877-386-2273)  
Eaton.com

© 2011 Eaton Corporation  
All Rights Reserved  
Printed in USA  
Publication No. IL29C607J / TBG000775  
Part No. 6633C02H10  
December 2011