



Installation Instructions for the Walking Beam Interlock K-Frame Series C Circuit Breakers and Molded Case Switches



WARNING

DO NOT ATTEMPT TO INSTALL OR PERFORM MAINTENANCE ON EQUIPMENT WHILE IT IS ENERGIZED. DEATH, SEVERE PERSONAL INJURY, OR SUBSTANTIAL PROPERTY DAMAGE CAN RESULT FROM CONTACT WITH ENERGIZED EQUIPMENT. ALWAYS VERIFY THAT NO VOLTAGE IS PRESENT BEFORE PROCEEDING WITH THE TASK, AND ALWAYS FOLLOW GENERALLY ACCEPTED SAFETY PROCEDURES.

CUTLER-HAMMER IS NOT LIABLE FOR THE MISAPPLICATION OR MISINSTALLATION OF ITS PRODUCTS.

The user is cautioned to observe all recommendations, warnings, and cautions relating to the safety of personnel and equipment, as well as, all general and local health and safety laws, codes, and procedures.

The recommendations and information contained herein are based on Cutler-Hammer experience and judgement, but should not be considered to be all-inclusive or covering every application or circumstance which may arise. If any questions arise, contact Cutler-Hammer for further information or instructions.

1. INTRODUCTION

General Information

The walking beam interlock (Fig. 1-1) provides mechanical interlocking between two adjacent circuit breakers of the same pole configuration to prevent both circuit breakers from being switched on at the same time. The walking beam interlock assembly is bolted to the rear of a customer-supplied mounting panel. The circuit breakers are then secured to the mounting panel. Plungers are inserted through access holes in the mounting panel and base of each circuit breaker. The plungers are then attached to each end of the beam assembly. Adjustment of the walking beam assembly is then necessary for the panel thickness being used. Customer-supplied mounting panels from 1/8" to one inch thick can be used with the walking beam interlock.

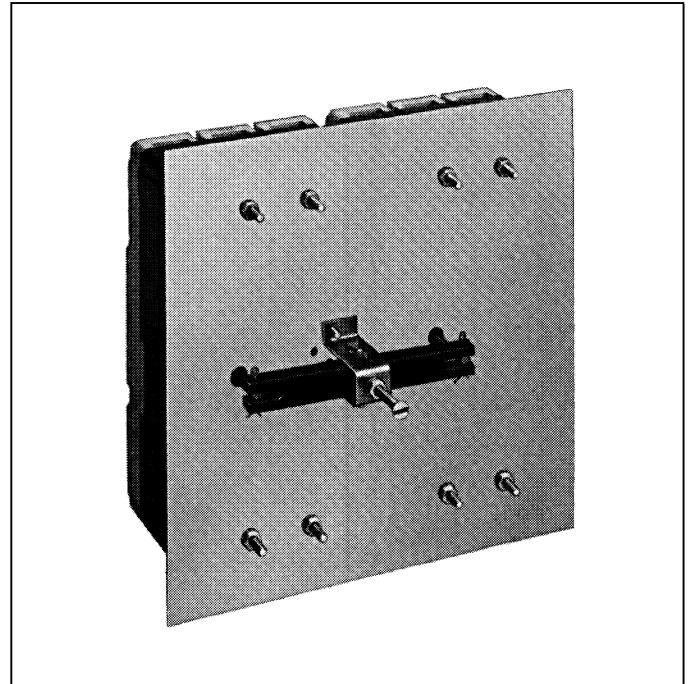

Fig. 1-1. Walking Beam Interlock Installed Between Two 3-Pole K-Frame Series C Circuit Breakers

When the walking beam interlock is used, the wiring troughs in the back of each circuit breaker base are blocked by the plungers and cannot be used for opposite side-exiting pigtail leads.

The walking beam interlock is UL listed for field installation per UL File E64983.

Note: Factory modified circuit breakers must be ordered to install the walking beam interlock.

This instruction leaflet (IL) gives detailed procedures for installing the walking beam interlock.

2. INSTALLATION

The walking beam interlock must be mounted before the circuit breakers are connected to an electrical system. Installation consists of drilling mounting panel to accept circuit breakers and walking beam assembly; securing circuit breakers to mounting surface; and, installing walking beam. To install the walking beam interlock, perform the following steps:



WARNING

BEFORE ATTEMPTING ANY WORK ON CIRCUIT BREAKERS INSTALLED IN AN ELECTRICAL SYSTEM, MAKE SURE THE CIRCUIT BREAKERS ARE SWITCHED TO THE OFF POSITION AND THAT THERE IS NO VOLTAGE PRESENT WHERE WORK IS TO BE PERFORMED. SPECIAL ATTENTION SHOULD BE PAID TO REVERSE FEED APPLICATIONS TO ENSURE NO VOLTAGE IS PRESENT. THE VOLTAGES IN ENERGIZED EQUIPMENT CAN CAUSE SEVERE PERSONAL INJURY OR DEATH.

2-1. Determine thickness of customer-supplied mounting panel. From Fig. 2-1, select hole type and sizes for installing walking beam mounting bracket. For panel thicknesses from .125 to less than .500 in. use countersunk holes. For panel thicknesses from .500 up to 1.00 in. use counterbored holes.

2-2. Pre-drill circuit breaker mounting panel. Fig. 2-2 (K-frame, 2- and 3-pole), and Fig. 2-3 (K-frame 4-pole) show mounting panel hole sizes and dimensions for K-frame Series C circuit breaker configurations. Dimensions are in inches and millimeters.

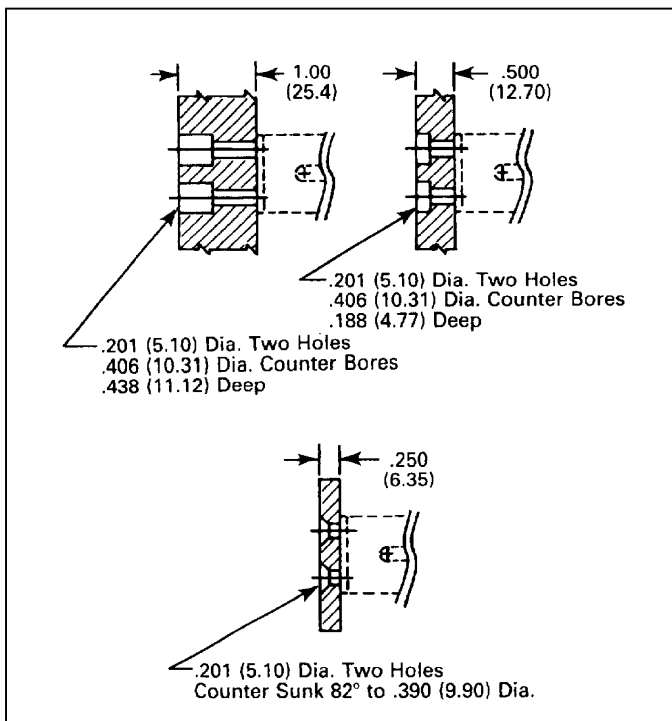

Fig. 2-1. Hole Sizes for Installing Walking Beam Mounting Bracket

2-3. Install mounting bracket to back of customer-supplied mounting panel using two screws and lock washers supplied (Fig. 2-4.).

2-4. Position micarta beam inside legs of mounting bracket. Install pivot pin through bracket and micarta beam (Fig. 2-4). Secure pivot pin in position using two small cotter pins and flat washers supplied.



CAUTION

TWO NYLON INSULATING PLUGS ARE PROVIDED IN THE WALKING BEAM INTERLOCK KIT. THE PLUGS MUST BE INSTALLED BEFORE THE CIRCUIT BREAKERS ARE MOUNTED. FAILURE TO INSTALL THE PLUGS CAN RESULT IN PHASE-TO-GROUND ARCING AND LEAD TO EQUIPMENT FAILURE AND DAMAGE.

2-5. When mounting K-frame circuit breakers to panel, insert two nylon insulating plugs in .500 inch (12.7 mm) diameter holes between mounting panel and circuit breaker (Fig. 2-5).

2-6. Mount circuit breakers to front surface of mounting panel using hardware supplied with the circuit breakers. Plunger access holes in the back of the circuit breakers should line-up with holes previously drilled in panel.

2-7. Insert ends of plungers through the mounting panel, and into the circuit breakers (Fig. 2-5).

2-8. With both the circuit breakers in the OFF position, attach the plungers to the micarta beam using the longer cotter pins supplied (Fig. 2-6). Use outer holes in micarta beam for 2- and 3-pole applications and inner holes for 4-pole application.

3. ADJUSTMENT

The walking beam interlock must be adjusted before the circuit breakers are connected to an electrical system.

3-1. Turn one breaker to the on position and the other to the off position.

3-2. Screw 2" pan head screw into threaded hole in top of the mount bracket with the nut and lockwasher supplied (Fig. 2-5).

3-3. Finger tighten the screw down on to the beam pivot pin until all rocking of the beam is eliminated. **DO NOT** over tighten.

3-4. Lock the pan head screw in position by tightening the nut against the mounting bracket. Do not allow the screw to turn while tightening the nut. (Fig. 2-6).

3-5. Carry out a functional check as follows:

- a. Make sure that both circuit breakers cannot be switched to the ON position at the same time.
- b. Open one circuit breaker. Be sure the other will close.
- c. Reverse the open and close operation.

3-6. Connect circuit breakers as required.

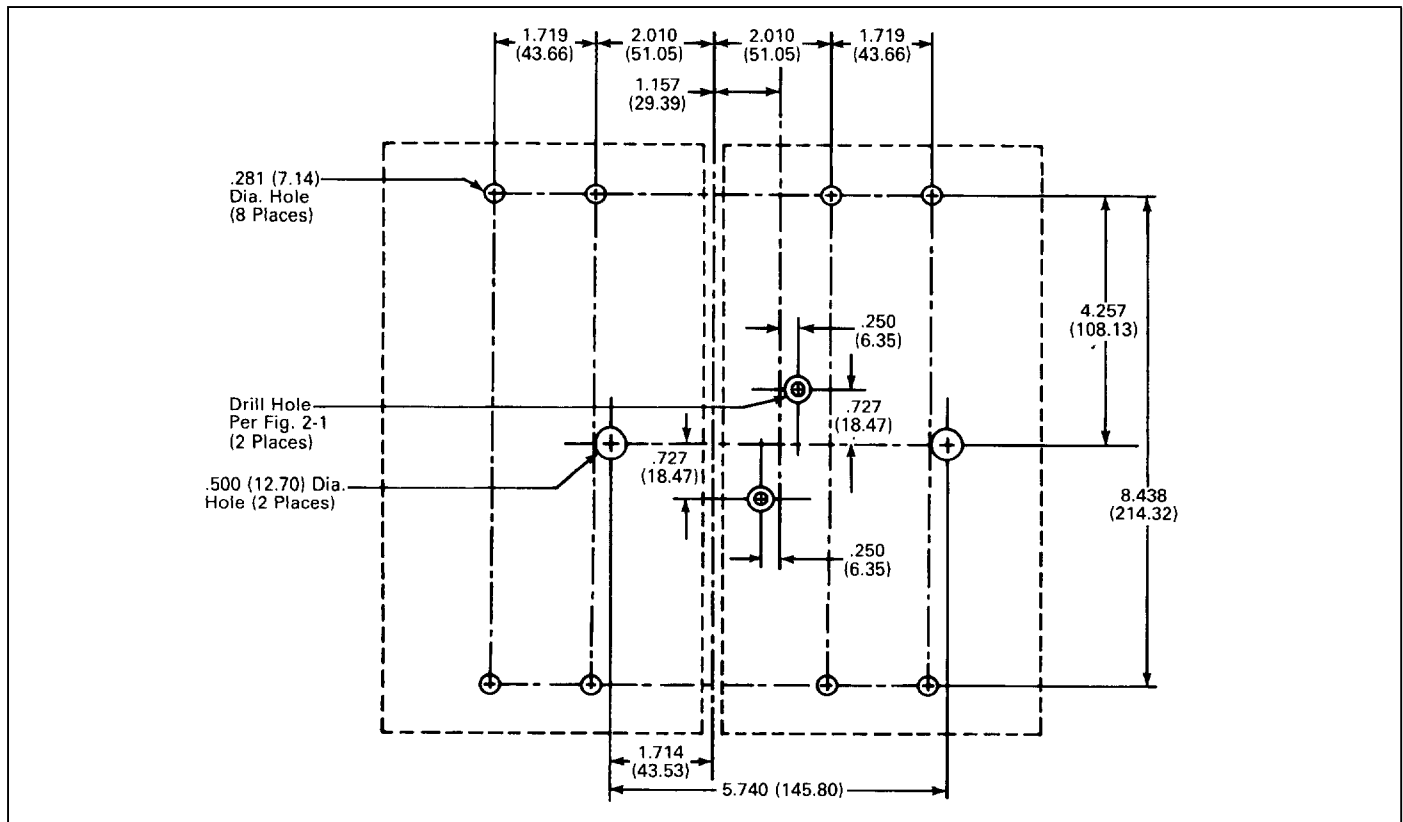

Fig. 2-2. K-Frame 2- and 3-Pole Circuit Breaker Mounting Panel Hole Sizes and Dimensions

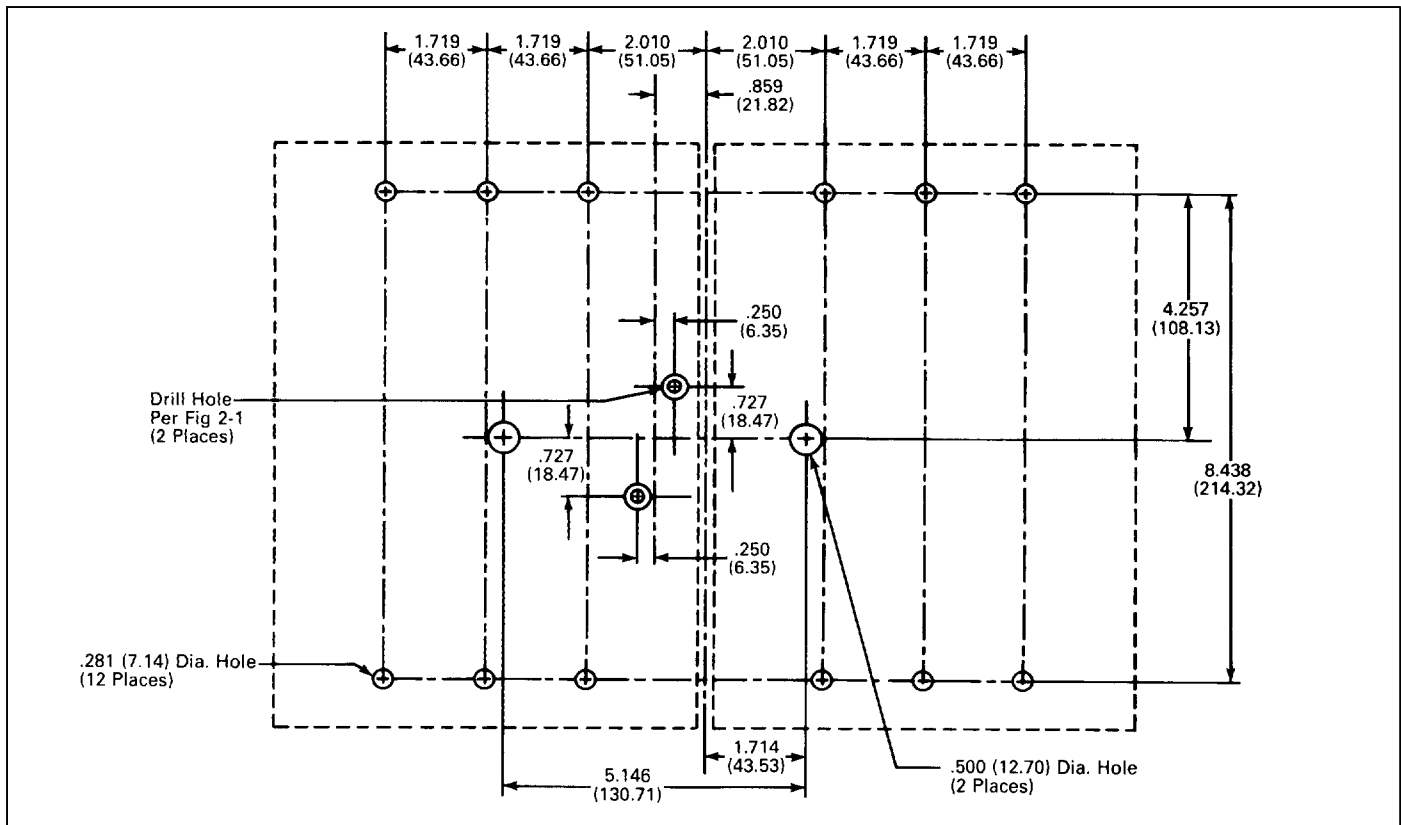

Fig. 2-3. K-Frame 4-Pole Circuit Breaker Mounting Panel Hole Sizes and Dimensions

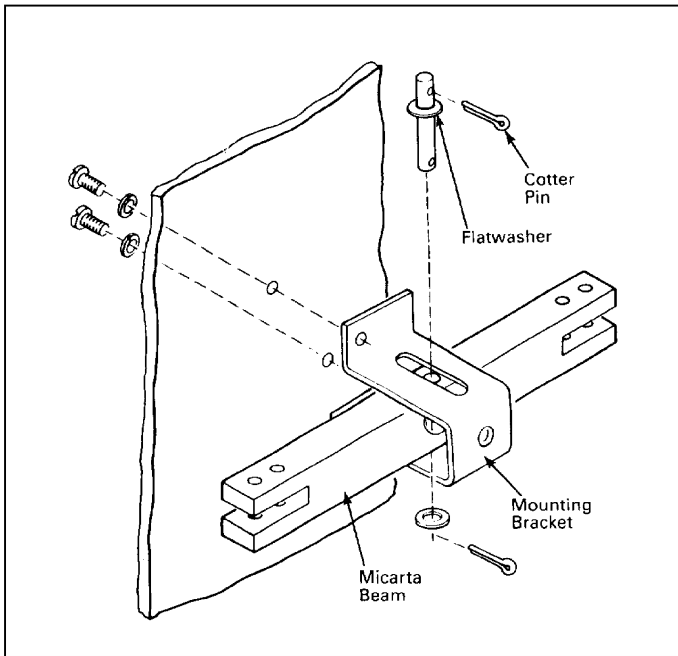

Fig. 2-4. Assembly and Installation of Mounting Bracket and Micarta Beam

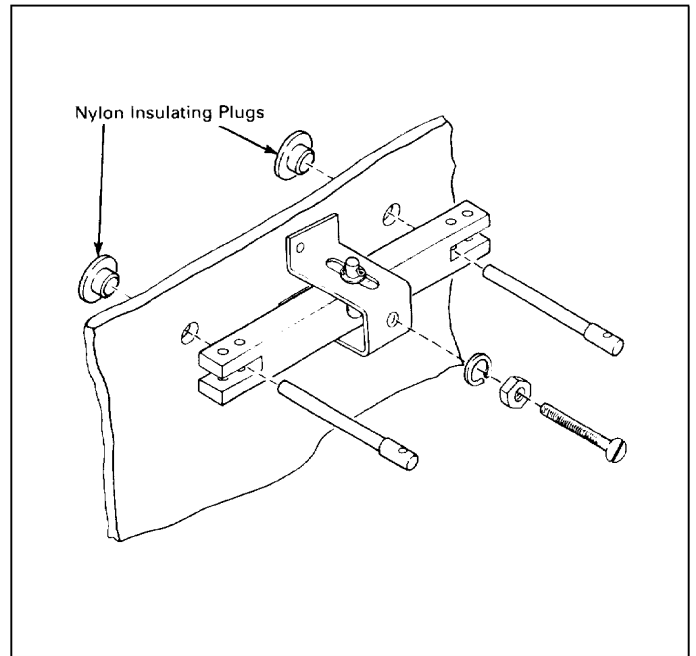

Fig. 2-5. Plungers Positioned through Backplate

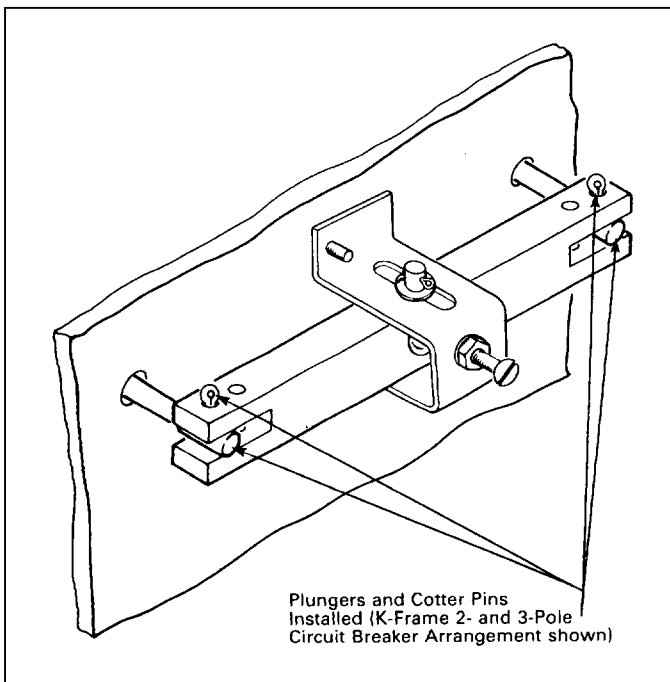

Fig. 2-6. Walking Beam Final Assembly

Cutler-Hammer

Pittsburgh, Pennsylvania U.S.A.

Style No. 6632C94H04 Effective December 1997
Printed in U.S.A./CCI

